



XF series expansion module

User's manual

Wuxi Xinje Electric Co., Ltd.

Reference number:PF 02 20260516 1.8

	Safety Notes	
	Catalogue	
	Document Guide	1
	Term	2
	Product System Configuration	3
XF series expansion module user's manual	Power Module Unit XF-P35-E	4
	XF-EP24 Repeater Power Module	5
	Digital Module Unit	6
	Analog Module Unit	7
	Serial Communication Module Unit	8
	Temperature Module Unit	9
	High Speed Counting Module Unit	10
	Pulse Output Module Unit	11
	Frequently Asked Questions	12
	Manual Update Log	

Basic Description

- ◆ Thank you for purchasing the XJIE XF series programmable controllers and XF-IO products.
- ◆ This manual provides users with essential information on precautions, specifications, and features when operating the XF-IO unit.
- ◆ Before use, thoroughly review this manual and related manuals to fully understand the functions and performance of the XF-IO series expansion modules, ensuring proper operation of this product.
- ◆ For information on software and programming, please refer to the relevant manuals.
- ◆ Please deliver this manual to the end user.

User Notice

- ◆ Only operators with basic electrical knowledge are authorized to perform wiring and related operations on the product. If any unclear usage occurs, please Consult our technical staff.
- ◆ The examples in manuals and other technical documents are provided for users' reference only and do not guarantee specific actions.
- ◆ When using this product with other products, ensure it meets the relevant specifications and principles.
- ◆ When using this product, verify that it meets the requirements and is safe.
- ◆ Please configure backup and safety functions to prevent machine malfunctions or losses caused by this product's failure.

Statement of responsibility

- ◆ The contents of the manual have been carefully checked, but errors are inevitable, and we cannot guarantee complete consistency.
- ◆ We will review the manual regularly and make corrections in future versions.
- ◆ The contents described in the manual are subject to change without further notice.

Contact way

If you have any questions about using this product, please contact the purchasing agent or office, or directly reach out to xinje Company.

- ◆ General: 0510-85134136
- ◆ Hotline: 400-885-0136
- ◆ Fax: 0510-85111290
- ◆ Website: www.xinje.com
- ◆ Address: No.816, West Jianzhu Road, Binhu District, Wuxi City, Jiangsu Province

Wuxi Xinje Electric Co., Ltd. Copyright

No reproduction, distribution, or use of this material or its contents is permitted without explicit written permission. Violators shall be liable for any resulting damages. All rights, including those related to patents and registrations of utility modules or designs, are reserved.

September 2023

Safety Notes

(Read before use)

The safety precautions for potential issues during product use are outlined, categorized as 'Caution' or 'Danger'. For any remaining matters, please follow the basic electrical operating procedures.



Attention

Improper use may result in danger, with the possibility of moderate injury or minor injury, and may cause property damage.



Danger

When used incorrectly, it may cause danger, resulting in personal injury or death, serious harm, and possibly Critical property damage.

■ Confirm when receiving the product



Attention

1. Do not install controllers that are damaged, missing parts, or do not meet the required model.
There is a risk of injury.

■ System design of product



Danger

1. Design a safety circuit outside the controller to ensure the system remains safe even if the controller malfunctions.
There is a risk of causing misoperation and failure.



Attention

1. Do not bundle control wiring with power wiring; maintain a 10cm separation between them.
It may cause misoperation and product damage.

■ Product installation



Danger

1. Before installing the controller, make sure to disconnect all external power sources.
There is a risk of electric shock.



Attention

1. Install and use this product under the environmental conditions specified in the general specifications of the manual.
Do not use in damp, high temperature, dust, smoke, conductive dust, corrosive gas, flammable gas, and vibration, impact.
It may cause electric shock, fire, misoperation, product damage, etc.
2. Do not touch the conductive parts of the product directly.
It may cause misoperation and failure.
3. Secure this product using DIN46277 rails and install it on a flat surface.
Incorrect installation may cause malfunctions or product damage.
4. When processing screw holes, do not let the cutting powder and wire fragments fall into the product shell.
It may cause misoperation and failure.
5. When connecting expansion modules with extension cables, ensure the connections are secure and the contacts are in good condition.
It may lead to poor communication and misoperation.
6. Always disconnect power before connecting peripheral devices, expansion devices, batteries, or other equipment.
It may cause misoperation and failure.

■ Product wiring



Danger

1. Before wiring the controller, make sure to disconnect all external power sources.
There is a risk of electric shock.
2. Connect the AC or DC power supply correctly to the controller's dedicated power terminal.
Incorrect power supply connection may burn out the controller.
3. Before powering on or running the controller, make sure to cover the terminal block.
There is a risk of electric shock.



Attention

1. Do not connect external 24V power to the 24V/0V terminals of the controller or expansion module.
It may cause damage to the product.
2. Use 2mm² wire to connect the controller and expansion devices to the third grounding terminal, and avoid sharing the common ground with the high-voltage system.
It may cause failure and product damage.

**Attention**

3. Do not connect external wires to the open terminals.
It may cause misoperation and product damage.
4. During screw hole machining, prevent cutting powder and wire fragments from entering the product casing.
It may cause misoperation or failure.
5. When connecting terminals with wires, ensure they are securely tightened and avoid letting the conductive parts touch other wires or terminals.
It may cause misoperation and product damage.

■ Operation and maintenance of the product**Danger**

1. Do not touch the terminals after powering on the controller.
2.
There is a risk of electric shock.
3. Do not perform terminal wiring or disconnection while the device is powered on.
There is a risk of electric shock.
4. Before modifying the program in the controller, make sure to stop it first.
It may cause misoperation.

**Attention**

1. Do not disassemble or assemble this product without authorization.
It may cause damage to the product.
2. Please plug and unplug the cable when the power is off.
It may cause damage to the cable and cause misoperation.
3. Do not connect external wires to the open terminals.
It may cause misoperation and product damage.
4. Before removing expansion devices, peripheral devices, or batteries, please first power off the device.
It may cause misoperation and failure.
5. When the product is discarded, it should be treated as industrial waste.
6. Before installing the equipment, make sure to turn off the power supply. If the power is still on, the equipment may malfunction or be damaged. Do not turn off the CPU unit or intermediate power supply when disassembling the XF-I/O unit.
It may cause failure and product damage.
7. Avoid applying tape or labels to the device's sides or gold fingers. These materials may interfere with the vertical sliding installation of module units, and adhesive residues or debris from labels/tapes could stick to the pins of the XF-I/O bus connector.
It may cause misoperation or failure.
8. Avoid touching the XF-I/O bus connectors on the device, as sweat and dust may accumulate on the connectors or gold fingers.
This may cause a failure.



Attention

NG

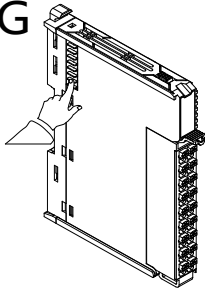

NG

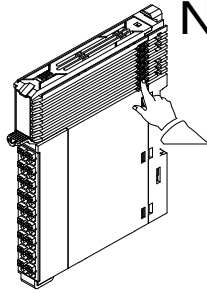

9. Do not write on the device with ink in the area shown in the image.
This may cause a failure.

Catalogue

Safety Notes	i
Catalogue	v
1. Document Guide	1
1.1 Related manuals	1
1.2 Methods for Reading the Manual	1
2. Terms	2
3. Product System Configuration	3
3.1 General Configuration	3
3.2 Key Points	4
4. Power module unit XF-P35-E	5
4.1 Product Overview	5
4.2 Naming Rules	5
4.3 Module View	6
4.4 General Specifications	6
4.5 Technical Specifications	7
4.6 Installation & Wiring	8
4.6.1 Exterior dimensions diagram	8
4.6.2 Installation Method	8
4.6.3 Installation Environment	9
5. Relay power module XF-EP24	10
5.1 Product Overview	10
5.2 Naming Rules	10
5.3 Module View	11
5.4 General Specifications	12
5.5 Technical Specifications	13
5.6 Installation & Wiring	13
5.6.1 Exterior dimensions diagram	13
5.6.2 Terminal Definition & Wiring	14
5.6.3 Installation Method	15
5.6.4 Installation Environment	15
5.7 Parameters and Mapping Addresses	16
6. Digital Quantity Module Unit	17
6.1 Naming Rules	17
6.2 Digital Input Unit XF-E16X	18

6.2.1 Product Overview	18
6.2.2 Module View	18
6.2.3 General Specifications	20
6.2.4 Technical Specifications	20
6.2.5 Installation & Wiring	21
6.2.6 Parameters and Mapping Addresses	26
6.2.7 Functions and Settings	28
6.3 Digital Output Unit XF-E16 (P)YT	30
6.3.1 Product Overview	30
6.3.2 Module View	30
6.3.3 General Specifications	32
6.3.4 Technical Specifications	33
6.3.5 Installation & Wiring	33
6.3.6 Parameters and Mapping Addresses	38
6.3.7 Functions and Settings	40
6.4 Digital Input/Output Hybrid Unit XF-E8NX8YT	42
6.4.1 Product Overview	42
6.4.2 Module View	42
6.4.3 General Specifications	44
6.4.4 Technical Specifications	44
6.4.5 Installation & Wiring	46
6.4.6 Parameters and Mapping Addresses	51
6.4.7 Functions and Settings	53
6.5 Digital Input Unit XF-E32X	56
6.5.1 Product Overview	56
6.5.2 Module View	56
6.5.3 General Specifications	58
6.5.4 Technical Specifications	59
6.5.5 Installation & Wiring	59
6.5.6 Parameters and Mapping Addresses	64
6.5.7 Functions and Settings	66
6.6 Digital Output Unit XF-E32YT	68
6.6.1 Product Overview	68
6.6.2 Module View	68
6.6.3 General Specifications	70
6.6.4 Technical Specifications	71
6.6.5 Installation & Wiring	71
6.6.6 Parameters and Mapping Addresses	76
6.6.7 Functions and Settings	77
6.7 Digital Input/Output Unit XF-E16X16YT	79
6.7.1 Product Overview	79
6.7.2 Module View	79
6.7.3 General Specifications	81
6.7.4 Technical Specifications	82
6.7.5 Installation & Wiring	83
6.7.6 Parameters and Mapping Addresses	88

6.7.7 Functions and Settings	90
6.8 Digital Output Unit XF-E8YR	93
6.8.1 Product Overview	93
6.8.2 Module View	93
6.8.3 General Specifications	95
6.8.4 Technical Specifications	95
6.8.5 Installation & Wiring	96
6.8.6 Parameters and Mapping Addresses	101
6.8.7 Functions and Settings	101
7. Analog Module Unit	104
7.1 Naming Rules	104
7.2 Analog Input Unit XF-E4AD	105
7.2.1 Product Overview	105
7.2.2 Module View	105
7.2.3 General Specifications	107
7.2.4 Technical Specifications	107
7.2.5 Installation & Wiring	110
7.2.6 Parameters and Mapping Addresses	115
7.2.7 Functions and Settings	124
7.3 Analog Output Unit XF-E4DA	131
7.3.1 Product Overview	131
7.3.2 Module View	131
7.3.3 General Specifications	133
7.3.4 Technical Specifications	134
7.3.5 Installation & Wiring	136
7.3.6 Parameters and Mapping Addresses	140
7.3.7 Functions and Settings	145
7.4 Analog Input current unit XF-E8AD-A	149
7.4.1 Product Overview	149
7.4.2 Module View	149
7.4.3 General Specifications	151
7.4.4 Technical Specifications	151
7.4.5 Installation & Wiring	153
7.4.6 Parameters and Mapping Addresses	158
7.4.7 Functions and Settings	164
7.5 Analog Input current unit XF-E8AD-V	170
7.5.1 Product Overview	170
7.5.2 Module View	170
7.5.3 General Specifications	172
7.5.4 Technical Specifications	173
7.5.5 Installation & Wiring	174
7.5.6 Parameters and Mapping Addresses	178
7.5.7 Functions and Settings	186
8. Serial Communication Module Unit	223
8.1 Naming Rules	223

8.2 Serial Communication Unit XF-E2COM24	224
8.2.1 Product Overview	224
8.2.2 Module View	224
8.2.3 General Specifications	226
8.2.4 Technical Specifications	227
8.2.5 Installation & Wiring	227
8.2.6 Functions and Settings	232
8.2.7 Configuration Module	235
9. Temperature module unit	244
9.1 Naming Rules	244
9.2 Ordinary Resistance Temperature Detector Temperature Acquisition Unit XF-E4RTD	245
9.2.1 Product Overview	245
9.2.2 Module View	245
9.2.3 General Specifications	247
9.2.4 Technical Specifications	247
9.2.5 Sensor Accuracy Table	248
9.2.6 Installation & Wiring	249
9.2.7 Configuration Module	253
9.2.8 Module Parameters	254
9.2.9 I/O Mapping	257
9.3 Ordinary thermocouple temperature acquisition unit XF-E4TC	259
9.3.1 Product Overview	259
9.3.2 Module View	259
9.3.3 General Specifications	261
9.3.4 Technical Specifications	261
9.3.5 Sensor Accuracy Table	263
9.3.6 Installation & Wiring	264
9.3.7 Configuration Module	269
9.3.8 Module Parameters	269
9.3.9 I/O Mapping	274
10. High-speed counting module unit	276
10.1 Naming Rules	276
10.2 High-speed counting module unit XF-E1HSC	277
10.2.1 Product Overview	277
10.2.2 Module View	277
10.2.3 General Specifications	279
10.2.4 Technical Specifications	280
10.2.5 Installation & Wiring	281
10.2.6 Configuration Module	286
10.2.7 Instruction Introduction	286
10.2.8 Functions and Settings	294
11. Pulse output module unit	305
11.1 Naming Rules	305
11.2 Pulse Output Module Unit XF-E2HSP	306

11.2.1 Product Overview	306
11.2.2 Module View	306
11.2.3 General Specifications	308
11.2.4 Technical Specifications	309
11.2.5 Installation & Wiring	310
11.2.6 Configuration Module	314
11.2.7 Functions and Settings	316
11.2.8 Application Examples	319
12. Frequently Asked Questions	327
Manual update log	328

1. Document Guide

1.1 Related manuals

1) CPU unit

Manual Name	Main Content
XSF series hardware user manual	It mainly records the hardware specifications and hardware maintenance information of XSF series CPU units.
XS Series PLCopen Standard Controller User Manual: Basic Instructions (XS Studio)	Mainly records the application of basic instructions for the XS series.
XS Series PLCopen Standard Controller User Manual: Motion Control (XS Studio)	Application of XS Series Motion Control Command

2) I/O cell

Manual Name	Main Content
XF Series Expansion Module User Manual	This document primarily documents the product specifications and maintenance guidelines for XF-series IO units.

1.2 Methods for Reading the Manual

The following Explanations the page layout and symbols in this manual.

The following is an explanation of how to read this manual, so it may differs from the actual documented content.

2. Terminology

In this manual, unless otherwise specified, the following terms will be used.

Terminology	Explanation
CPU unit	XF/XSF series CPU units
Power module nit	Protection rating compliant with DIN 40050: Provides protection against finger contact and penetration by particles larger than 12mm in diameter
IP20	Protection level compliant with DIN 40050: Provides protection against finger contact and the ingress of particles larger than 12mm in diameter.
Backplane bus	The backplane bus is a serial data bus used by various modules to communicate with each other. The backplane bus is also used to supply some of the necessary power to the modules. Each module is connected via a bus connector.

3. Product System Configuration

This chapter Explains the overall configuration, precautions during configuration, and information related to peripheral devices.

3.1 General Configuration

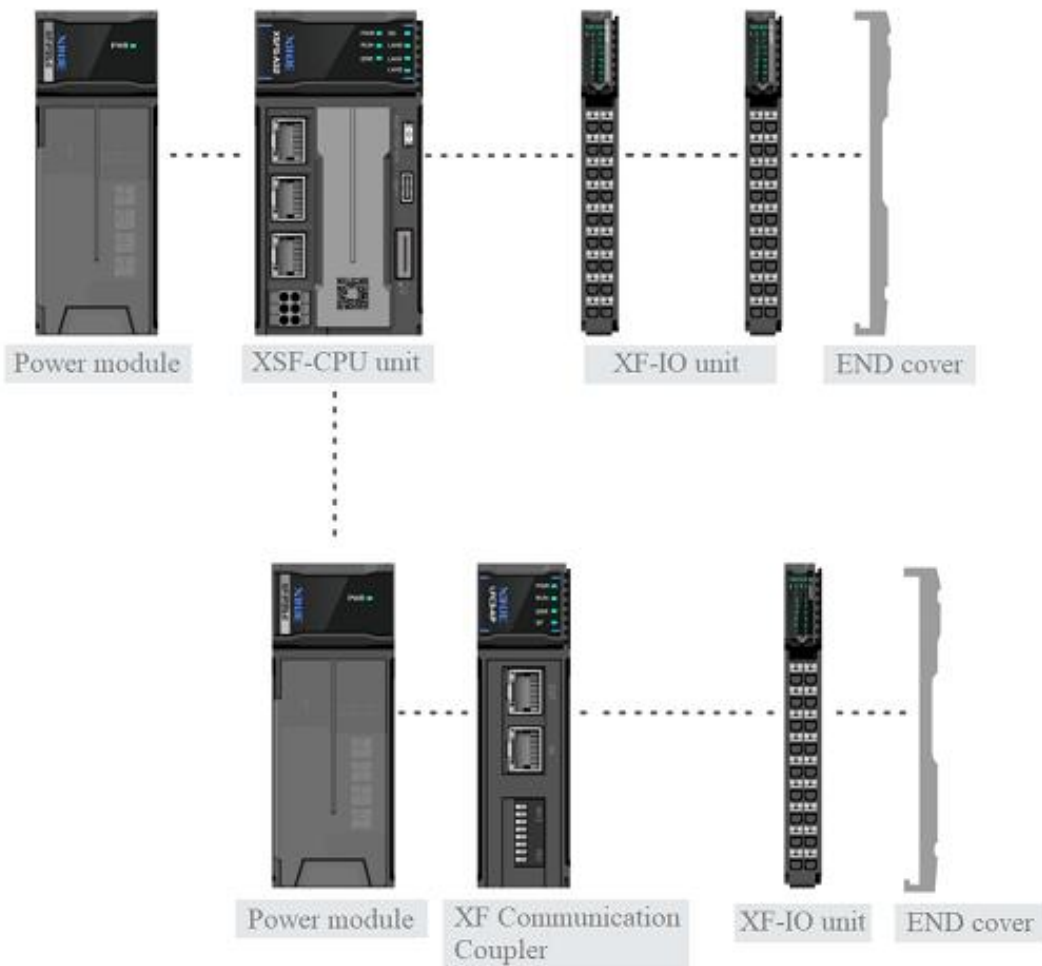

3.2 Key Points

- If different CPU units are used, the corresponding expandable IO units will also differ.
- If different power supply units are used, the IO units that can be powered through the backplane bus will also differ.

The types and quantities of CPU units and expandable IO units are as follows:

CPU unit model	Expandable basic I/O unit
XSF5-A8	32
XSF5-A16	
XSF5-A32	
XSF5-A64	

4. Power module unit XF-P35-E

4.1 Product Overview

The XF-P35-E series power module provides power to CPU units and coupler units, and supplies system power to expansion units. It is compatible with XF and XSF series CPU units and XF series communication coupler units.

- AC input;
- Double grounding;
- Overload protection
- Module Version

Hardware version	Function
H2.0	Basic functions for the first official production

4.2 Naming Rules

$$\begin{array}{ccccccccc} \text{XF} & - & \text{E} & \text{P} & \square & - & \bigcirc \\ \textcircled{1} & & \textcircled{2} & \textcircled{3} & \textcircled{4} & & \textcircled{5} \end{array}$$

①	Series name	XF:	XF series expansion module
②	Referential extension module	E:	Right Extension Module
③	Module type	P:	Power-supply module
④	output power	35:	35W output power
⑤	Input type	E:	AC input
		C:	DC input

4.3 Module View

1) Explanation of each part

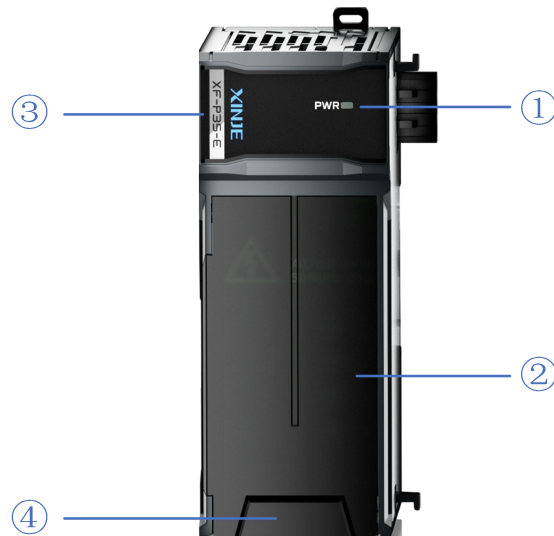

Number	Name	Number	Name
①	System LED indicator lights	②	Input terminal station
③	Model indication	④	Protective cover plate

2) System Indicator Light

System Indicator Light	Meaning	
PWR	Off	No input power
	Steady ON(green)	The power module receives normal input power and supplies power to the CPU unit.
	Steady ON(red)	The power module receives normal input power but fails to supply power to the CPU unit.

4.4 General Specifications

Project		Description
Operating temperature	Max temperature	55°C
	Min temperature	-20°C
Transportation/Storage Temperature	Max temperature	70°C
	Min temperature	-40°C

Project		Description
Environmental Humidity (including operation/storage)	Upper limit	95%
	lower limit	10%
Protection Grade		IP20
Anti vibration		Complies with IEC61131-2 under intermittent vibration (frequency 5-9Hz, constant amplitude 3.5mm peak displacement) and (frequency 9-150Hz, constant acceleration 1.0g peak acceleration) The continuous shock vibration (5-9Hz, half amplitude 1.75mm displacement) and (9-150Hz, constant acceleration 0.5g, constant frame amplitude) Scan 10 times in each of the X, Y, and Z directions
Impact resistance		Complies with IEC61131-2 standards; Impact intensity of 15G (peak) was applied for 11ms on each of three mutually perpendicular axes, with 3 impacts per axis (total 18 impacts).
Operating environment		Non-corrosive gases
Operating altitude		0-2000 meters
Overvoltage level		II: Complies with IEC61131-2
Pollution level		2; Complies with IEC61131-2
Anti interference EMC		Complies with IEC 61131-2 and IEC 61000-6-4 Type B
Relevant certifications		CE

4.5 Technical Specifications

Project		Description
Model		XF-P35-E
Power		35W
Input power	L,N	Input: AC 100-240V 50/60Hz
LG- Protective grounding		Protective grounding for equipment and operators, compliant with the functional protection requirements of IEC 61131-2 and GB/T 15969.2 standards.
FG-Functional grounding		Functional grounding terminals, used for non-safety purposes such as improving electromagnetic interference resistance. (Complies with the functional grounding requirements in IEC 61131-2 and GB/T 15969.2 standards)
Allowable Instant Power Outage Time		20ms or less
Dash current		20A 8ms or less
Module weight		199g

4.6 Installation & Wiring

4.6.1 Appearance dimension

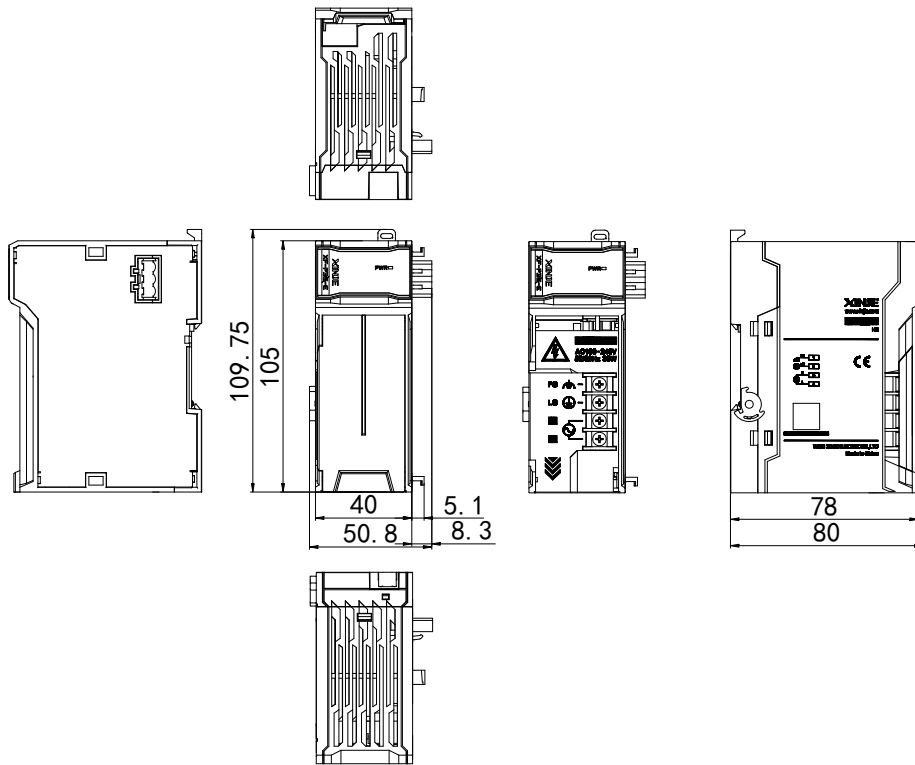

(unit :mm)

4.6.2 Installation Method

The module is mounted using DIN rails that comply with IEC 60715 standards (35mm wide, 1mm thick). The dimensions are shown in the figure below, with measurements in millimeters.

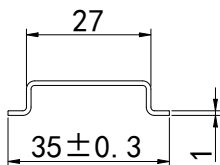

Attention

When the module is installed on a DIN rail not recommended above, the DIN rail latch may fail to lock properly.

4.6.3 Installation Environment

This product supports four installation orientations: horizontal, vertical, top-mounted on electrical cabinets, and bottom-mounted. Horizontal installation is recommended. The cooling system utilizes natural convection. To ensure proper ventilation and heat dissipation while providing sufficient wiring space, a minimum clearance must be maintained around the product, as shown in the figure below.

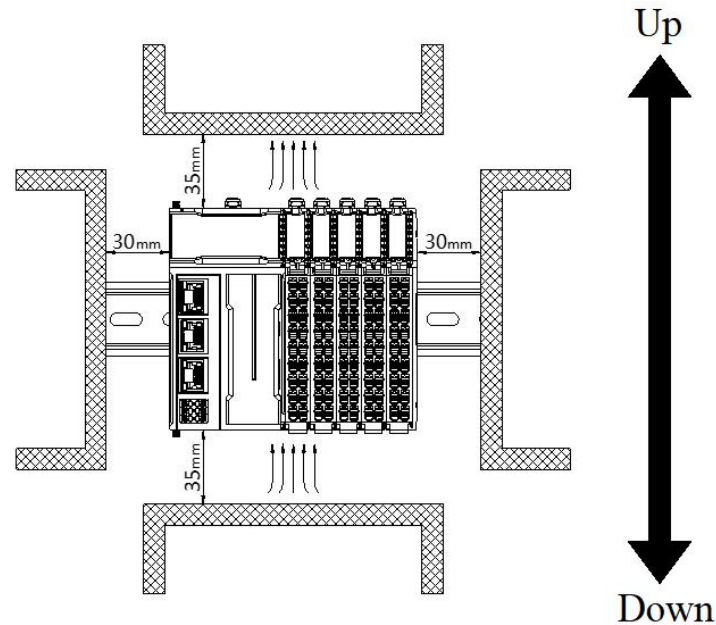

If there are high-temperature heat source devices (heaters, transformers, large resistors, etc.) near this product, a minimum clearance of 100mm must be maintained between the product and the high-temperature heat source devices.

5. Repeater Power Supply Module XF-EP24

5.1 Product Overview

The XF-EP24 is a repeater power module in the XF series, delivering DC24V power to the rear panel bus or system after relay power supply.

- DC24V DC input;
- Double grounding;
- Overload protection;
- Module Version

Hardware version	Function
H2.0	The basic functions are now officially operational for the first time.

5.2 Naming Rules

$\frac{\text{XF}}{\textcircled{1}} - \frac{\text{E}}{\textcircled{2}} \frac{\text{P}}{\textcircled{3}} \frac{\square}{\textcircled{4}} - \frac{\text{O}}{\textcircled{5}}$

①	Series name	XF:	XF series expansion module
②	Referential extension module	E:	Right Extension Module
③	Module type	P:	Power-supply module
④	Output power	24:	24W output power

5.3 Module View

1) Description of each part

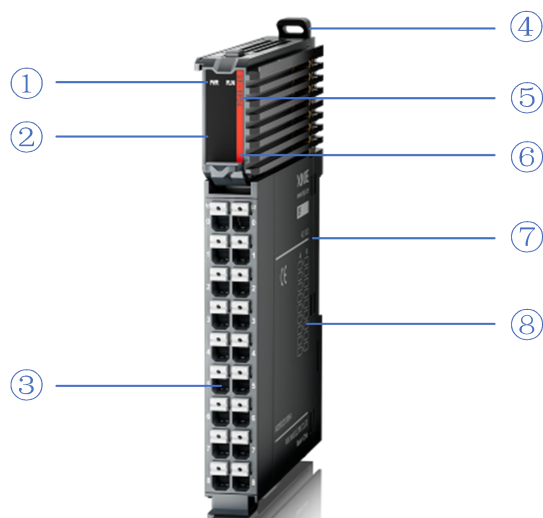

Number	Name	Nnumber	Name
①	System LED indicator lights	②	Channel LED indicator
③	Disconnectable terminal block	④	Fastener
⑤	Signal indication	⑥	Color coding for module type indication
⑦	Module hardware and Firmware version	⑧	Hookup

2) System Indicator Light

System Indicator Light	Meaning	
PWR (green)	Off	Module not powered on (backplane bus)
	Steady ON	All external power supplies for the module are functioning normally (backplane bus power and external 24V input).
	Flash 1Hz*1	Partial module power supply is abnormal and cannot operate normally (external)
RUN (green)	Steady ON	The module is running normally
	Flash 1Hz*1	The module encountered a general error in the log
	Off	The module encountered a critical error in the log
	10Hz*2	Modeling communication



- *1: The duty cycle is 50%, and the frequency is 1Hz, with a square wave.
- *2: The duty cycle is 50%, and the frequency is 10Hz, with a square wave.

3) Color identification

Number	Color	Module type
1	Grey White	Digital input
2	Gray	Digital output & digital mixing module
3	Light blue	Analogue input
4	Dark blue	Analog output
5	Green	232&485 serial communication
6	Pink	Temperature signal input
7	White	High speed counting
8	Purple	Pulse output
9	Red	Repeater power supply

5.4 General Specifications

Project		Description
Operating temperature	Max temperature	55°C
	Min temperature	-20°C
Transportation/Storage Temperature	Max temperature	70°C
	Min temperature	-40°C
Environmental humidity (including operation/storage)	Upper limit	95%
	lower limit	10%
Protection grade		IP20
Anti vibration		Complies with IEC61131-2 under intermittent vibration (frequency 5-9Hz, constant amplitude 3.5mm peak displacement) and (frequency 9-150Hz, constant acceleration 1.0g peak acceleration) The continuous shock vibration (5-9Hz, half amplitude 1.75mm displacement) and (9-150Hz, constant acceleration 0.5g, constant frame amplitude) Scan 10 times in each of the X, Y, and Z directions
Impact resistance		Complies with IEC61131-2 standards; Impact intensity of 15G (peak) was applied for 11ms on each of three mutually perpendicular axes, with 3 impacts per axis (total 18 impacts).
Operating environment		Non-corrosive gases
Operating altitude		0-2000 meters
Overvoltage level		II: Complies with IEC61131-2
Pollution level		2; Complies with IEC61131-2

Project	Description
Anti interference EMC	Complies with IEC 61131-2 and IEC 61000-6-4 Type B
Relevant certifications	CE

5.5 Technical Specifications

Project		Description
Model		XF-EP24
Bus Output	Rated voltage	DC 24V
	Rated current	1A
Module power supply	Protect	Reverse protection
	Rated input	DC24V(21.6V~26.4V), 1A
Output protection		Short-circuit protection (self-recovery), overload protection (30%)
Power conversion efficiency		70%
Occupied slot		Occupies 1 slot
Isolated Power Supply		Non support
Module weight		74g

5.6 Installation & Wiring

5.6.1 Appearance dimension

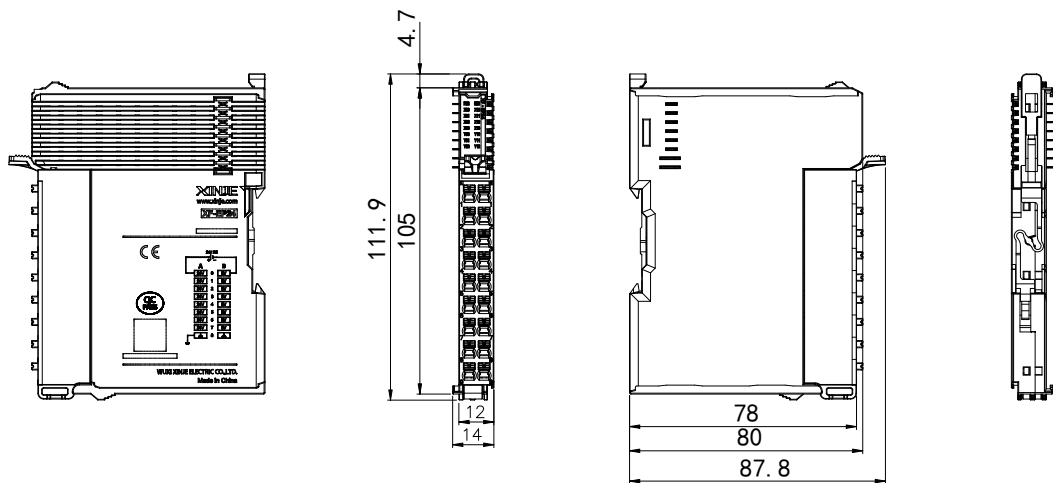

(unit :mm)

5.6.2 Terminal Definition & Wiring

1) Terminal definition

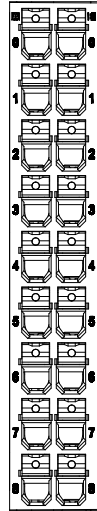
XF-EP24				
Meaning	A-list terminal	Terminal layout	B-list terminal	Meaning
24V Positive	0		0	0V
24V Positive	1		1	0V
24V Positive	2		2	0V
24V Positive	3		3	0V
24V Positive	4		4	0V
24V Positive	5		5	0V
24V Positive	6		6	0V
24V Positive	7		7	0V
PE (Protective grounding)	8		8	PE (Protective grounding)

2) External wiring

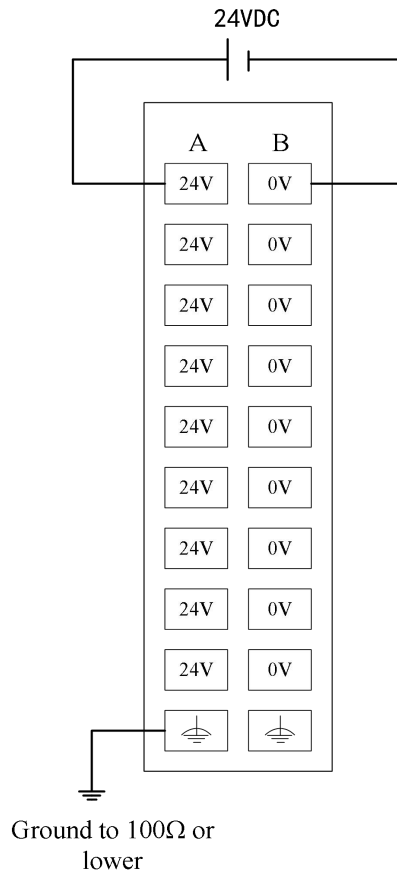

5.6.3 Installation Method

The module is mounted using DIN rails that comply with IEC 60715 standards (35mm wide, 1mm thick). The dimensions are shown in the figure below, with measurements in millimeters.

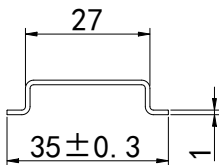

Attention

When the module is installed on a DIN rail not recommended above, the DIN rail latch may fail to lock properly.

5.6.4 Installation Environment

This product supports four installation orientations: horizontal, vertical, top-mounted on electrical cabinets, and bottom-mounted. Horizontal installation is recommended. The cooling system utilizes natural convection. To ensure proper ventilation and heat dissipation while providing sufficient wiring space, a minimum clearance must be maintained around the product, as shown in the figure below.

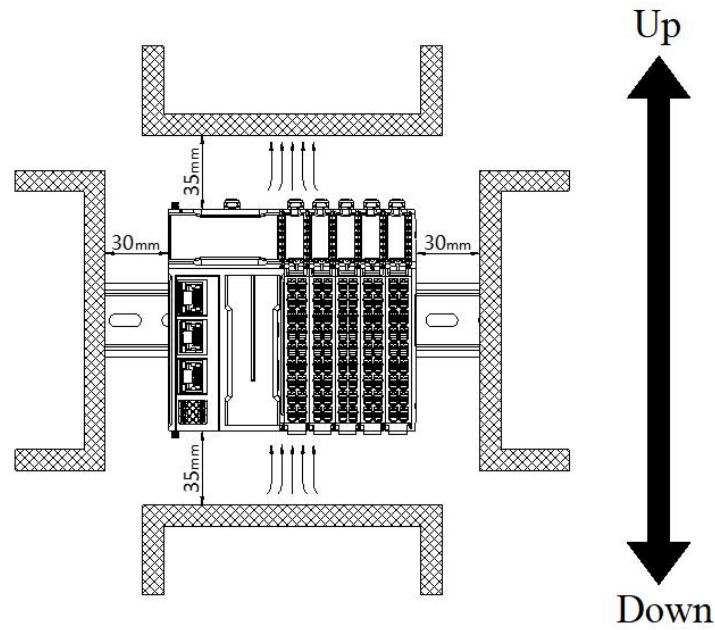

If the product is surrounded by high-temperature heat source equipment (heaters, transformers, large resistors, etc.), maintain a minimum gap of 100mm between the product and such equipment.

5.7 Parameters and Mapping Addresses

Name	Type	Description
XF-EP24	Stuct	XF repeater power module
— ErrCode_module	WORD	Module-level error code

■ Error code parameter

ErrCode_module		
Bit	Meaning	Error level
0	The module's 24V input power supply is malfunctioning.	Critical
2	An internal module error occurred and the user layer cannot fix it	Critical
3	Version mismatch	Critical

6. Digital Quantity Module Unit

6.1 Naming Rules

$\text{XF} - \text{E} \quad \text{○} \quad \text{□} \quad \text{X} \quad \text{□} \quad \text{○} \quad \text{Y} \quad \text{□}$
 ① ② ③ ④ ⑤ ⑥ ⑦ ⑧ ⑨

①	Series name	XF: XF series expansion module
②	Extension module	E: Right Extension Module
③	Input channel	4: 4 channel
		8: 8 channel
		16: 16 channel
		32: 32 channel
		64: 64 channel
④	Input point type	Empty: Digital input compatible with PNP and NPN transistors N: Digital input type: NPN P: Digital input type: PNP
⑤	Type	X: digital input
⑥	Output channel	4: 4 channel
		8: 8 channel
		16: 16 channel
		32: 32 channel
		64: 64 channel
⑦	Output type	Empty: Digital output, NPN type P: Digital output, PNP type
⑧	Type	Y: Digital output
⑨	Output point type	T: Type of digital output transistor R: Type of digital output relay

6.2 Digital Input Unit XF-E16X

6.2.1 Product Overview

The XF-E16X series digital input expansion module features 16-channel digital inputs with NPN and PNP support, compatible with XF/XSF series CPU units and XF series communication couplers.

- 16-channel digital input;
- Complies with IEC-61131 Input Standard Type 1;
- NPN and PNP bipolar inputs;
- 12mm width design.

■ Module Version

Hardware version	Firmware version	Function
H2.0	V2.0	The basic functions are now officially operational for the first time.

6.2.2 Module View

1) Explanation of each part

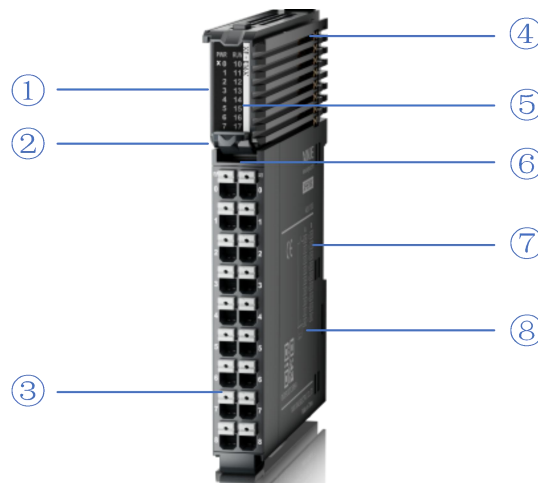

Number	Name	Number	Name
①	System LED indicator lights	②	Channel LED indicator light
③	Disconnectable terminal block	④	Fastener
⑤	Signal indication	⑥	Color coding for module type indication
⑦	Module hardware and Firmware version	⑧	Hookup

2) System Indicator Light

System Indicator Light	Meaning	
PWR (green)	Off	Module not powered on
	Steady ON	All external power supplies of the module are normal (Back plane bus power supply & external input 24V)
RUN (green)	Steady ON	The module is operating normally
	Flash 1Hz*1	Mild errors in module logs
	Off	Critical errors in the module log
	Flash 10Hz*2	Module establishing communication
	Double Flash*3	Module firmware update



- *1: A square wave with a duty cycle of 50% and a frequency of 1Hz.
- *2: A square wave with a duty cycle of 50% and a frequency of 10Hz.
- *3: The following figure:

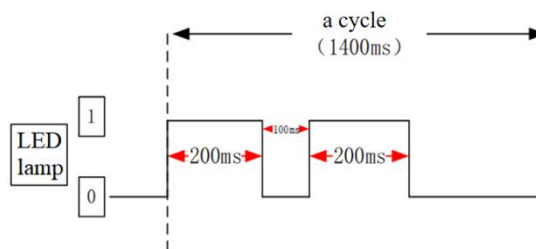

3) Channel indicator light light

Model	Channel indicator light light		
XF-E16X	X0-X17	Steady ON (green)	Corresponding input channel has input ON signal
		Off	Corresponding input channel has no input ON signal

4) Color identification

Number	Color	Module type
1	Grey White	Digital input
2	Gray	Digital output & digital mixing module
3	Light blue	Analogue input
4	Light blue	Analog output
5	Green	232&485 serial communication
6	Pink	Temperature signal input
7	White	High speed counting
8	Purple	Pulse output
9	Red	Repeater power supply

6.2.3 General Specifications

Project		Description
Operating temperature	Max temperature	55°C
	Min temperature	-20°C
Transportation/Storage Temperature	Max temperature	70°C
	Min temperature	-40°C
Environmental humidity (including operation/storage)	Upper limit	95%
	Lower limit	10%
Protection grade		IP20
Anti vibration		Complies with IEC61131-2 under intermittent vibration (frequency 5-9Hz, constant amplitude 3.5mm peak displacement) and (frequency 9-150Hz, constant acceleration 1.0g peak acceleration) The continuous shock vibration (5-9Hz, half amplitude 1.75mm displacement) and (9-150Hz, constant acceleration 0.5g, constant frame amplitude) Scan 10 times in each of the X, Y, and Z directions
Impact resistance		Complies with IEC61131-2 standards; Impact intensity of 15G (peak) was applied for 11ms on each of three mutually perpendicular axes, with 3 impacts per axis (total 18 impacts).
Operating environment		Non-corrosive gases
Operating altitude		0-2000 meters
Overvoltage level		II: Complies with IEC61131-2
Pollution level		2: Complies with IEC61131-2
Anti interference EMC		Complies with IEC 61131-2 and IEC 61000-6-4 Type B
Relevant certifications		CE

6.2.4 Technical Specifications

Project	Description
Input points	16
Rated input voltage	DC24V
Rated input current	4mA
Input impedance	5.5KΩ
Input on voltage	15V
Input on current	2.5mA

Project	Description
Input off voltage	5V
Input off current	1mA
Input resistance ON → OFF response time (Hardware)	0.1ms
Input resistance OFF → ON response time (Hardware)	0.1ms
Input derating	Derate by 75% when operating at 60 °C (with no more than 12 ON input points), or by 10 °C when all input points are ON.
Common connection method	1 common terminal of 16 points
Wiring method	For example, external terminal connection diagram
Module power consumption	0.5W (internal backplane) + 1.4W (external input)
Module weight	80g

6.2.5 Installation & Wiring

6.2.5.1 Appearance dimensions

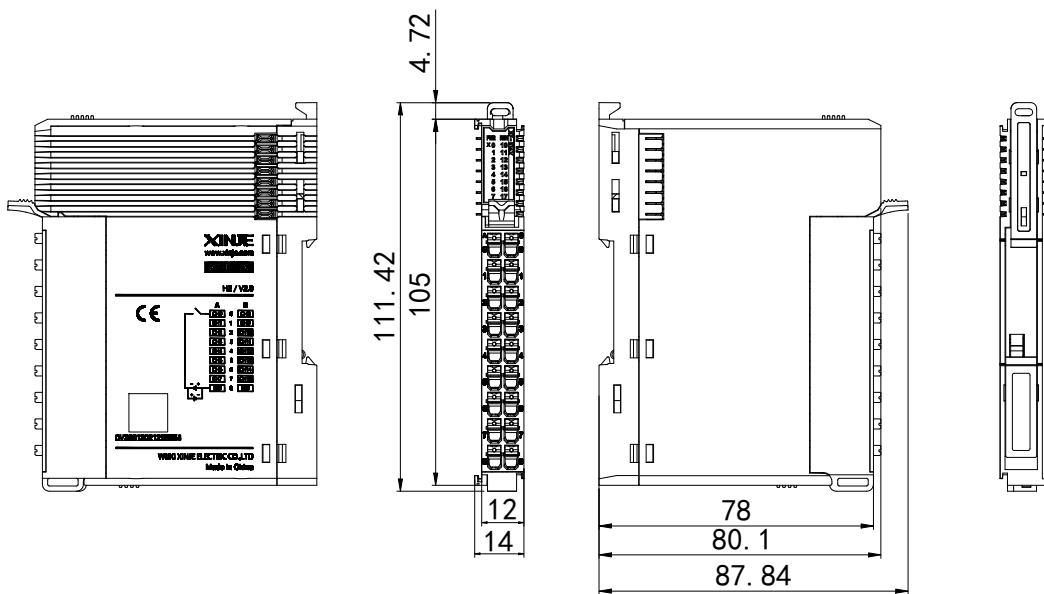

(unit: mm)

6.2.5.2 Terminal Definitions & Wiring

1) Terminal definition

XF-E16X				
Meaning	A-list terminal	Terminal layout	B-list terminal	Meaning
CH0	0		0	CH8
CH1	1		1	CH9
CH2	2		2	CH10
CH3	3		3	CH11
CH4	4		4	CH12
CH5	5		5	CH13
CH6	6		6	CH14
CH7	7		7	CH15
SS	8		8	SS



Two SS (solid-state) internal short circuits, so all input points of a single module can only choose either NPN or PNP.

NPN: S/S terminal connects to 24V, and terminals 0-7 in columns A and B connect to 0V.

PNP: S/S terminal connects to 0V, and terminals 0-7 in columns A and B connect to 24V.

2) External wiring

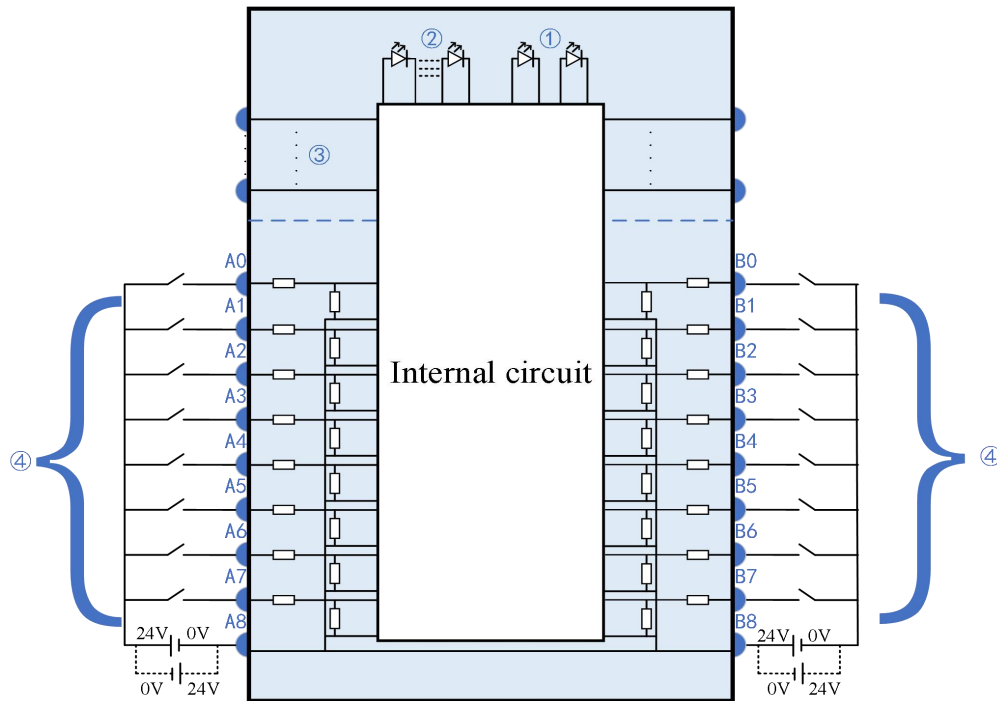

① System Indicator Light ② Channel indicator light light ③ backplane bus ④ Input channel& wiring

6.2.5.3 Installation Method

1) Installation requirements

The module is mounted using DIN rails that comply with IEC 60715 standards (35mm wide, 1mm thick). The dimensions are shown in the figure below, with measurements in millimeters.

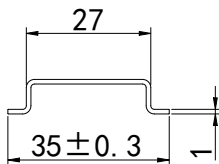

Attention

When the module is installed on a DIN rail not recommended above, the DIN rail latch may fail to lock properly.

2) Installation Steps

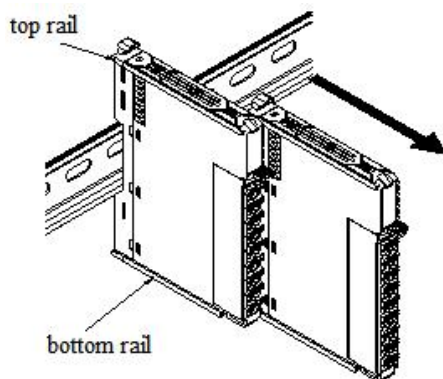

1. The IO modules are assembled by sliding along the top and bottom rails, as shown in the left figure.

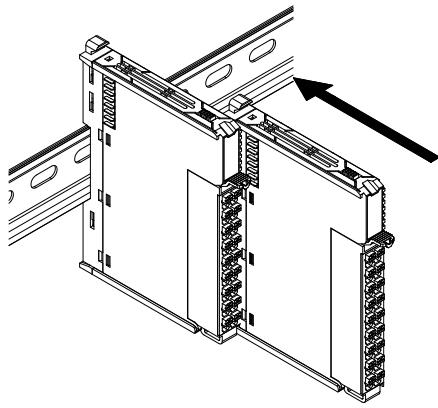

2. The module is mounted on the guide rail. During installation, align the module with the DIN guide rail and press it in the direction indicated by the arrow. A clear click sound will be heard when the module is properly secured, as shown in the left image.

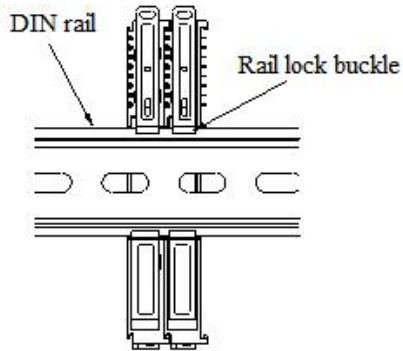

3. After module installation, the latch will automatically lower to lock. If it doesn't move down, press the top of the latch downward to ensure proper installation.

3) Disassembly steps

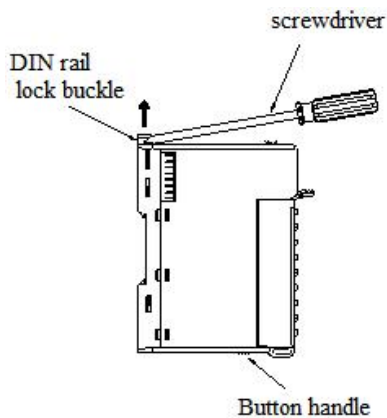

1. Use a screwdriver or similar tool to pry up the guide rail lock, as shown in the left image:

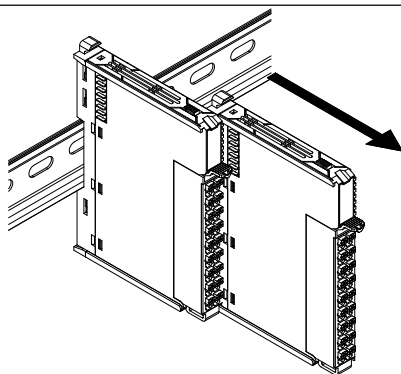

2. Pull the module straight forward from the buckle position (the raised part), then press down the top of the buckle as shown in the left image.

6.2.5.4 Installation Environment

This product supports four installation orientations: horizontal, vertical, top-mounted on electrical cabinets, and bottom-mounted. Horizontal installation is recommended. The cooling system utilizes natural convection. To ensure proper ventilation and heat dissipation while providing sufficient wiring space, a minimum clearance must be maintained around the product, as shown in the figure below.

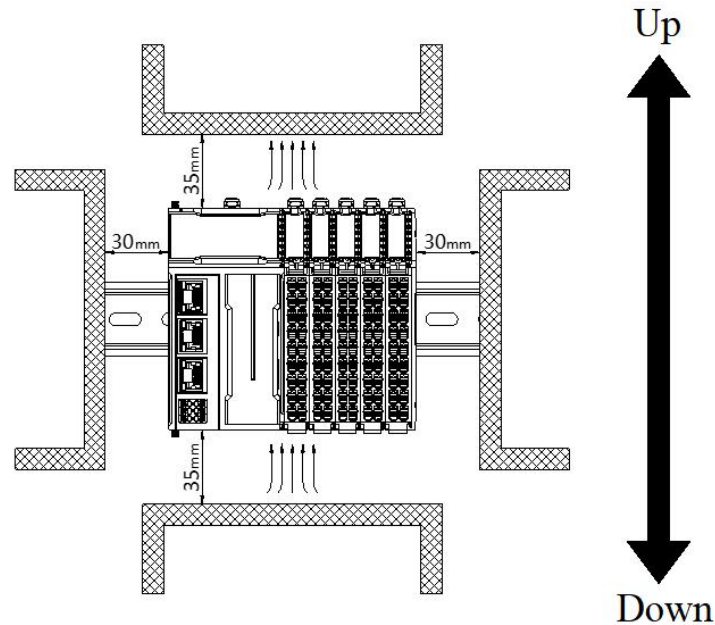

If the product is surrounded by high-temperature heat source equipment (heaters, transformers, large resistors, etc.), maintain a minimum gap of 100mm between the product and such equipment.

6.2.5.5 Equipment Wiring

When wiring the module, the connectors must meet the following requirements:

Compatible Wire Diameter	
Chinese standard/mm2	American-Standard /AWG
0.3	22
0.5	20
0.75	18
1.0	18
1.5	16

If using other wire-type terminal lugs, press them onto the stranded wire as shown in the figure below for shape and size requirements.

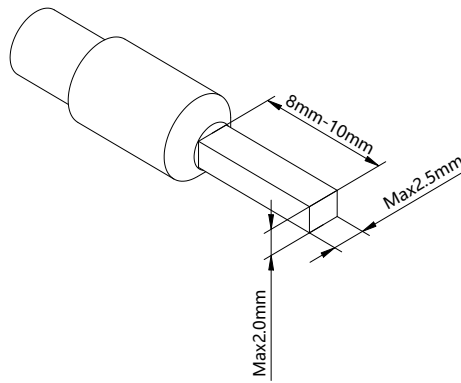

6.2.6 Parameters and Mapping Addresses

Name	Type	Description
XF_E16X	Stuct	16-channel input module
CH0	BOOL	Channel 0 input value
CH1	BOOL	Channel 1 input value
CH2	BOOL	Channel 2 input value
CH3	BOOL	Channel 3 input value
CH4	BOOL	Channel 4 input value
CH5	BOOL	Channel 5 input value
CH6	BOOL	Channel 6 input value
CH7	BOOL	Channel 7 input value
CH8	BOOL	Channel 8 input value
CH9	BOOL	Channel 9 input value
CH10	BOOL	Channel 10 input value
CH11	BOOL	Channel 0 input value
CH12	BOOL	Channel 0 input value
CH13	BOOL	Channel 11 input value
CH14	BOOL	Channel 12 input value
CH15	BOOL	Channel 13 input value
ErrCode_module	WORD	Module-level error code
ErrCode_CH	DWORD	Channel level error code

■ Error code parameter

ErrCode_module		
Bit	Meaning	Error level
0	Not applicable	
2	An internal module error occurred and the user layer cannot fix it	Critical
3	Version mismatch	Critical



Channel level error codes are reserved and not defined.

■ Configuration parameters

XF-E16X			
Variable name	Type	Meaning	Note
CH0_FilterTime	BYTE	Channel 0 input filter time	0: No filter 11: 9ms 1: 0.25ms 12: 10ms 2: 0.5ms 13: 11ms 3: 1ms 14: 12ms 4: 2ms 15: 13ms 5: 3ms 16: 14ms 6: 4ms 17: 15ms 7: 5ms 18: 20ms 8: 6ms 19: 30ms 9: 7ms 20: 64ms 10: 8ms 21: 128ms
CH1_FilterTime	BYTE	Channel 1 input filter time	
CH2_FilterTime	BYTE	Channel 2 input filter time	
CH3_FilterTime	BYTE	Channel 3 input filter time	
CH4_FilterTime	BYTE	Channel 4 input filter time	
CH5_FilterTime	BYTE	Channel 5 input filter time	
CH6_FilterTime	BYTE	Channel 6 input filter time	
CH7_FilterTime	BYTE	Channel 7 input filter time	
CH8_FilterTime	BYTE	Channel 8 input filter time	
CH9_FilterTime	BYTE	Channel 9 input filter time	
CH10_FilterTime	BYTE	Channel 10 input filter time	
CH11_FilterTime	BYTE	Channel 11 input filter time	
CH12_FilterTime	BYTE	Channel 12 input filter time	
CH13_FilterTime	BYTE	Channel 13 input filter time	
CH14_FilterTime	BYTE	Channel 14 input filter time	
CH15_FilterTime	BYTE	Channel 15 input filter time	
CH0-7_Input_Logiclevel	BYTE	Channel 0~7 logic level configuration	0: Positive logic 1: Negative logic bit0~bit7 correspond to channels 0~7; bit8~bit15 correspond to channels 8~15
CH8-15_Input_Logiclevel	BYTE	Channel 8-15 logic level configuration	

6.2.7 Functions and Settings

■ Channel input filter time

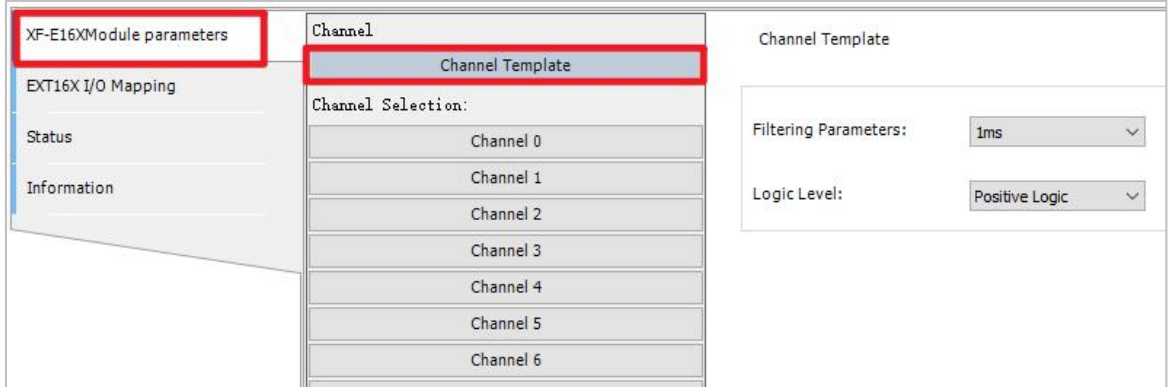

Parameter	Initial Value	Parameter Description																	
Filter Parameter	1ms	When there is a signal at the input terminal and the signal duration exceeds the filter time, it is regarded as a valid signal. Configurable parameters: Available options (displayed in a drop-down list): 0ms, 0.25ms, 0.5ms, 1ms, 2ms, 3ms, 4ms, 5ms, 6ms, 7ms, 8ms, 9ms, 10ms, 11ms, 12ms, 13ms, 14ms, 15ms, 20ms, 30ms, 64ms, 128ms																	
Logic Level	Positive Logic	<p>Program execution logic after external signal input.</p> <table border="1"> <thead> <tr> <th>External Input Signal</th> <th>Logic Level Configuration</th> <th>Running Program</th> <th>Operation Result</th> </tr> </thead> <tbody> <tr> <td>X0=1</td> <td>Positive Logic</td> <td rowspan="4">LD X0; OUT Y0;</td> <td>Y0=1</td> </tr> <tr> <td>X0=1</td> <td>Negative Logic</td> <td>Y0=0</td> </tr> <tr> <td>X0=0</td> <td>Positive Logic</td> <td>Y0=0</td> </tr> <tr> <td>X0=0</td> <td>Negative Logic</td> <td>Y0=1</td> </tr> </tbody> </table>	External Input Signal	Logic Level Configuration	Running Program	Operation Result	X0=1	Positive Logic	LD X0; OUT Y0;	Y0=1	X0=1	Negative Logic	Y0=0	X0=0	Positive Logic	Y0=0	X0=0	Negative Logic	Y0=1
External Input Signal	Logic Level Configuration	Running Program	Operation Result																
X0=1	Positive Logic	LD X0; OUT Y0;	Y0=1																
X0=1	Negative Logic		Y0=0																
X0=0	Positive Logic		Y0=0																
X0=0	Negative Logic		Y0=1																

■ channel logic level

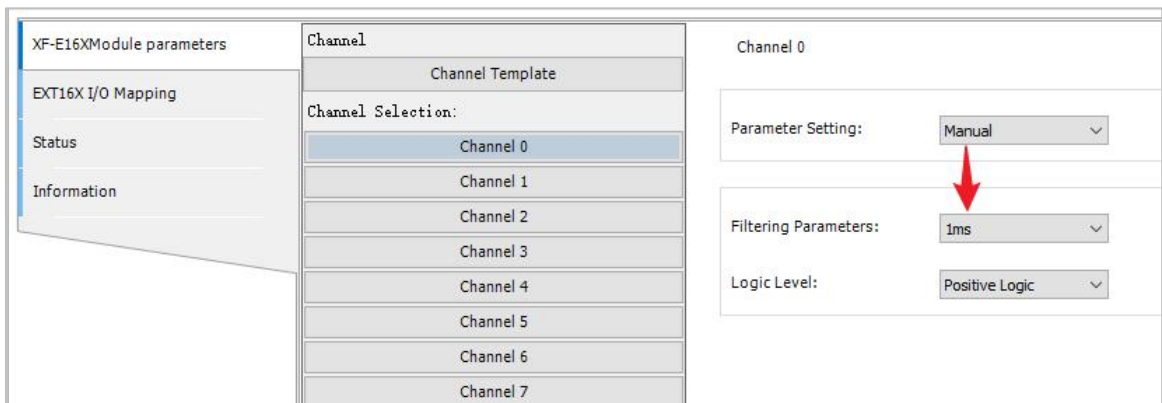

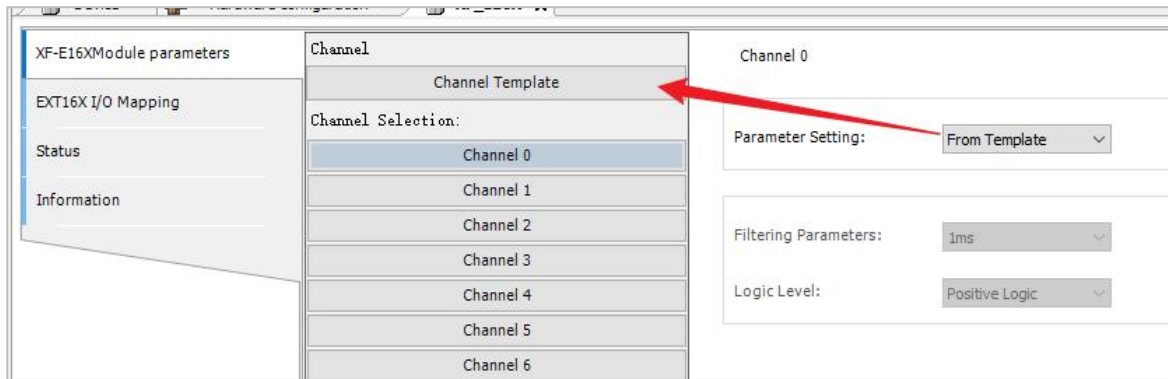

You can set the filter parameters and logic level for each channel individually.

Channel Settings	<p>From Template: Use the configuration parameters of the "Channel Template" interface</p> <p>Manual: Use the configuration parameters below this interface</p>
------------------	---

6.3 Digital Output Unit XF-E16 (P)YT

6.3.1 Product Overview

The XF series digital output expansion module features 16-channel digital outputs, compatible with XF/XSF series CPU units and XF series communication coupler units.

- 16-channel digital output
- NPN, PNP output
- 12mm width design

■ Model Description

Model		Function
NPN output type	PNP output type	
XF-E16YT	XF-E16PYT	16-channel transistor output

■ Module Version

Model	Hardware version	Firmware version	Function
XF-E16YT	H2.0	V2.0	Basic functions for the first official production.
XF-E16PYT	H2.0	V2.0	Basic functions for the first official production.

6.3.2 Module View

1) Explanation of each part

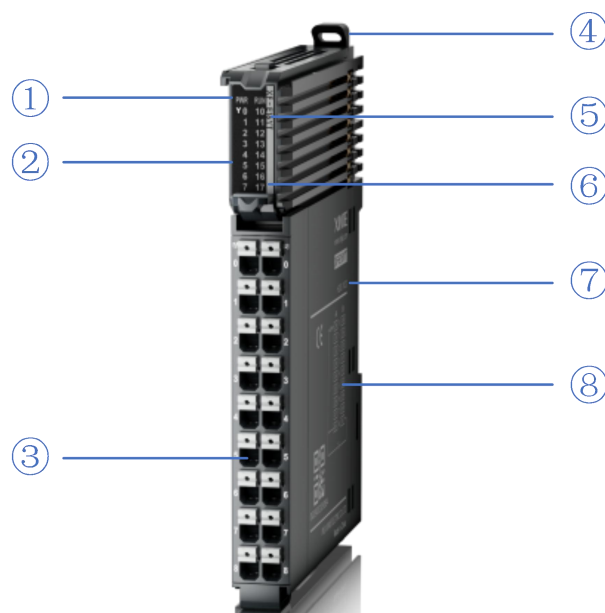

Number	Name	Number	Name
①	System LED indicator lights	②	Channel LED indicator light
③	Disconnectable terminal block	④	Fastener
⑤	Signal indication	⑥	Color coding for module type indication
⑦	Module hardware and Firmware version	⑧	Hookup

2) System Indicator Light

System Indicator Light	Meaning	
PWR (green)	Off	Module not powered on (backplane bus)
	Steady ON	All external power supplies for the module are functioning normally (ba ckplane bus power and external 24V input).
	Flash 1Hz*1	Partial module power supply is abnormal and cannot operate normally (external)
RUN (green)	Steady ON	The module is operating normally
	Flash 1Hz*1	Mild errors in module logs
	Off	Critical errors in the module log
	10Hz*2	Module establishing communication
	Dual Flash*3	Module firmware updating



- *1: A square wave with a duty cycle of 50% and a frequency of 1Hz.
- *2: A square wave with a duty cycle of 50% and a frequency of 10Hz.
- *3: The following figure:

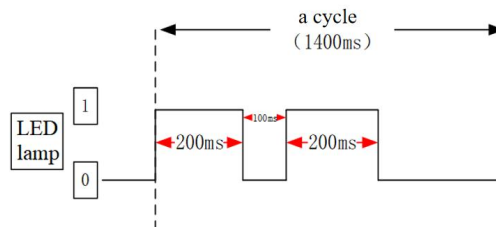

3) Channel indicator light light

Model	Channel indicator light light		
XF-E16(P)YT	Y0-Y17	Steady ON (green)	Corresponding input channel has input ON signal
		Off	Corresponding input channel has no input ON signal

4) Color identification

Number	Color	Module type
1	Grey White	Digital input
2	Gray	Digital output & digital mixing module
3	Light blue	Analogue input
4	Dark blue	Analog output
5	Green	232&485 serial communication
6	Pink	Temperature signal input
7	White	High speed counting
8	Purple	Pulse output
9	Red	Repeater power supply

6.3.3 General Specifications

Project		Description
Operating temperature	Max temperature	55°C
	Min temperature	-20°C
Transportation/Storage Temperature	Max temperature	70°C
	Min temperature	-40°C
Environmental humidity (including operation/storage)	Upper limit	95%
	lower limit	10%
Protection grade		IP20
Anti vibration		Complies with IEC61131-2 under intermittent vibration (frequency 5-9Hz, constant amplitude 3.5mm peak displacement) and (frequency 9-150Hz, constant acceleration 1.0g peak acceleration) The continuous shock vibration (5-9Hz, half amplitude 1.75mm displacement) and (9-150Hz, constant acceleration 0.5g, constant frame amplitude) Scan 10 times in each of the X, Y, and Z directions
Impact resistance		Complies with IEC61131-2 standards; Impact intensity of 15G (peak) was applied for 11ms on each of three mutually perpendicular axes, with 3 impacts per axis (total 18 impacts).
Operating environment		Non-corrosive gases
Operating altitude		0-2000 meters
Overvoltage level		II: Complies with IEC61131-2
Pollution level		2; Complies with IEC61131-2
Anti interference EMC		Complies with IEC 61131-2 and IEC 61000-6-4 Type B

Project	Description
Relevant certifications	CE

6.3.4 Technical Specifications

Project	Description	
Model	XF-E16YT	XF-E16PYT
Output points	16	
Rated load voltage	DC24V(DC21.6V~26.4V)	
Maximum load current	0.5A per point, 4A per module (maximum 2A for 4 points)	
Surge current protection	Support	
Leakage current at OFF	Below 0.1mA	
Output ON→OFF response time (hardware)	0.1ms	
Output OFF→ON response time (hardware)	0.1ms	
Output derating	Derate 50% when operating at 55°C (while ensuring the ON-state output current does not exceed 2A), or derate by 10°C when all output points are ON.	
Public mode	1 common terminal of 16 points	
Output protection	Supports short-circuit and overload protection functions.	
Module dissipation	1.0W (internal backplane) + 0.8W (external input)	
Module weight	80g	

6.3.5 Installation & Wiring

6.3.5.1 Appearance dimensions

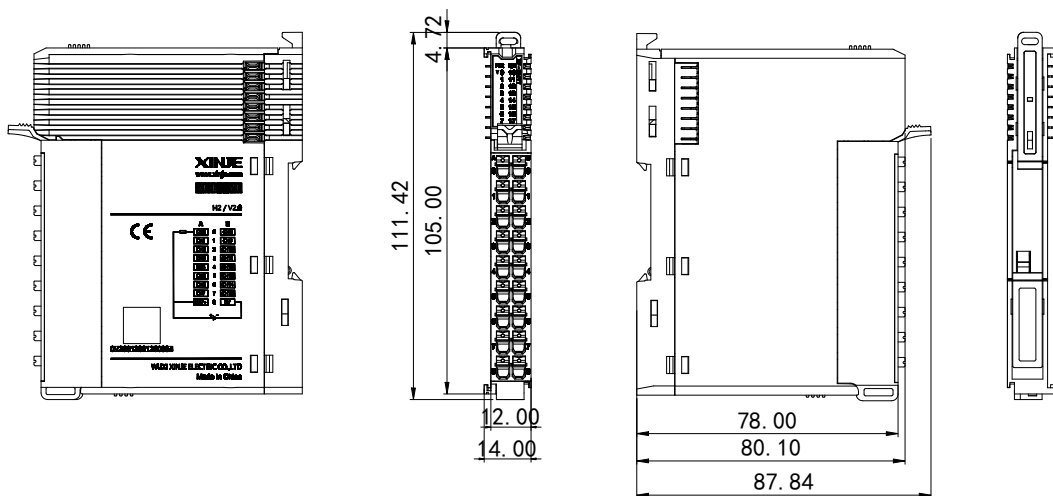

(unit: mm)

6.3.5.2 Terminal Definitions & Wiring

1) Terminal definition

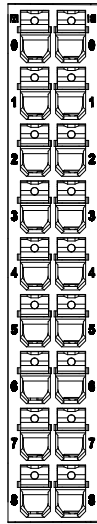
XF-E16(P)YT				
Meaning	A-list terminal	Terminal layout	B-list terminal	Meaning
CH0	0		0	CH8
CH1	1		1	CH9
CH2	2		2	CH10
CH3	3		3	CH11
CH4	4		4	CH12
CH5	5		5	CH13
CH6	6		6	CH14
CH7	7		7	CH15
External 24V DC power supply positive (+)	8		8	External 24V DC power supply negative (-)

2) External wiring

- XF-E16YT

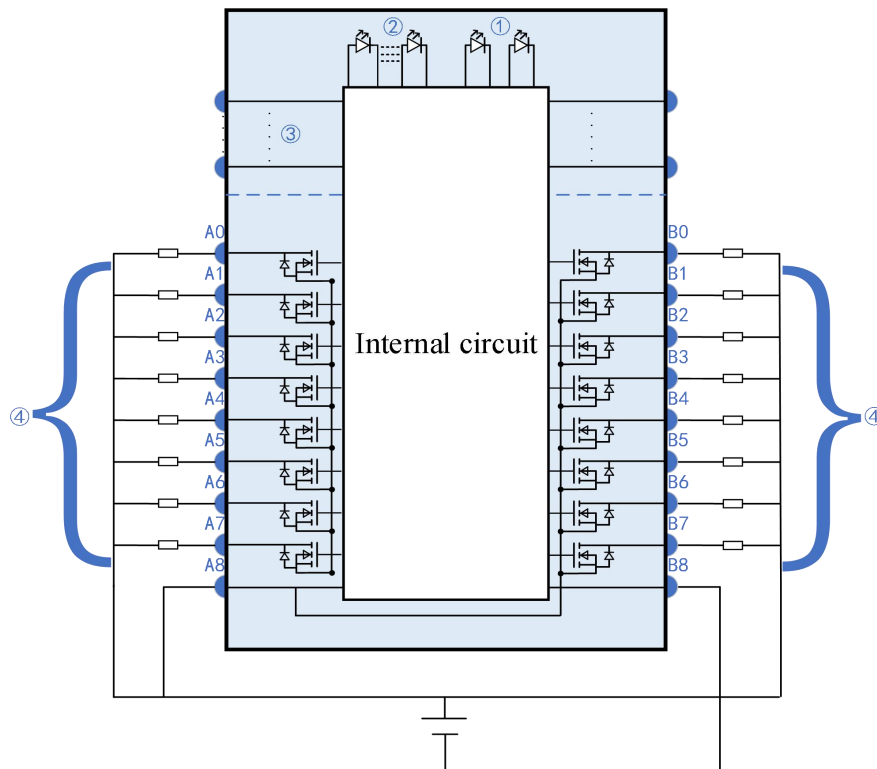

- ① System Indicator Light
- ② Channel indicator light
- ③ Backplane bus
- ④ Output channel & wiring

● XF-E16PYT

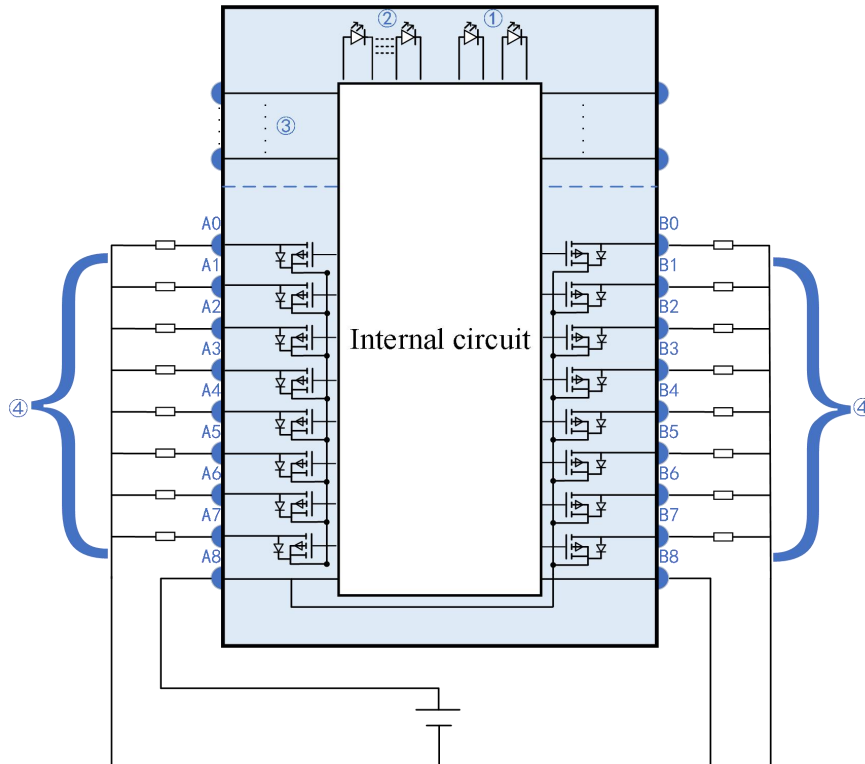

- ① System Indicator Light
- ② Channel indicator light
- ③ Backplane bus
- ④ Output channel & wiring light

6.3.5.3 Installation Method

1) Installation requirements

The module is mounted using DIN rails that comply with IEC 60715 standards (35mm wide, 1mm thick). The dimensions are shown in the figure below, with measurements in millimeters.

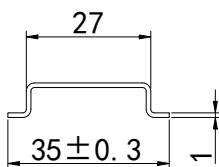

Attention

When the module is installed on a DIN rail not recommended above, the DIN rail latch may fail to lock properly.

2) Installation Steps

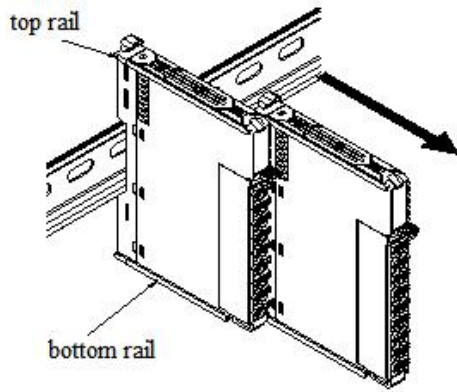

1. The IO modules are assembled by sliding along the top and bottom rails, as shown in the left figure.

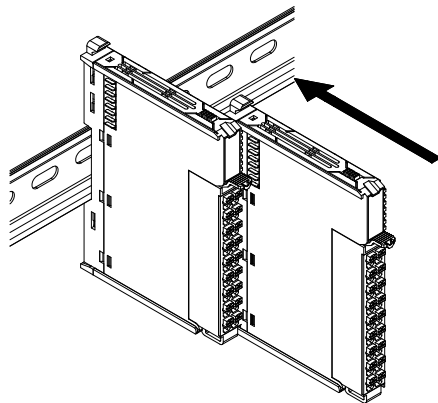

2. The module is mounted on the guide rail. During installation, align the module with the DIN guide rail and press it in the direction indicated by the arrow. A clear click sound will be heard when the module is properly secured, as shown in the left image.

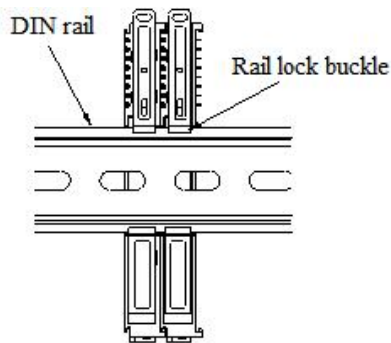

3. After module installation, the latch will automatically lower to lock. If it doesn't move down, press the top of the latch downward to ensure proper installation.

3) Disassembly steps

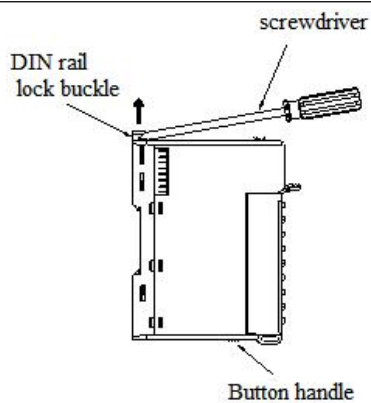

1. Use a screwdriver or similar tool to pry up the guide rail lock, as shown in the left image:

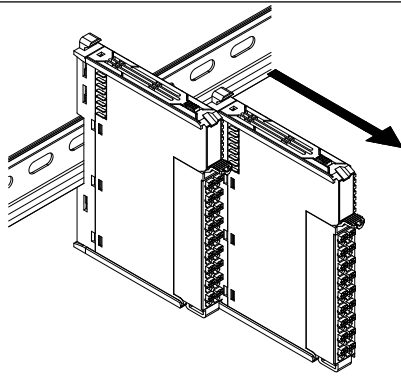

2. Pull the module straight forward from the buckle position (the raised part), then press down the top of the buckle as shown in the left image.

6.3.5.4 Installation Environment

This product supports four installation orientations: horizontal, vertical, top-mounted on electrical cabinets, and bottom-mounted. Horizontal installation is recommended. The cooling system utilizes natural convection. To ensure proper ventilation and heat dissipation while providing sufficient wiring space, a minimum clearance must be maintained around the product, as shown in the figure below.

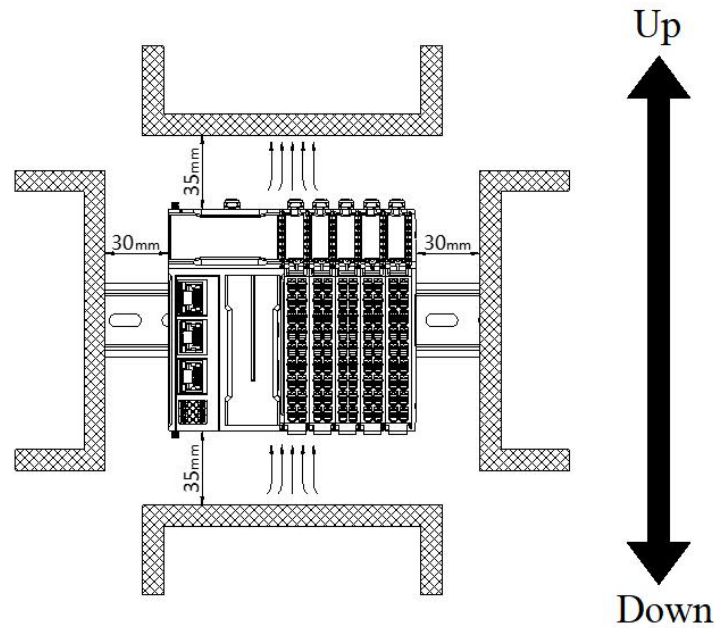

If the product is surrounded by high-temperature heat source equipment (heaters, transformers, large resistors, etc.), maintain a minimum gap of 100mm between the product and such equipment.

6.3.5.5 Equipment Wiring

When wiring the module, the connectors must meet the following requirements:

Compatible Wire Diameter	
China Standard/mm ²	American Standard /AWG
0.3	22
0.5	20

Compatible Wire Diameter	
China Standard/mm ²	American Standard /AWG
0.75	18
1.0	18
1.5	16

If using other wire-type terminal lugs, press them onto the stranded wire as shown in the figure below for shape and size requirements.

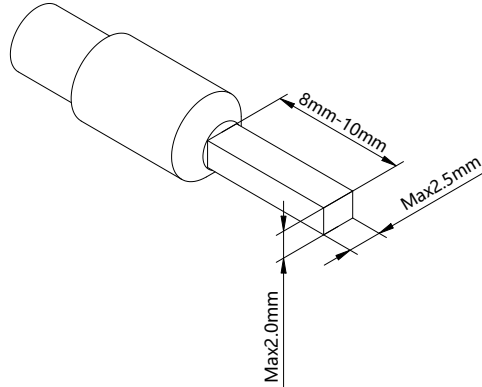

6.3.6 Parameters and Mapping Addresses

Name	Type	Description
XF_E16(P)YT	Stuct	16-Channel output module
— CH0	BOOL	Channel 0 output value
— CH1	BOOL	Channel 1 output value
— CH2	BOOL	Channel 2 output value
— CH3	BOOL	Channel 3 output value
— CH4	BOOL	Channel 4 output value
— CH5	BOOL	Channel 5 output value
— CH6	BOOL	Channel 6 output value
— CH7	BOOL	Channel 7 output value
— CH8	BOOL	Channel 8 output value
— CH9	BOOL	Channel 9 output value
— CH10	BOOL	Channel 10 output value
— CH11	BOOL	Channel 11 output value
— CH12	BOOL	Channel 12 output value

Name	Type	Description
XF_E16(P)YT	Stuct	16-Channel output module
CH13	BOOL	Channel 13 output value
CH14	BOOL	Channel 14 output value
CH15	BOOL	Channel 15 output value
ErrCode_module	WORD	Module-level error code
ErrCode_CH	DWORD	Channel level error code

■ Error code parameter

Module-level error code (ErrCode_module)		
Bit	Meaning	Error level
0	The 24V input power of the module is abnormal.	Critical
2	An internal module error occurred and the user layer cannot fix it	Critical
3	Version mismatch	Critical



Channel level error code reserved, currently undefined.

■ configuration parameter

XF-E16Y			
Variable name	Type	Meaning	Note
CH0_ExceptionOut	BYTE	Channel 0 output status under fault condition	0: Output preset value OFF 1: Maintain previous value 2: Output preset value ON
CH1_ExceptionOut	BYTE	Channel 1 output status under fault condition	
CH2_ExceptionOut	BYTE	Channel 2 output status under fault condition	
CH3_ExceptionOut	BYTE	Channel 3 output status under fault condition	
CH4_ExceptionOut	BYTE	Channel 4 output status under fault condition	
CH5_ExceptionOut	BYTE	Channel 5 output status under fault condition	
CH6_ExceptionOut	BYTE	Channel 6 output status under fault condition	
CH7_ExceptionOut	BYTE	Channel 7 output status under fault condition	
CH8_ExceptionOut	BYTE	Channel 8 output status under fault condition	
CH9_ExceptionOut	BYTE	Channel 9 output status under	

XF-E16Y			
Variable name	Type	Meaning	Note
		fault condition	
CH10_ExceptionOut	BYTE	Channel 10 output status under fault condition	
CH11_ExceptionOut	BYTE	Channel 11 output status under fault condition	
CH12_ExceptionOut	BYTE	Channel 1 output status under fault condition	
CH13_ExceptionOut	BYTE	Channel 12 output status under fault condition	
CH14_ExceptionOut	BYTE	Channel 13 output status under fault condition	
CH15_ExceptionOut	BYTE	Channel 14 output status under fault condition	
CH0-7_Output_LogicLevelL	BYTE	Logic level configuration for channels 0-7	0: Positive logic; 1: Negative logic bit0-bit7 correspond to channels 0-7; bit8-bit15 correspond to channels 8-15
CH8-15_Output_LogicLevelL	BYTE	Logic level configuration for channels 8-15	

6.3.7 Functions and Settings

The host computer does not distinguish between NPN and PNP; the interfaces XF-E16YT and XF-E16PYT are uniformly displayed as XF-E16Y.

■ Channel Template

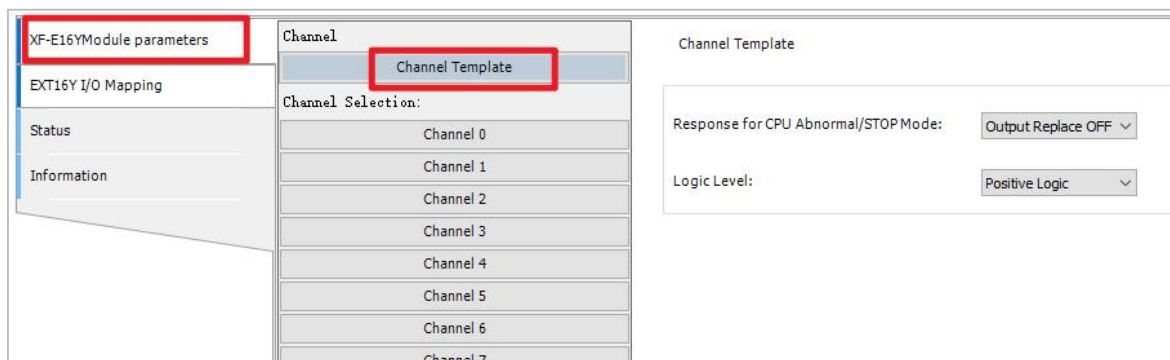

Parameter	Initial Value	Parameter Description
Response of CPU in Fault/STOP Mode	Output Replacement Value OFF	"Output Replacement Value OFF": When the PLC is in STOP mode, the output terminals are in the reset state (for physical terminals; channel logic level is not considered). -"Retain Last Value": When the PLC is in Fault/STOP mode, the output terminals output the last state of the PLC (when switching from RUN to STOP) (for physical terminals; channel logic level is not considered).

Parameter	Initial Value	Parameter Description															
		"Output Replacement Value ON": When the PLC is in Fault/STOP mode, the output terminals are in the set state (for physical terminals; channel logic level is not considered).															
Logic level	Positive Logic	Positive logic: When the terminal in the program is set to ON, the external terminal outputs															
		Negative logic: When the terminal in the program is set to OFF, the external terminal outputs															
		<table border="1"> <thead> <tr> <th>Logic Level Configuration</th> <th>Program in Operation</th> <th>Operation Result</th> </tr> </thead> <tbody> <tr> <td>Positive Logic</td> <td>SET Y0;</td> <td>Y0 is set to ON</td> </tr> <tr> <td>Negative Logic</td> <td>SET Y0;</td> <td>Y0 is set to OFF</td> </tr> <tr> <td>Positive Logic</td> <td>RST Y0;</td> <td>Y0 is set to OFF</td> </tr> <tr> <td>Negative Logic</td> <td>RST Y0;</td> <td>Y0 is set to ON</td> </tr> </tbody> </table>	Logic Level Configuration	Program in Operation	Operation Result	Positive Logic	SET Y0;	Y0 is set to ON	Negative Logic	SET Y0;	Y0 is set to OFF	Positive Logic	RST Y0;	Y0 is set to OFF	Negative Logic	RST Y0;	Y0 is set to ON
		Logic Level Configuration	Program in Operation	Operation Result													
		Positive Logic	SET Y0;	Y0 is set to ON													
Negative Logic	SET Y0;	Y0 is set to OFF															
Positive Logic	RST Y0;	Y0 is set to OFF															
Negative Logic	RST Y0;	Y0 is set to ON															

■ Channel Selection

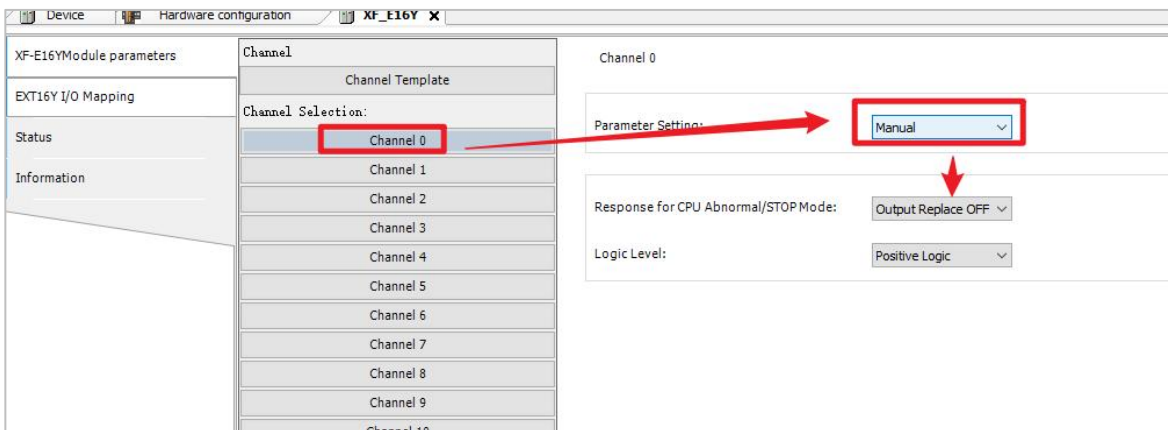
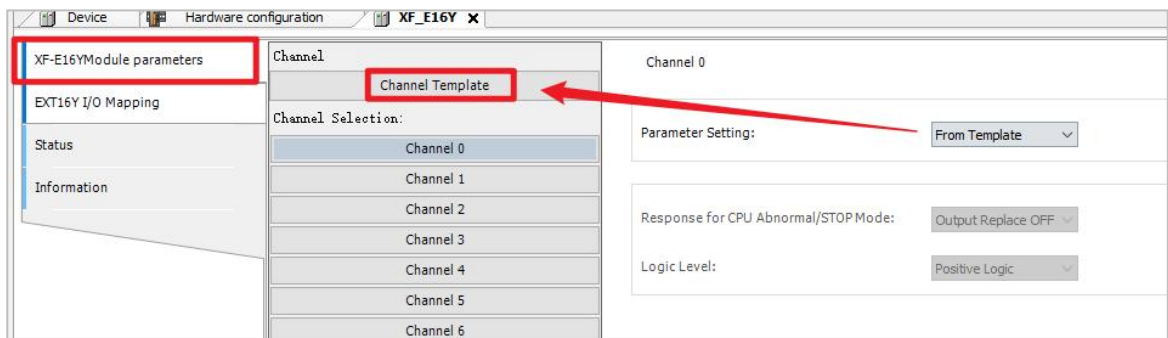

You can set the response to CPU exceptions/STOP mode and the logic level individually for each channel.

Channel Settings	From Template: Use the configuration parameters in the "Channel Template" interface
	Manual: Use the configuration parameters below this interface

6.4 Digital Input/Output Hybrid Unit XF-E8NX8YT

6.4.1 Product Overview

The XF-E8NX8YT series digital I/O hybrid expansion module features 8-channel digital inputs (NPN-compatible) and 8-channel digital outputs (NPN-compatible), compatible with XF/XSF series CPU units and XF series communication couplers.

- 8-channel digital input;
- NPN type input;
- 8-channel digital output;
- NPN type output;
- 12mm width design.

■ Module Version

Hardware version	Firmware version	function
H2.0	V2.0	The basic functions are now officially operational for the first time.

6.4.2 Module View

1) Explanation of each part

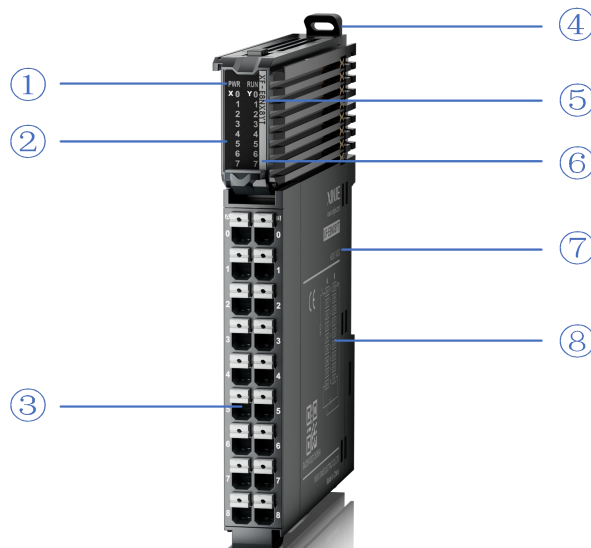

Number	name	Number	name
①	System LED indicator lights	②	Channel LED indicator light
③	disconnectable terminal block	④	fastener
⑤	model indication	⑥	Color code for indicator module type
⑦	Module hardware and Firmware version	⑧	hookup

2) System Indicator Light

System Indicator Light	meaning	
PWR (green)	extinct	The module is not powered on
	Always on	All external power supplies for the module are functioning normally (backplane bus power and external 24V input).
	Flash 1Hz* ¹	The module section is not functioning properly due to a power supply issue.
RUN (green)	Always on	The module is running normally
	Flash 1Hz* ¹	The module encountered a general error in the log
	extinct	The module encountered a critical error in the log
	10Hz* ²	Modeling communication
	Dual Flash* ³	firmware update



- *1: The duty cycle is 50%, and the frequency is 1Hz, with a square wave.
- *2: The duty cycle is 50%, and the frequency is 10Hz, with a square wave.
- *3: As shown below:

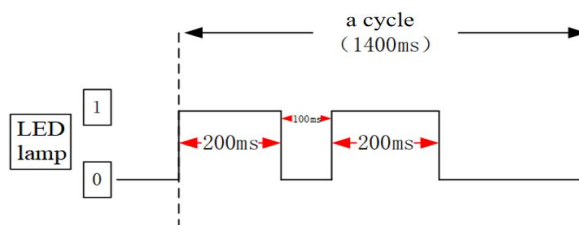

3) Channel indicator light light

model	Channel indicator light		
XF-E8NX8YT	X0-X7	Always on (green)	The corresponding input/output channel has an input/output ON signal
	Y0-Y7	go out	No input/output ON signal for the corresponding input/output channel

4) Color labels

Number	Color		Module type
1		hoar	digital input
2		gray	digital output & digital mixing module
3		wathet	read analogue input
4		mazarine	analog output
5		green	232&485 serial communication
6		rose hermosa	Temperature signal input
7		white	high speed counting
8		purple	pulse output
9		red	repeater power supply

6.4.3 General Specifications

project		specifications
Operation temperature	Maximum temperature	55°C
	Minimum temperature	-20°C
Transportation/Storage Temperature	Maximum temperature	70°C
	Minimum temperature	-40°C
Environmental humidity (including operation/storage)	superior limit	95%
	lower limit	10%
Levels of protection		IP20
Anti-vibration		Complies with IEC61131-2 under intermittent vibration (frequency 5-9Hz, constant amplitude 3.5mm peak displacement) and (frequency 9-150Hz, constant acceleration 1.0g peak acceleration) The continuous shock vibration (5-9Hz, half amplitude 1.75mm displacement) and (9-150Hz, constant acceleration 0.5g, constant frame amplitude) Scan 10 times in each of the X, Y, and Z directions
Shock resistance		Complies with IEC61131-2 standard Impact intensity of 15G (peak) was applied for 11ms on each of three mutually perpendicular axes, with 3 impacts per axis (total 18 impacts).
Operating environment		Non-corrosive gases
Operating altitude		0-2000 meters
Overvoltage class		II: Complies with IEC61131-2
Pollution level		2; Complies with IEC61131-2
Anti-interference EMC		Complies with IEC 61131-2 and IEC 61000-6-4 Type B
Relevant certifications		CE

6.4.4 Technical Specifications

project		specifications
import specifications	Input channel	8
	Input type	NPN
	Rated input voltage	DC24V
	Rated input current	4mA
	Input impedance	5.5KΩ
	ON voltage	15V

project		specifications
	ON Input current	2.5mA
	Enter the OFF voltage	5V
	Enter the OFF current	1mA
	Input derating	The system operates at 55°C with a 50% power reduction (when no more than 4 input points are ON simultaneously), or a 10°C reduction when all input points are ON.
	ON→OFF response time of input resistor (hardware)	0.1ms
	Response time of input resistor from OFF to ON (hardware)	0.1ms
output specifications	outgoing channel	8
	Output type	Transistor (NPN)
	Rated load voltage	DC24V (DC21.6V~26.4V)
	Maximum load current	0.5A/1 point, 2A per module (maximum 2A for 4 points)
	surge current protection	support
	Leakage current at OFF	below 0.1mA
	Output derating	The rated capacity is reduced by 50% when operating at 55°C (with the ON output current not exceeding 1A), or by 10°C when all output points are ON.
	Output ON→OFF response time (hardware)	0.1ms
Output OFF→ON response time (hardware)	0.1ms	
module specifications	Module dissipation	1W (internal backplane) + 1.2W (external input)
	Module weight	80g

6.4.5 Installation & Wiring

6.4.5.1 Appearance dimensions

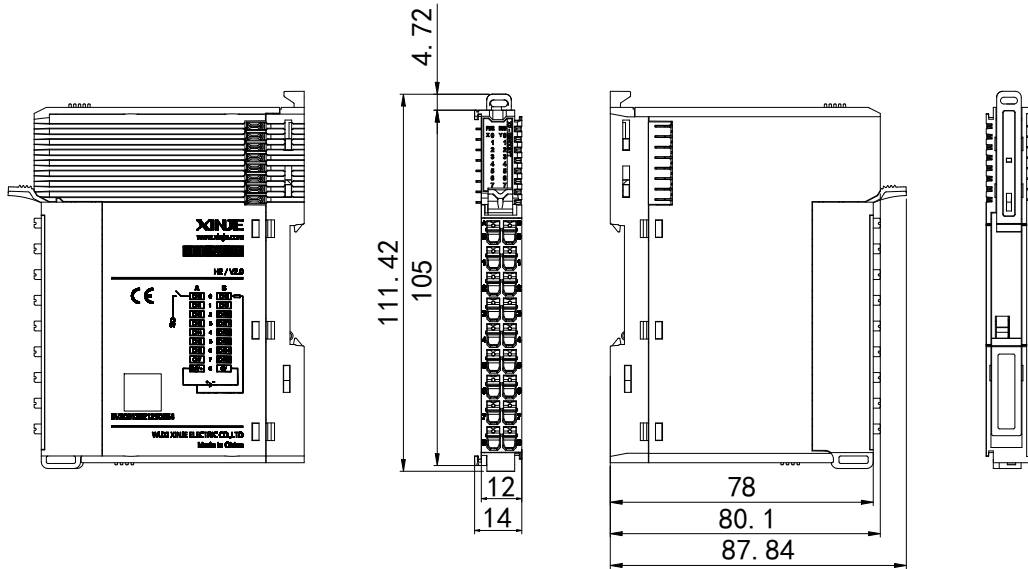

(unit: mm)

6.4.5.2 Terminal Definitions & Wiring

1) Terminal definition

XF-E8NX8YT				
meaning	A terminal	terminal arrangement	B terminal	meaning
CH0	0		0	CH8
CH1	1		1	CH9
CH2	2		2	CH10
CH3	3		3	CH11
CH4	4		4	CH12
CH5	5		5	CH13
CH6	6		6	CH14
CH7	7		7	CH15
24V+	8		8	0V

2) External wiring

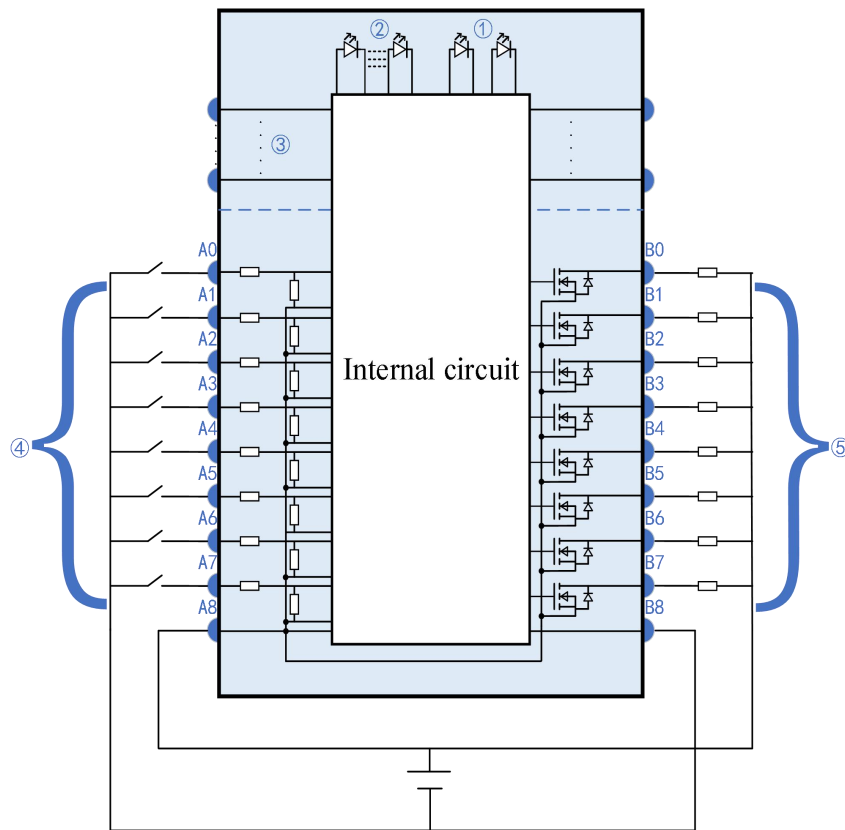

- ① System Indicator Light
- ② Channel indicator light
- ③ backplane bus
- ④ Input channel & wiring light
- ⑤ Output channel & wiring

6.4.5.3 Installation Method

1) Installation requirements

The module is mounted using DIN rails that comply with IEC 60715 standards (35mm wide, 1mm thick). The dimensions are shown in the figure below, with measurements in millimeters.

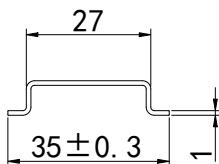

Attention

When the module is installed on a DIN rail not recommended above, the DIN rail latch may fail to lock properly.

2) Installation Steps

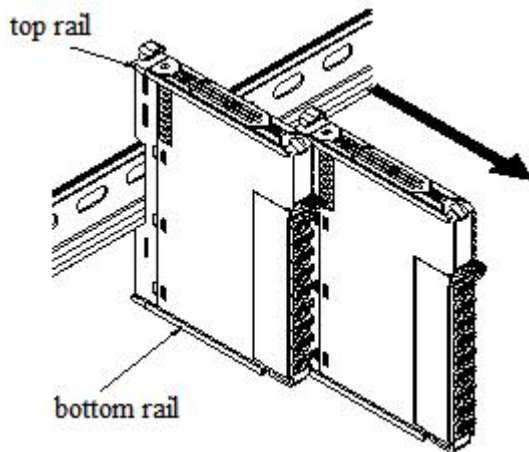

1. The IO modules are assembled by sliding along the top and bottom rails, as shown in the left figure.

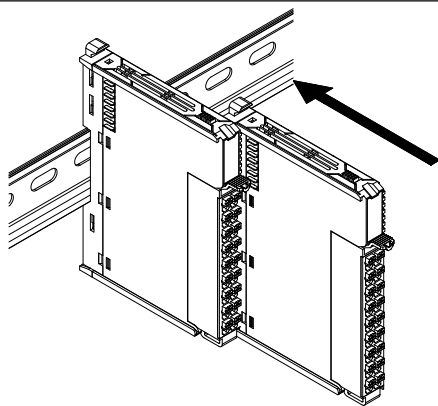

2. The module is mounted on the guide rail. During installation, align the module with the DIN guide rail and press it in the direction indicated by the arrow. A clear click sound will be heard when the module is properly secured, as shown in the left image.

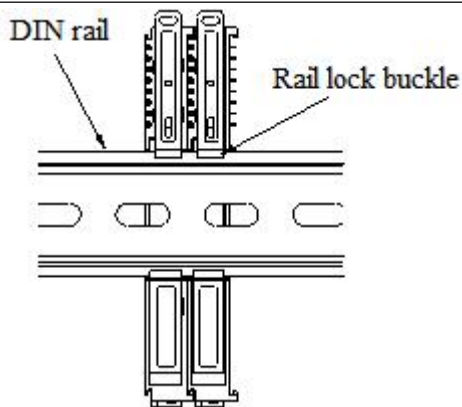

3. After module installation, the latch will automatically lower to lock. If it doesn't move down, press the top of the latch downward to ensure proper installation.

3) Disassembly steps

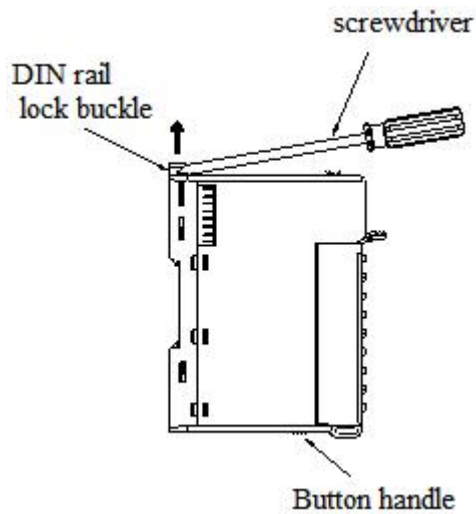

1. Use a screwdriver or similar tool to pry up the guide rail lock, as shown in the left image:

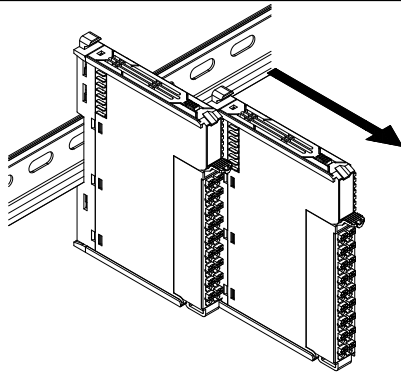

2. Pull the module straight forward from the buckle position (the raised part), then press down the top of the buckle as shown in the left image.

6.4.5.4 Installation Environment

This product supports four installation orientations: horizontal, vertical, top-mounted on electrical cabinets, and bottom-mounted. Horizontal installation is recommended. The cooling system utilizes natural convection. To ensure proper ventilation and heat dissipation while providing sufficient wiring space, a minimum clearance must be maintained around the product, as shown in the figure below.

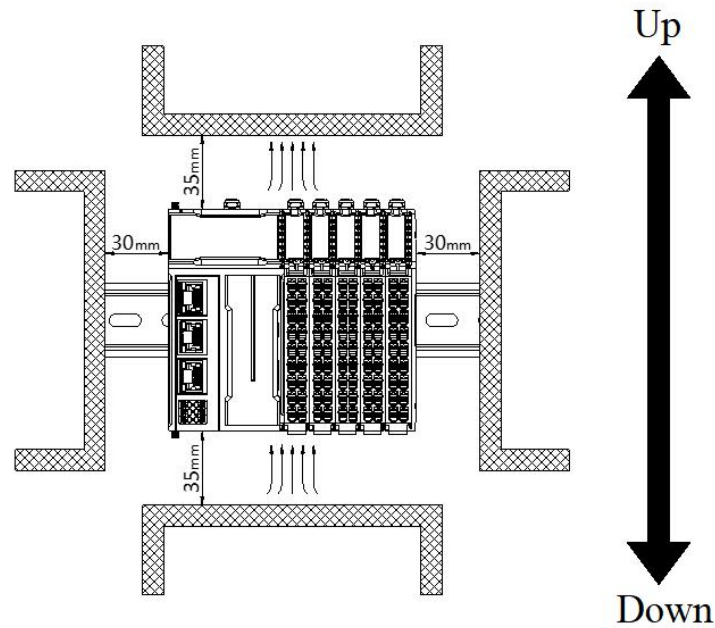

If the product is surrounded by high-temperature heat source equipment (heaters, transformers, large resistors, etc.), maintain a minimum gap of 100mm between the product and such equipment.

6.4.5.5 Equipment Wiring

When wiring the module, the connectors must meet the following requirements:

Suitable wire gauge	
National standard/mm ²	American-Standard /AWG
0.3	22
0.5	20
0.75	18
1.0	18
1.5	16

If using other wire-type terminal lugs, press them onto the stranded wire as shown in the figure below for shape and size requirements.

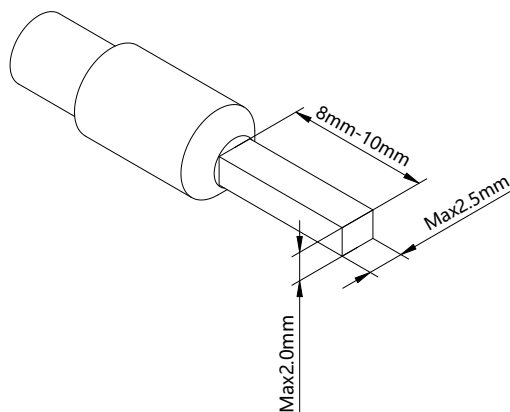

6.4.6 Parameters and Mapping Addresses

Name	Type	Explanation
XF_E8X8Y	Stuct	8-channel input and 8-channel output module
CH0	BOOL	Input value for channel 0
CH1	BOOL	Input value for channel 1
CH2	BOOL	Input value for channel 2
CH3	BOOL	Input value for channel 3
CH4	BOOL	Input value for channel 4
CH5	BOOL	Input value for channel 5
CH6	BOOL	Input value for channel 6
CH7	BOOL	Input value for channel 7
CH8	BOOL	Channel 8 output value
CH9	BOOL	Channel 9 output value
CH10	BOOL	Channel 10 output value
CH11	BOOL	Channel 11 output value
CH12	BOOL	Channel 12 output value
CH13	BOOL	Channel 13 output value
CH14	BOOL	Channel 14 output value
CH15	BOOL	Channel 15 output value
ErrCode_module	WORD	Module-level error code
ErrCode_CH	DWORD	Channel level error code

1) Error code parameter

Module-level error code (ErrCode_module)		
Bit	Meaning	Error level
0	The 24V input power of the module is abnormal.	Critical
2	An internal module error occurred and the user layer cannot fix it	Critical
3	Version mismatch	Critical

2) Configuration parameters

XF-E8NX8YT			
Byte sequence number	Type	Meaning	Remarks
CH0_FilterTime	BYTE	Channel 0 input filter time	
CH1_FilterTime	BYTE	Input filter time for channel 1	0: No filter 11: 9ms 1: 0.25ms 12: 10ms 2: 0.5ms 13: 11ms
CH2_FilterTime	BYTE	Input filter time for channel 2	3: 1ms 14: 12ms 4: 2ms 15: 13ms 5: 3ms 16: 14ms
CH3_FilterTime	BYTE	Channel 3 input filter time	6: 4ms 17: 15ms
CH4_FilterTime	BYTE	Channel 4 input filter time	7: 5ms 18: 20ms
CH5_FilterTime	BYTE	Channel 5 input filter time	8: 6ms 19: 30ms
CH6_FilterTime	BYTE	Channel 6 input filter time	9: 7ms 20: 64ms
CH7_FilterTime	BYTE	Channel 7 input filter time	10: 8ms 21: 128ms
CH8_ExceptionOut	BYTE	Channel 8 output status during abnormal conditions	
CH9_ExceptionOut	BYTE	Output status of channel 9 in abnormal conditions	
CH10_ExceptionOut	BYTE	Output status of channel 10 during abnormal conditions	
CH11_ExceptionOut	BYTE	Output status of channel 11 during abnormal conditions	0: Output replacement value OFF
CH12_ExceptionOut	BYTE	Output status of channel 12 during abnormal conditions	1: Keep the previous value
CH13_ExceptionOut	BYTE	Output status of channel 13 during abnormal conditions	2: Output replacement value ON
CH14_ExceptionOut	BYTE	Output status of channel 14 during abnormal conditions	
CH15_ExceptionOut	BYTE	Output status of channel 15 during abnormal conditions	
CH0-7_Input_Logiclevel	BYTE	Channel 0~7 logic level configuration	0: Positive logic; 1: Negative logic bit0~bit7 correspond to channels 0~7;
CH8-15_Output_LogicLevelL	BYTE	Channel 8-15 logic level configuration	bits 8 to 15 correspond to channels 8 through 15

6.4.7 Functions and Settings

■ Channel Template

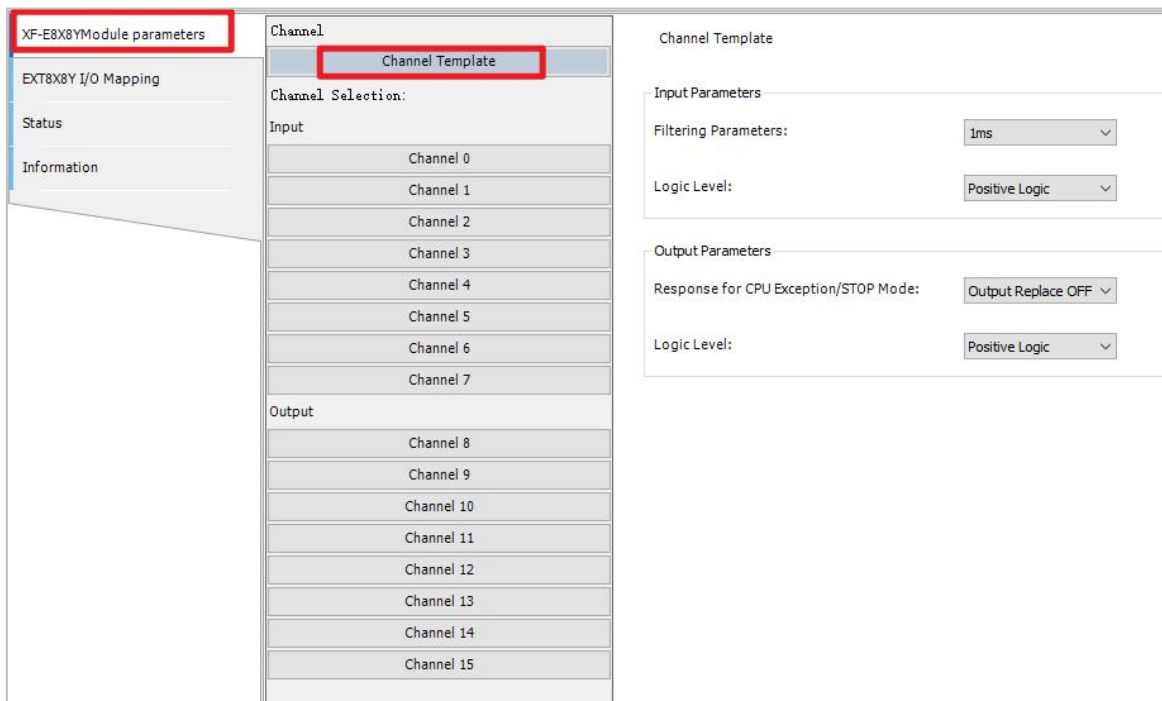

Parameter	Initial Value	Parameter Description																				
Filter Parameter	1ms	-A signal is regarded as valid only when the input terminal receives a signal and the signal duration exceeds the filter time.- Configurable parameters: Available options (displayed in a dropdown list) include: 0ms, 0.25ms, 0.5ms, 1ms, 2ms, 3ms, 4ms, 5ms, 6ms, 7ms, 8ms, 9ms, 10ms, 11ms, 12ms, 13ms, 14ms, 15ms, 20ms, 30ms, 64ms, 128ms																				
Logic level	Positive Logic	Program execution logic after external signal input. <table border="1" style="width: 100%; border-collapse: collapse;"> <thead> <tr> <th>External Input Signal</th> <th>Logic Level Configuration</th> <th>Program in Operation</th> <th>Operation Result</th> </tr> </thead> <tbody> <tr> <td>X0=1</td> <td>Positive Logic</td> <td>-</td> <td>Y0=1</td> </tr> <tr> <td>X0=1</td> <td>Negative Logic</td> <td>LD X0;OUT Y0;</td> <td>Y0=0</td> </tr> <tr> <td>X0=0</td> <td>Positive Logic</td> <td></td> <td>Y0=0</td> </tr> <tr> <td>X0=0</td> <td>Negative Logic</td> <td></td> <td>Y0=1</td> </tr> </tbody> </table>	External Input Signal	Logic Level Configuration	Program in Operation	Operation Result	X0=1	Positive Logic	-	Y0=1	X0=1	Negative Logic	LD X0;OUT Y0;	Y0=0	X0=0	Positive Logic		Y0=0	X0=0	Negative Logic		Y0=1
External Input Signal	Logic Level Configuration	Program in Operation	Operation Result																			
X0=1	Positive Logic	-	Y0=1																			
X0=1	Negative Logic	LD X0;OUT Y0;	Y0=0																			
X0=0	Positive Logic		Y0=0																			
X0=0	Negative Logic		Y0=1																			

Parameter	Initial Value	Parameter Description
Impact on CPU/STOP Mode	Output Replacement OFF	- "Output Replacement Value OFF": When the PLC is in STOP mode, the output terminals are in the reset state (physical terminals; channel logic level is not considered).- "Retain Last Value": When the PLC is in fault/STOP mode, the output terminals maintain the last state (from when the PLC switched from RUN to STOP) (physical terminals; channel logic level is not considered).

Parameter	Initial Value	Parameter Description		
Logic level	Positive Logic	Positive logic: When the terminal in the program is set to ON, the external terminal outputs.		
		Negative logic: When the terminal in the program is set to OFF, the external terminal outputs.		
		Logic Level Configuration	Running Program	Operation Result
		Positive Logic	SET Y0;	Y0 is set to ON
		Negative Logic	SET Y0;	Y0 is set to OFF
Positive Logic	RST Y0;	Y0 is set to OFF		
Negative Logic	RST Y0;	Y0 is set to ON		

■ Channel Selection

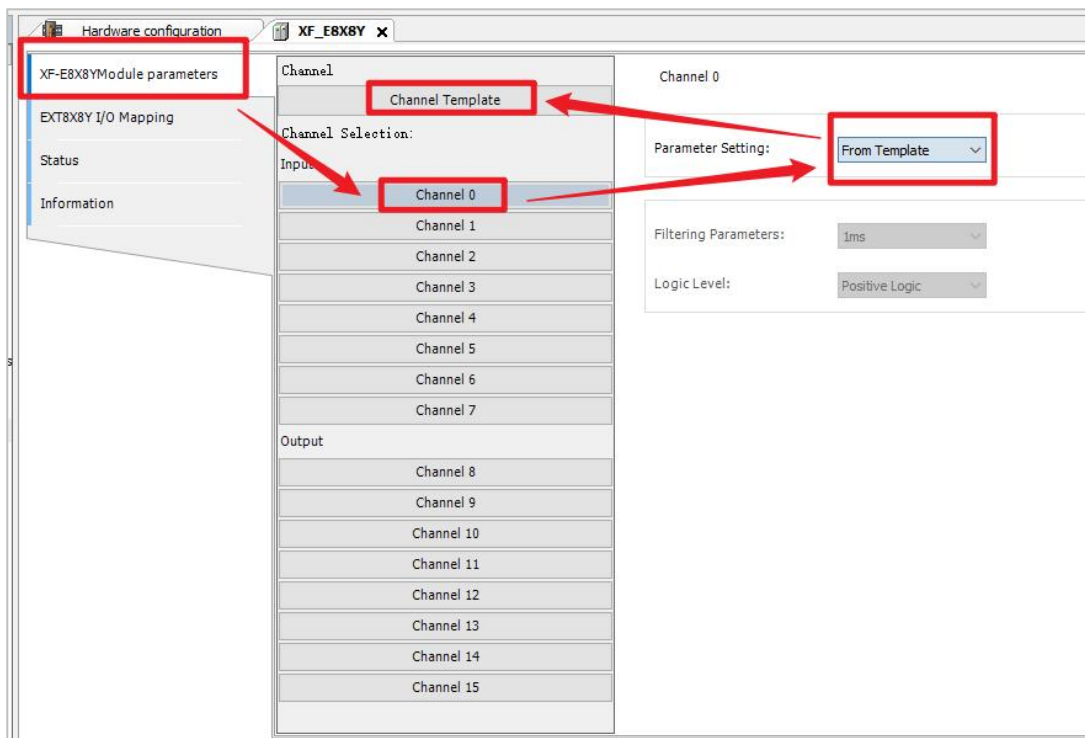
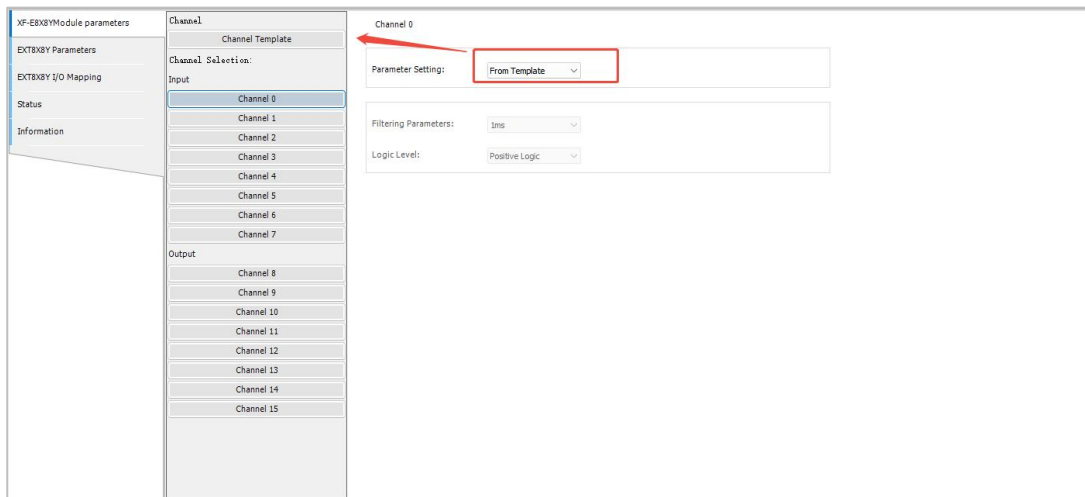

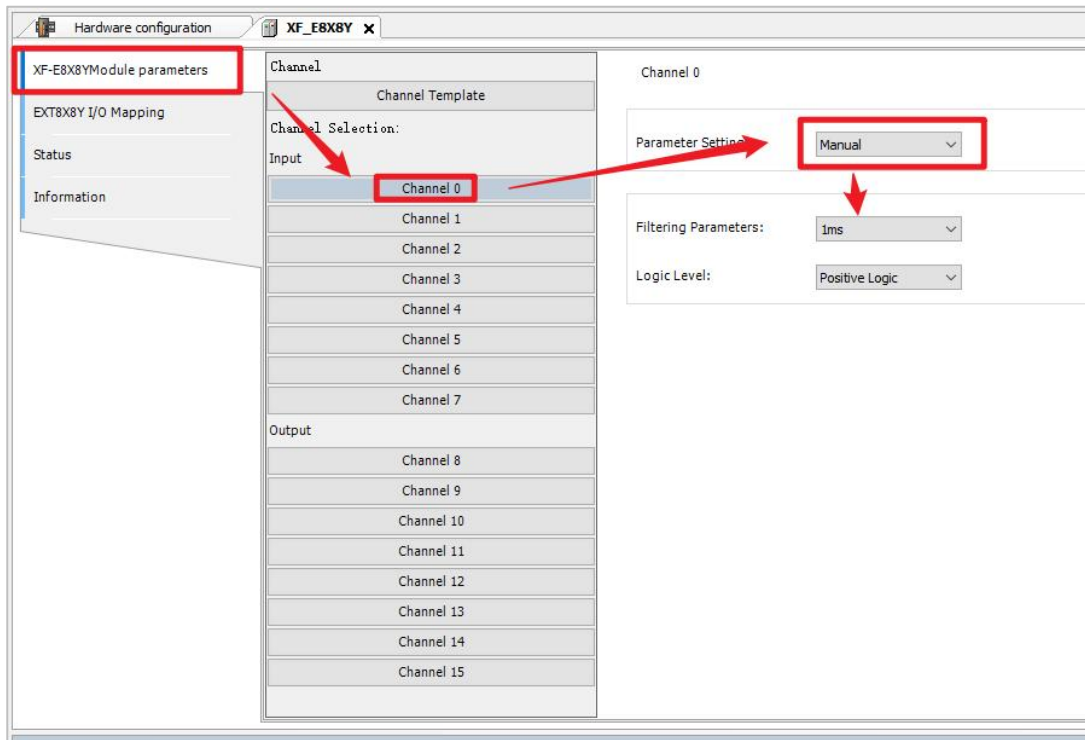

You can set the response to CPU exceptions/STOP mode and the logic level individually for each channel.

Channel Settings	<p>From Template: Use the configuration parameters in the "Channel Template" interface.</p> <p>Manual: Use the configuration parameters below this interface.</p>
------------------	---

6.5 Digital Input Unit XF-E32X

6.5.1 Product Overview

The XF-E32X series digital input expansion module features 32-channel digital inputs supporting NPN and PNP configurations, compatible with XF/XSF series CPU units and XF series communication couplers.

- 32-channel digital input;
- Complies with IEC-61131 Input Standard Type 1;
- NPN and PNP bipolar inputs;
- 24mm width design.

■ Module Version

Hardware version	Firmware version	Function
H2.0	V2.0	The basic functions are now officially operational for the first time.

6.5.2 Module View

1) Explanation of each part

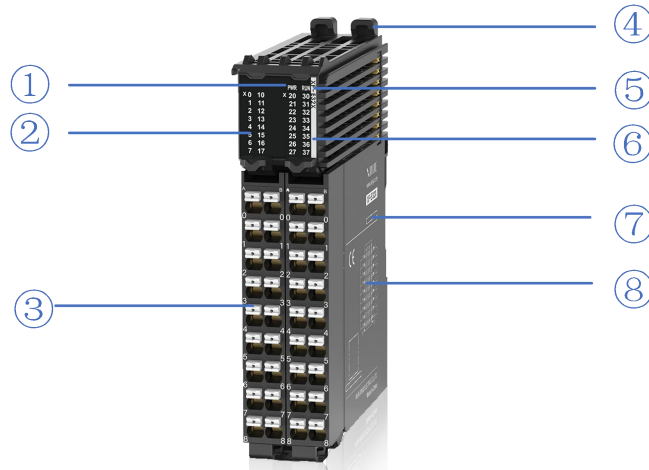

Number	Name	Number	Name
①	System LED indicator lights	②	Channel LED indicator light
③	disconnectable terminal block	④	fastener
⑤	model indication	⑥	Color code for indicator module type
⑦	Module hardware and Firmware version	⑧	hookup

2) System Indicator Light

System Indicator Light	Meaning	
PWR (green)	extinct	Module not powered on (backplane bus)
	Always on	All power supplies for the module are functioning normally (backplane bus power and external 24V input).
	Flash 1Hz*1	Partial module power supply is abnormal and cannot operate normally (external)
RUN (green)	Always on	The module is running normally
	Flash 1Hz*1	The module encountered a general error in the log
	extinct	The module encountered a critical error in the log
	10Hz*2	Modeling communication
	Flash*3	Module heartbeat detection in progress
	Dual Flash*4	firmware update



- *1: The duty cycle is 50%, and the frequency is 1Hz, with a square wave.
- *2: The duty cycle is 50%, and the frequency is 10Hz, with a square wave.
- *3: Indicator light specification: ON:0.2s OFF:1.8s
- *4: The hazard lights are shown below:

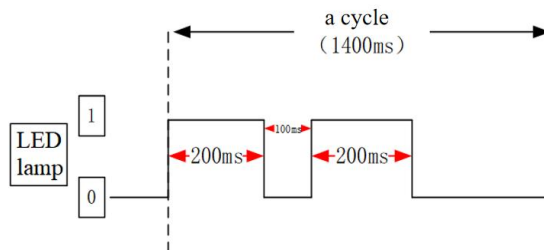

3) Channel indicator light light

Model	Channel indicator light		
XF-E32X	X0-X37	Always on (green)	The corresponding input channel has an ON signal.
		go out	The corresponding input channel has no ON signal

4) Color labels

Number	Color	Module type
1	hoar	digital input
2	gray	digital output & digital mixing module
3	wathet	read analogue input
4	mazarine	analog output
5	green	232&485 serial communication
6	rose hermosa	Temperature signal input

Number	Color	Module type
7	white	high speed counting
8	purple	pulse output
9	red	repeater power supply

6.5.3 General Specifications

Project		Specifications
Operation temperature	Maximum temperature	55°C
	Minimum temperature	-20°C
Transportation/Storage Temperature	Maximum temperature	70°C
	Minimum temperature	-40°C
Environmental humidity (including operation/storage)	superior limit	95%
	lower limit	10%
Levels of protection		IP20
Anti-vibration		Complies with IEC61131-2 under intermittent vibration (frequency 5-9Hz, constant amplitude 3.5mm peak displacement) and (frequency 9-150Hz, constant acceleration 1.0g peak acceleration) The continuous shock vibration (5-9Hz, half amplitude 1.75mm displacement) and (9-150Hz, constant acceleration 0.5g, constant frame amplitude) Scan 10 times in each of the X, Y, and Z directions
Shock resistance		Complies with IEC61131-2 standard Impact intensity of 15G (peak) was applied for 11ms on each of three mutually perpendicular axes, with 3 impacts per axis (total 18 impacts).
Operating environment		Non-corrosive gases
Operating altitude		0-2000 meters
Overvoltage class		II: Complies with IEC61131-2
Pollution level		2; Complies with IEC61131-2
Anti-interference EMC		Complies with IEC 61131-2 and IEC 61000-6-4 Type B
Relevant certifications		UL,CE

6.5.4 Technical Specifications

project	specifications
Input points	32
Rated input voltage	DC24V
Rated input current	4mA
Input impedance	5.5KΩ
ON voltage	15V
ON Input current	2.5mA
Enter the OFF voltage	5V
Enter the OFF current	1mA
ON→OFF response time of input resistor (hardware)	0.1ms
Response time of input resistor from OFF to ON (hardware)	0.1ms
Input derating	The system operates at 55°C with a 50% power reduction (when no more than 16 input points are ON simultaneously), or a 10°C reduction when all input points are ON.
Public mode	1 public endpoint at 16:00
Mode of connection	See the external terminal connection diagram
Module dissipation	0.8W (internal backplane) + 3.2W (external input)
Module weight	128g

6.5.5 Installation & Wiring

6.5.5.1 Appearance dimensions

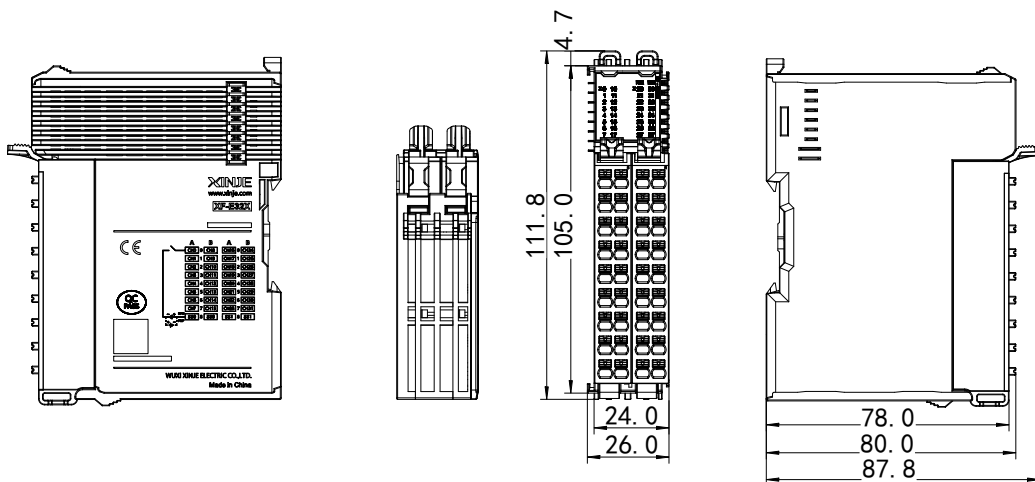

(unit: mm)

6.5.5.2 Terminal Definitions & Wiring

1) Terminal definition

XF-E32X								
meaning	A terminal (left)	meaning	ColumnB terminal (left)	terminal arrangement	meaning	Column A terminal (right)	meaning	ColumnB terminal (right)
CH0	0	CH8	0		CH16	0	CH24	0
CH1	1	CH9	1		CH17	1	CH25	1
CH2	2	CH10	2		CH18	2	CH26	2
CH3	3	CH11	3		CH19	3	CH27	3
CH4	4	CH12	4		CH20	4	CH28	4
CH5	5	CH13	5		CH21	5	CH29	5
CH6	6	CH14	6		CH22	6	CH30	6
CH7	7	CH15	7		CH23	7	CH31	7
SS0	8	SS0	8		SS1	8	SS1	8



Since SS0 and SS1 are internally short-circuited, each module's left and right input columns can be configured as either NPN or PNP.

2) External wiring (e.g., CH0-CH15; CH16-CH31 follows the same principle)

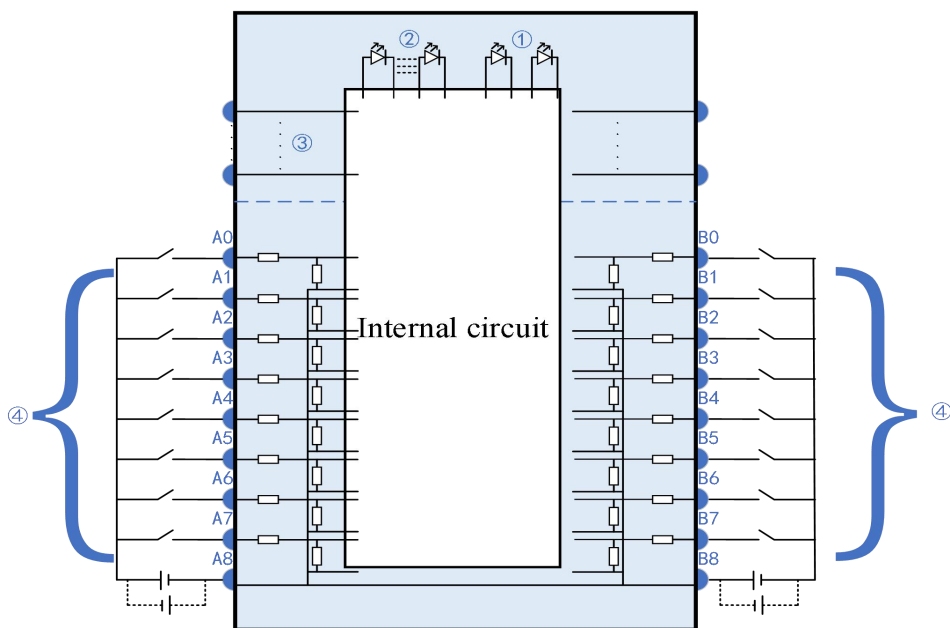

① System Indicator Light ② Channel indicator light light ③ backplane bus ④ Input channel & wiring

6.5.5.3 Installation Method

1) Installation requirements

The module is mounted using DIN rails that comply with IEC 60715 standards (35mm wide, 1mm thick). The dimensions are shown in the figure below, with measurements in millimeters.

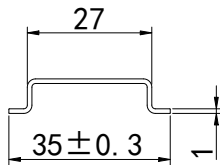

Attention

When the module is installed on a DIN rail not recommended above, the DIN rail latch may fail to lock properly.

2) Installation Steps

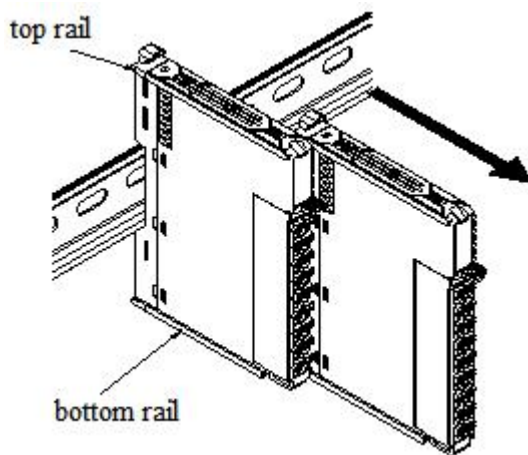

1. The IO modules are assembled by sliding along the top and bottom rails, as shown in the left figure.

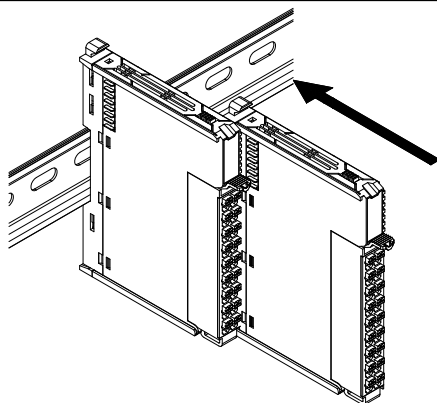

2. The module is mounted on the guide rail. During installation, align the module with the DIN guide rail and press it in the direction indicated by the arrow. A clear click sound will be heard when the module is properly secured, as shown in the left image.

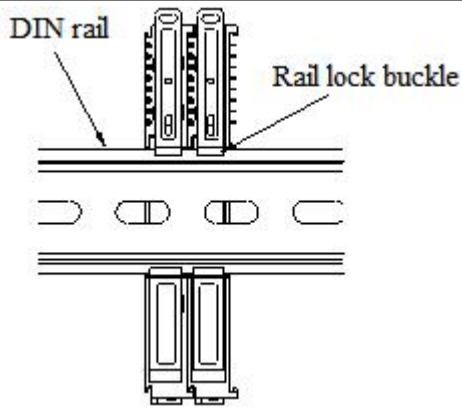

3. After module installation, the latch will automatically lower to lock. If it doesn't move down, press the top of the latch downward to ensure proper installation.

3) Disassembly steps

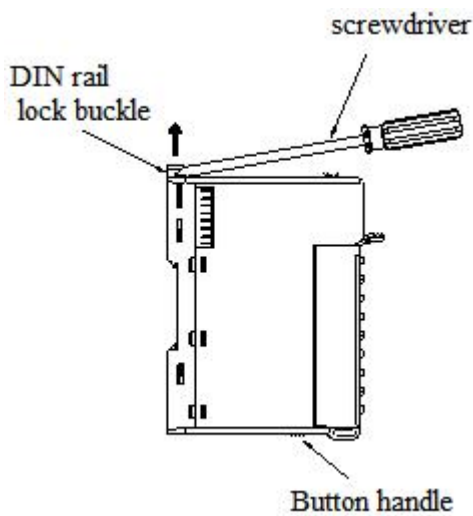

1. Use a screwdriver or similar tool to pry up the guide rail lock, as shown in the left image:

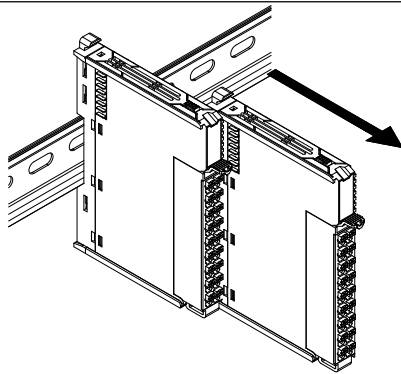

2. Pull the module straight forward from the buckle position (the raised part), then press down the top of the buckle as shown in the left image.

6.5.5.4 Installation Environment

This product supports four installation orientations: horizontal, vertical, top-mounted on electrical cabinets, and bottom-mounted. Horizontal installation is recommended. The cooling system utilizes natural convection. To ensure proper ventilation and heat dissipation while providing sufficient wiring space, a minimum clearance must be maintained around the product, as shown in the figure below.

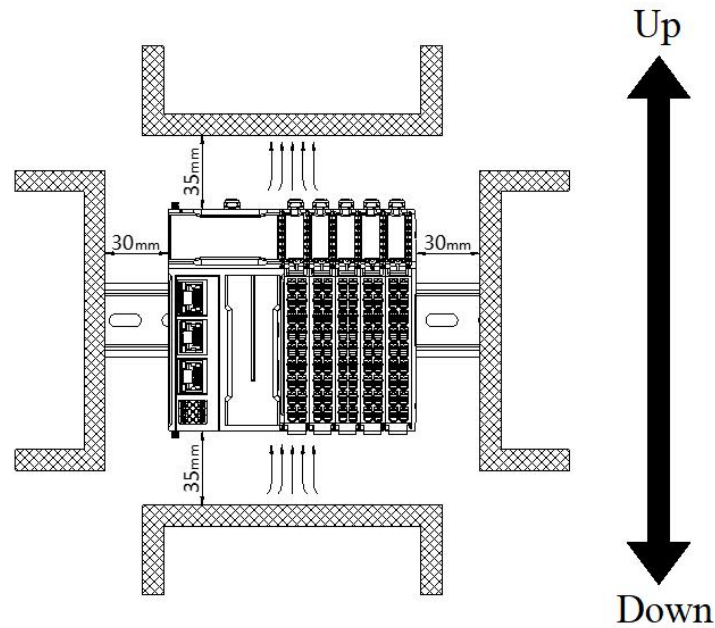

If the product is surrounded by high-temperature heat source equipment (heaters, transformers, large resistors, etc.), maintain a minimum gap of 100mm between the product and such equipment.

6.5.5.5 Equipment Wiring

When wiring the module, the connectors must meet the following requirements:

Suitable wire gauge	
National standard/mm ²	American-Standard /AWG
0.3	22
0.5	20
0.75	18
1.0	18
1.5	16

If using other wire-type terminal lugs, press them onto the stranded wire as shown in the figure below for shape and size requirements.

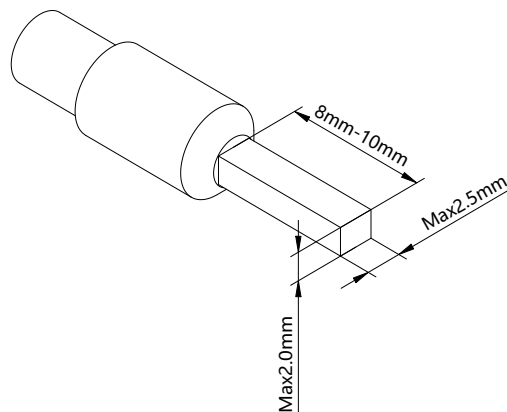

6.5.6 Parameters and Mapping Addresses

Name	Type	Explanation
XF_E32X	Stuct	32-channel input module
CH0	BOOL	Input value for channel 0
CH1	BOOL	Input value for channel 1
CH2	BOOL	Input value for channel 2
CH3	BOOL	Input value for channel 3
CH4	BOOL	Input value for channel 4
CH5	BOOL	Input value for channel 5
CH6	BOOL	Input value for channel 6
CH7	BOOL	Input value for channel 7
CH8	BOOL	Channel 8 input value
CH9	BOOL	Channel 9 input value
CH10	BOOL	Input value for channel 10
CH11	BOOL	Input value for channel 11
CH12	BOOL	Input value for channel 12
CH13	BOOL	Input value for channel 13
CH14	BOOL	Input value for channel 14
CH15	BOOL	Input value for channel 15
CH16	BOOL	Input value for channel 16
CH17	BOOL	Input value for channel 17
CH18	BOOL	Input value for channel 18
CH19	BOOL	Input value for channel 19
CH20	BOOL	Input value for channel 20
CH21	BOOL	Input value for channel 21
CH22	BOOL	Input value for channel 22
CH23	BOOL	Input value for channel 23
CH24	BOOL	Input value for channel 24

Name	Type	Explanation
XF_E32X	Stuct	32-channel input module
CH25	BOOL	Input value for channel 25
CH26	BOOL	Input value for channel 26
CH27	BOOL	Input value for channel 27
CH28	BOOL	Input value for channel 28
CH29	BOOL	Input value for channel 29
CH30	BOOL	Input value for channel 30
CH31	BOOL	Input value for channel 31
ErrCode_module	WORD	Module-level error code
ErrCode_CH	DWORD	Channel level error code

■ Error code parameter

Module-level error code (ErrCode_module)		
Bit	Meaning	Error level
0	The 24V input power of the module is abnormal.	Medium
1	Incorrect module parameter assignment	Critical
2	An internal module error occurred and the user layer cannot fix it	Critical
3	Version mismatch	Critical



Channel level error codes are reserved and not defined.

6.5.7 Functions and Settings

■ Channel Template

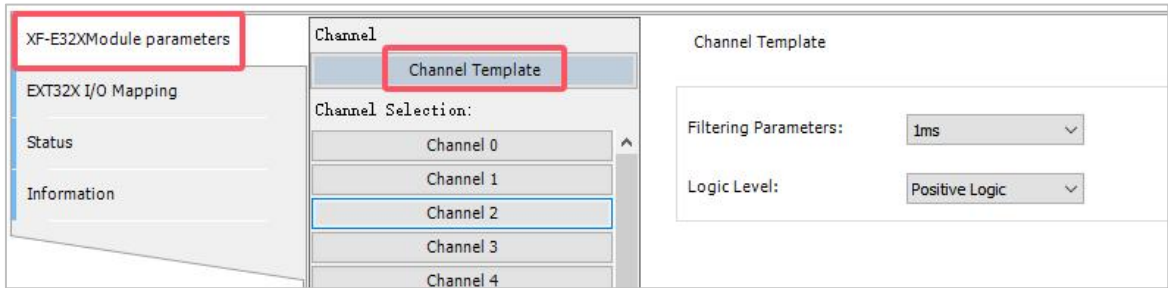

Parameter	Initial value	Parameter declaration																	
filter parameter	1ms	<p>When the signal is on the input terminal and the signal duration is longer than the filter time, it is regarded as a valid signal.</p> <p>Settable parameters: The following drop-down list shows the settable parameters: 0ms, 0.25ms, 0.5ms, 1ms, 2ms, 3ms, 4ms, 5ms, 6ms, 7ms, 8ms, 9ms, 10ms, 11ms, 12ms, 13ms, 14ms, 15ms, 20ms, 30ms, 64ms, 128ms</p>																	
logic level	positive logic	<p>The logic of program execution after external signal input.</p> <table border="1"> <thead> <tr> <th>External input signal</th> <th>Logic level configuration</th> <th>Program Execution</th> <th>Result of calculation</th> </tr> </thead> <tbody> <tr> <td>X0=1</td> <td>positive logic</td> <td rowspan="4">LD X0; OUT Y0;</td> <td>Y0=1</td> </tr> <tr> <td>X0=1</td> <td>negative logic</td> <td>Y0=0</td> </tr> <tr> <td>X0=0</td> <td>positive logic</td> <td>Y0=0</td> </tr> <tr> <td>X0=0</td> <td>negative logic</td> <td>Y0=1</td> </tr> </tbody> </table>	External input signal	Logic level configuration	Program Execution	Result of calculation	X0=1	positive logic	LD X0; OUT Y0;	Y0=1	X0=1	negative logic	Y0=0	X0=0	positive logic	Y0=0	X0=0	negative logic	Y0=1
External input signal	Logic level configuration	Program Execution	Result of calculation																
X0=1	positive logic	LD X0; OUT Y0;	Y0=1																
X0=1	negative logic		Y0=0																
X0=0	positive logic		Y0=0																
X0=0	negative logic		Y0=1																

■ channel selection

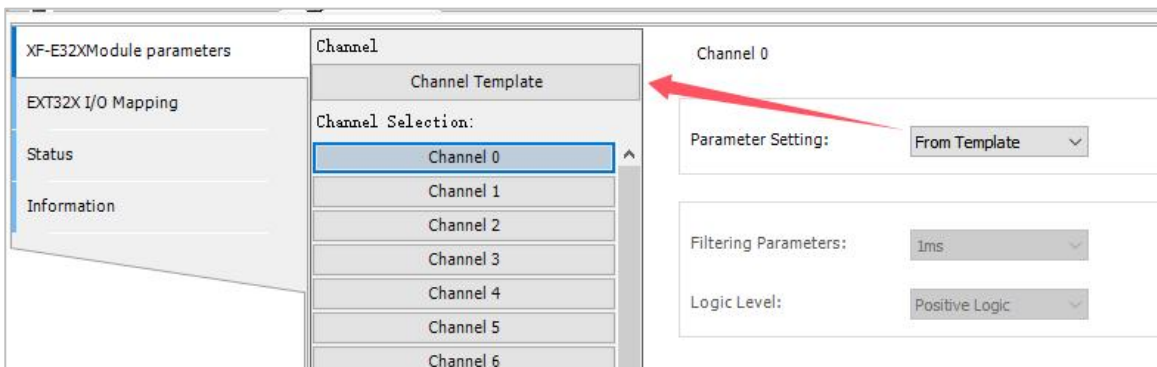

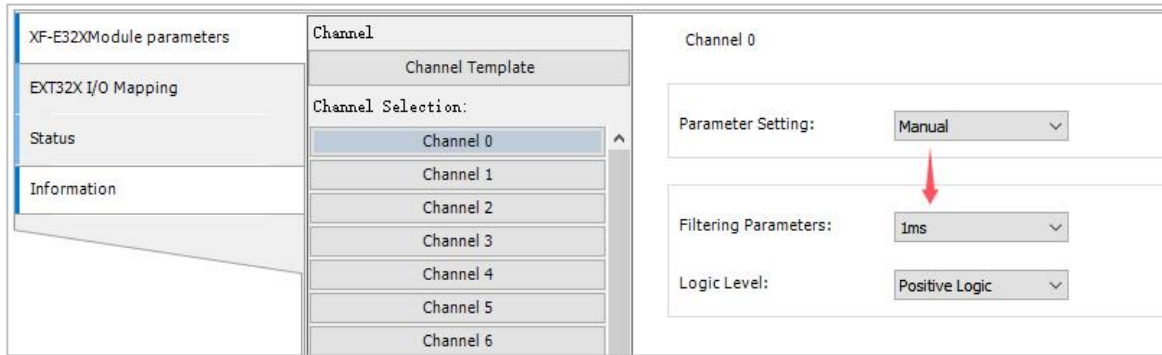

Filter parameters and logic levels can be set individually for each channel.

Channel Settings	From template: Use the configuration parameters in the "Channel Template" interface Manual: Use the configuration parameters at the bottom of this interface
-------------------------	---

6.6 Digital Output Unit XF-E32YT

6.6.1 Product Overview

The XF-E32YT series digital output expansion module features 32-channel digital outputs, compatible with XF/XSF series CPU units and XF series communication couplers.

- 32-channel digital output;
- NPN output;
- 24mm width design.

■ Module Version

Hardware version	Firmware version	Function
H2.0	V2.0	The basic functions are now officially operational for the first time.

6.6.2 Module View

1) Explanation of each part

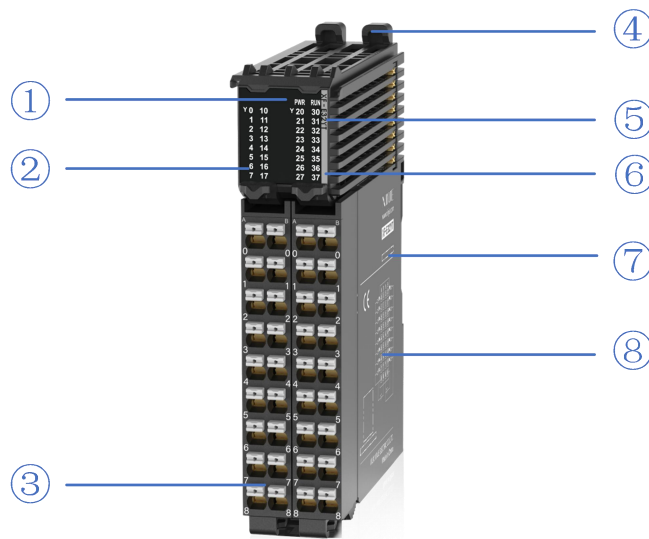

Number	Name	Number	Name
①	System LED indicator lights	②	Channel LED indicator light
③	disconnectable terminal block	④	fastener
⑤	model indication	⑥	Color code for indicator module type
⑦	Module hardware and Firmware version	⑧	hookup

2) System Indicator Light

System Indicator Light	,Meaning	
PWR (green)	extinct	Module not powered on (backplane bus)
	Always on	All power supplies for the module are functioning normally (backplane bus power and external 24V input).
	Flash 1Hz*1	Partial module power supply is abnormal and cannot operate normally (external)
RUN (green)	Always on	The module is running normally
	Flash 1Hz*1	The module encountered a general error in the log
	extinct	The module encountered a critical error in the log
	10Hz*2	Modeling communication
	Flash*3	Module heartbeat detection in progress
	Dual Flash*4	firmware update



- *1: The duty cycle is 50%, and the frequency is 1Hz, with a square wave.
- *2: The duty cycle is 50%, and the frequency is 10Hz, with a square wave.
- *3: Indicator light specification: ON:0.2s OFF:1.8s
- *4: The hazard lights are shown below:

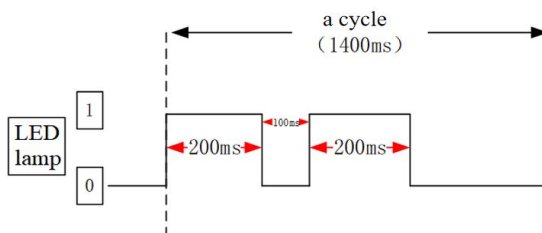

3) Channel indicator light light

model	Channel indicator light		
XF-E32YT	Y0-Y37	Always on (green)	The corresponding output channel has an ON signal.
		go out	The corresponding output channel has no ON signal

4) Color labels

Number	Color	Module type
1	hoar	digital input
2	gray	digital output & digital mixing module
3	wathet	read analogue input
4	mazarine	analog output
5	green	232&485 serial communication
6	rose hermosa	Temperature signal input

Number	Color		Module type
7		white	high speed counting
8		purple	pulse output
9		red	repeater power supply

6.6.3 General Specifications

project		specifications
Operation temperature	Maximum temperature	55°C
	Minimum temperature	-20°C
Transportation/Storage Temperature	Maximum temperature	70°C
	Minimum temperature	-40°C
Environmental humidity (including operation/storage)	superior limit	95%
	lower limit	10%
Levels of protection		IP20
Anti-vibration		Complies with IEC61131-2 under intermittent vibration (frequency 5-9Hz, constant amplitude 3.5mm peak displacement) and (frequency 9-150Hz, constant acceleration 1.0g peak acceleration) The continuous shock vibration (5-9Hz, half amplitude 1.75mm displacement) and (9-150Hz, constant acceleration 0.5g, constant frame amplitude) Scan 10 times in each of the X, Y, and Z directions
Shock resistance		Complies with IEC61131-2 standard Impact intensity of 15G (peak) was applied for 11ms on each of three mutually perpendicular axes, with 3 impacts per axis (total 18 impacts).
Operating environment		Non-corrosive gases
Operating altitude		0-2000 meters
Overvoltage class		II: Complies with IEC61131-2
Pollution level		2; Complies with IEC61131-2
Anti-interference EMC		Complies with IEC 61131-2 and IEC 61000-6-4 Type B
Relevant certifications		UL,CE

6.6.4 Technical Specifications

Project	Specifications
Model	XF-E32YT
Output points	32
Rated load voltage	DC24V(DC21.6V~26.4V)
Maximum load current	0.5A per point, 8A per module (maximum 2A for 4 points)
surge current protection	support
Leakage current at OFF	below 0.1mA
Output ON→OFF response time (hardware)	0.1ms
Output OFF→ON response time (hardware)	0.1ms
Output derating	The rated capacity is reduced by 50% when operating at 55°C (with the ON output current not exceeding 4A), or by 10°C when all output points are ON.
Public mode	1 public endpoint at 16:00
Output protection	Supports short-circuit and overload protection
Module dissipation	1.2W (internal backplane) + 0.6W (external input)
Module weight	137g

6.6.5 Installation & Wiring

6.6.5.1 Appearance dimensions

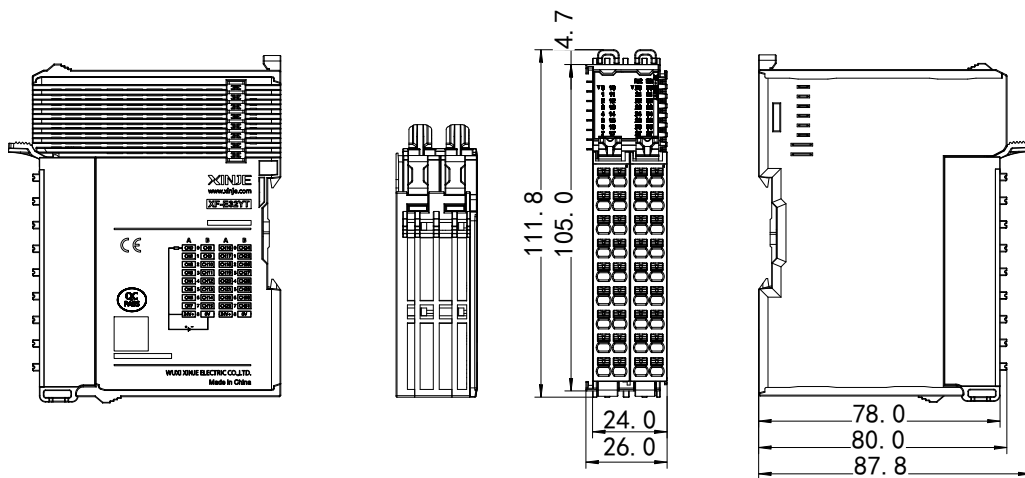

(unit: mm)

6.6.5.2 Terminal Definitions & Wiring

1) Terminal definition

XF-E32YT								
Meaning	A Terminal (left)	Meaning	Column B terminal (left)	Terminal layout	Meaning	Column A terminal (right)	Meaning	Column B terminal (right)
CH0	0	CH8	0		CH16	0	CH24	0
CH1	1	CH9	1		CH17	1	CH25	1
CH2	2	CH10	2		CH18	2	CH26	2
CH3	3	CH11	3		CH19	3	CH27	3
CH4	4	CH12	4		CH20	4	CH28	4
CH5	5	CH13	5		CH21	5	CH29	5
CH6	6	CH14	6		CH22	6	CH30	6
CH7	7	CH15	7		CH23	7	CH31	7
24V+	8	0V	8	24V+	8	0V	8	



The two 0V circuits are internally short-circuited, while the two 24V circuits are isolated internally.

2) External wiring (e.g., CH0-CH15; CH16-CH31 follows the same principle)

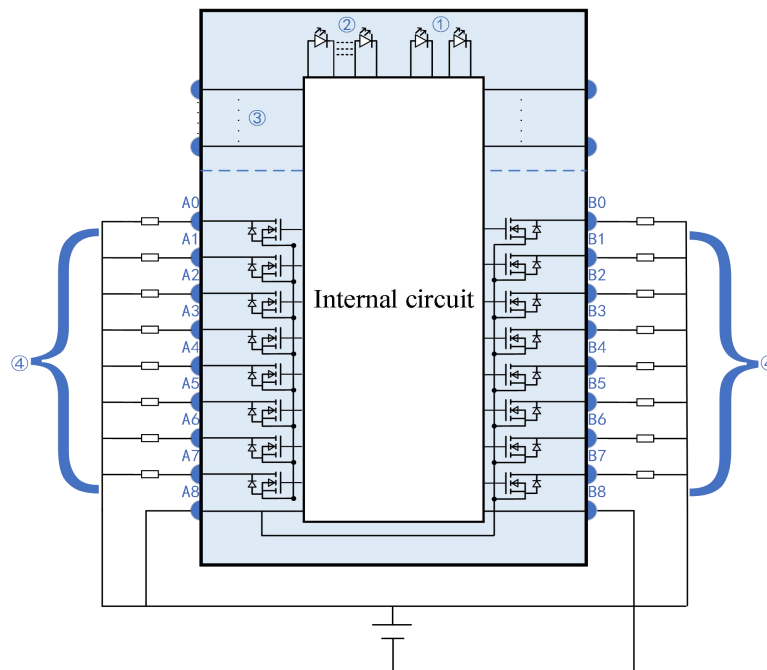

- ① System Indicator Light
- ② Channel indicator light
- ③ backplane bus
- ④ Output channel & wiring

6.6.5.3 Installation Method

1) Installation requirements

The module is mounted using DIN rails that comply with IEC 60715 standards (35mm wide, 1mm thick). The dimensions are shown in the figure below, with measurements in millimeters.

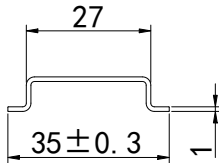

Attention

When the module is installed on a DIN rail not recommended above, the DIN rail latch may fail to lock properly.

2) Installation Steps

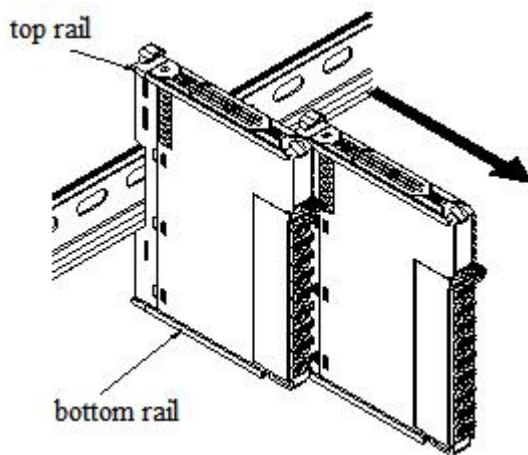

1. The IO modules are assembled by sliding along the top and bottom rails, as shown in the left figure.

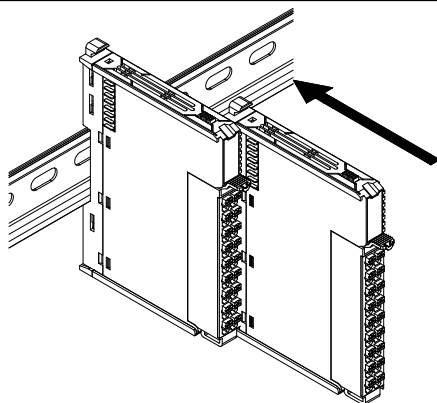

2. The module is mounted on the guide rail. During installation, align the module with the DIN guide rail and press it in the direction indicated by the arrow. A clear click sound will be heard when the module is properly secured, as shown in the left image.

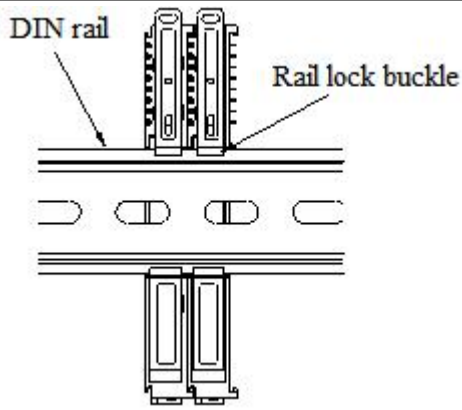

3. After module installation, the latch will automatically lower to lock. If it doesn't move down, press the top of the latch downward to ensure proper installation.

3) Disassembly steps

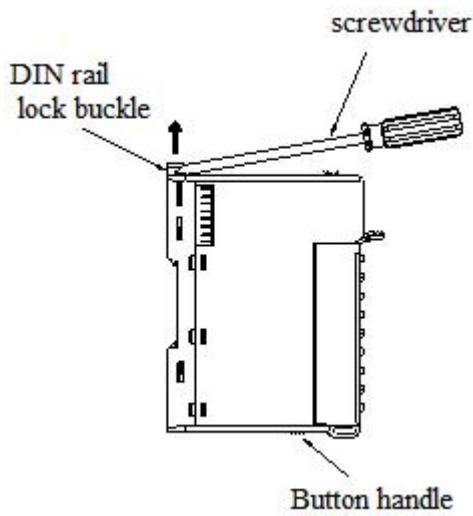

1. Use a screwdriver or similar tool to pry up the guide rail lock, as shown in the left image:

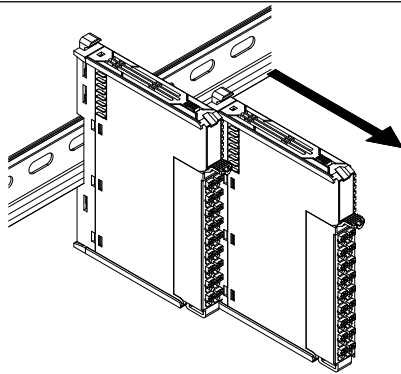

2. Pull the module straight forward from the buckle position (the raised part), then press down the top of the buckle as shown in the left image.

6.6.5.4 Installation Environment

This product supports four installation orientations: horizontal, vertical, top-mounted on electrical cabinets, and bottom-mounted. Horizontal installation is recommended. The cooling system utilizes natural convection. To ensure proper ventilation and heat dissipation while providing sufficient wiring space, a minimum clearance must be maintained around the product, as shown in the figure below.

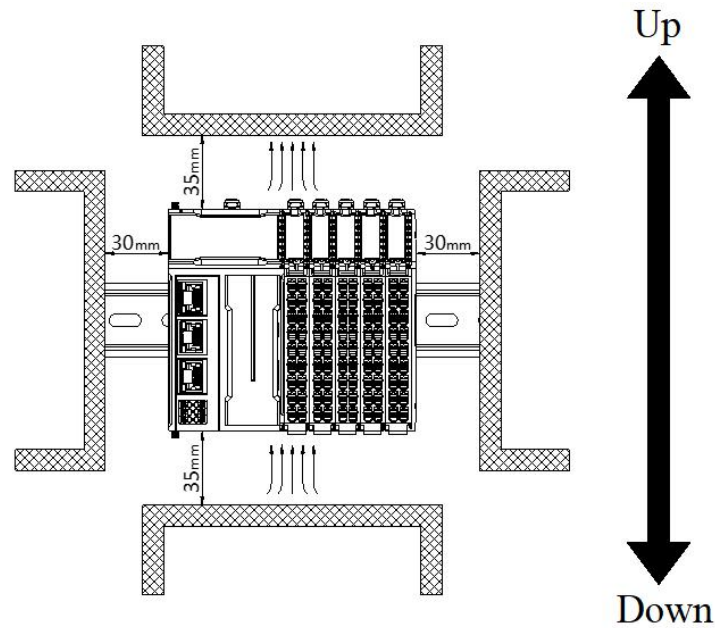

If the product is surrounded by high-temperature heat source equipment (heaters, transformers, large resistors, etc.), maintain a minimum gap of 100mm between the product and such equipment.

6.6.5.5 Equipment Wiring

When wiring the module, the connectors must meet the following requirements:

Suitable wire gauge	
National standard/mm ²	American-Standard /AWG
0.3	22
0.5	20
0.75	18
1.0	18
1.5	16

If using other wire-type terminal lugs, press them onto the stranded wire as shown in the figure below for shape and size requirements.

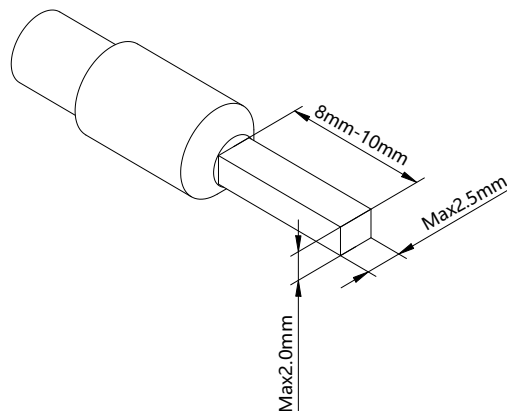

6.6.6 Parameters and Mapping Addresses

Name	Type	Explanation
XF_E32YT	Stuct	32-channel output module
CH0	BOOL	Channel 0 output value
CH1	BOOL	Channel 1 output value
CH2	BOOL	Channel 2 output value
CH3	BOOL	Channel 3 output value
CH4	BOOL	Channel 4 output value
CH5	BOOL	Channel 5 output value
CH6	BOOL	Channel 6 output value
CH7	BOOL	Channel 7 output value
CH8	BOOL	Channel 8 output value
CH9	BOOL	Channel 9 output value
CH10	BOOL	Channel 10 output value
CH11	BOOL	Channel 11 output value
CH12	BOOL	Channel 12 output value
CH13	BOOL	Channel 13 output value
CH14	BOOL	Channel 14 output value
CH15	BOOL	Channel 15 output value
CH16	BOOL	Channel 16 output value
CH17	BOOL	Channel 17 output value
CH18	BOOL	Channel 18 output value
CH19	BOOL	Channel 19 output value
CH20	BOOL	Channel 20 output value
CH21	BOOL	Channel 21 output value
CH22	BOOL	Channel 22 output value
CH23	BOOL	Channel 23 output value
CH24	BOOL	Channel 24 output value

Name	Type	Explanation
XF_E32YT	Stuct	32-channel output module
CH25	BOOL	Channel 25 output value
CH26	BOOL	Channel 26 output value
CH27	BOOL	Channel 27 output value
CH28	BOOL	Channel 28 output value
CH29	BOOL	Channel 29 output value
CH30	BOOL	Channel 30 output value
CH31	BOOL	Channel 31 output value
ErrCode_module	WORD	Module-level error code
ErrCode_CH	DWORD	Channel level error code

■ Error code parameter

Module-level error code (ErrCode_module)		
Bit	meaning	Error level
0	The 24V input power of the module is abnormal.	Medium
1	Incorrect module parameter assignment	Critical
2	An internal module error occurred and the user layer cannot fix it	Critical
3	Version mismatch	Critical



Channel level error codes are reserved and not defined.

6.6.7 Functions and Settings

■ Channel Template

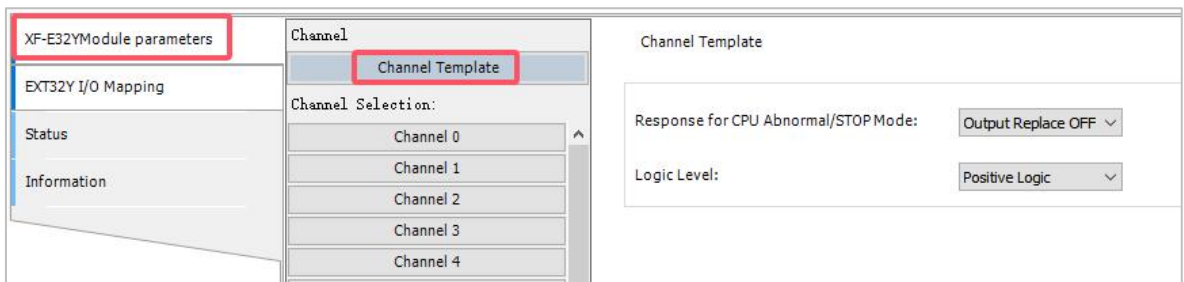

parameter	initial value	parameter declaration															
Response to CPU Abnormal/STOP Mode	Replace OFF	<p>"Output Replacement Value OFF" When the PLC is in STOP mode, the output terminals are reset (physical terminals, channel logic levels irrelevant)</p> <p>"Maintain previous value" When the PLC is in abnormal/STOP mode, the output terminal displays the final state from RUN to STOP (physical terminal, channel logic level irrelevant)</p> <p>"ON Output Replacement Value" When the PLC is in abnormal/STOP mode, the output terminals are set (physical terminals, channel logic levels irrelevant)</p>															
logic level	positive logic	<p>Positive logic: When the program terminal is ON, the external terminal outputs</p> <p>Negative logic: When the program terminal is set to OFF, the external terminal outputs</p> <table border="1"> <thead> <tr> <th>Logic Level Configuration</th> <th>Running Program</th> <th>Operation Result</th> </tr> </thead> <tbody> <tr> <td>Positive Logic</td> <td>SET Y0;</td> <td>Y0 is set to ON</td> </tr> <tr> <td>Negative Logic</td> <td>SET Y0;</td> <td>Y0 is set to OFF</td> </tr> <tr> <td>Positive Logic</td> <td>RST Y0;</td> <td>Y0 is set to OFF</td> </tr> <tr> <td>Negative Logic</td> <td>RST Y0;</td> <td>Y0 is set to ON</td> </tr> </tbody> </table>	Logic Level Configuration	Running Program	Operation Result	Positive Logic	SET Y0;	Y0 is set to ON	Negative Logic	SET Y0;	Y0 is set to OFF	Positive Logic	RST Y0;	Y0 is set to OFF	Negative Logic	RST Y0;	Y0 is set to ON
Logic Level Configuration	Running Program	Operation Result															
Positive Logic	SET Y0;	Y0 is set to ON															
Negative Logic	SET Y0;	Y0 is set to OFF															
Positive Logic	RST Y0;	Y0 is set to OFF															
Negative Logic	RST Y0;	Y0 is set to ON															

■ channel selection

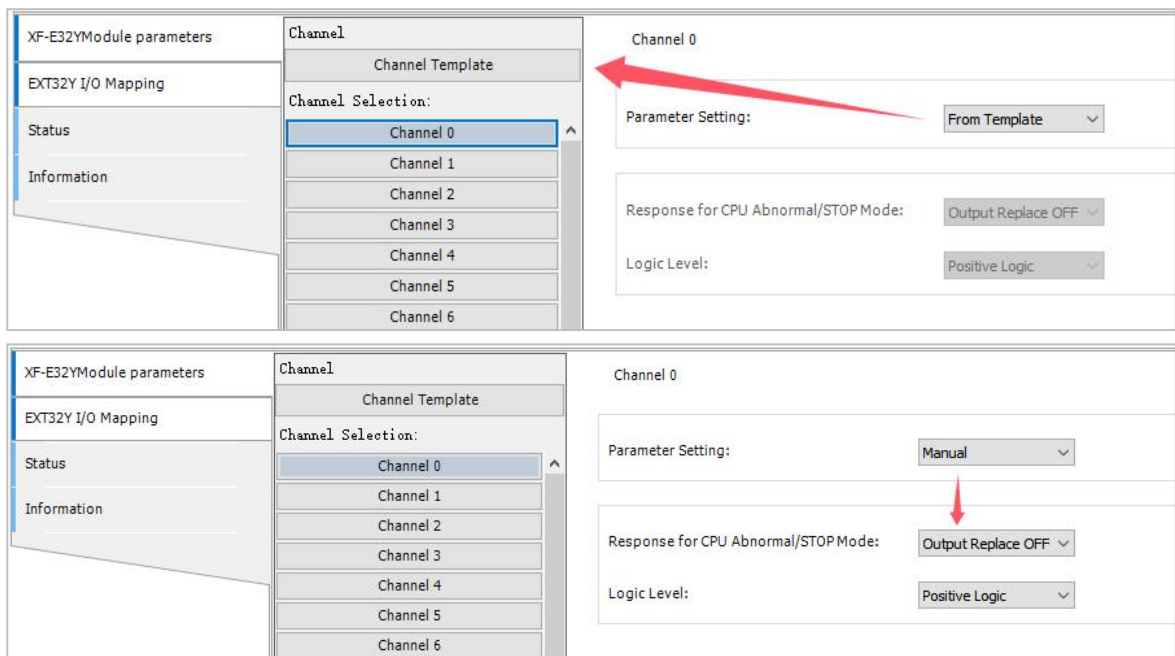

Each channel can be individually configured for CPU exception/STOP mode response and logic level.

Channel Settings	<p>From template: Use the configuration parameters in the "Channel Template" interface</p> <p>Manual: Use the configuration parameters at the bottom of this interface</p>
------------------	--

6.7 Digital Input/Output Unit XF-E16X16YT

6.7.1 Product Overview

The XF-E16X16YT series digital input expansion module features 16-channel digital inputs supporting NPN and PNP types, along with 16-channel digital outputs. It is compatible with XF/XSF series CPU units and XF series communication coupler units.

- 16-channel digital input;
- NPN and PNP bipolar inputs;
- 16-channel digital output;
- NPN output;
- 24mm width design;

■ Module Version

Hardware version	Firmware version	Function
H2.0	V2.0	The basic functions are now officially operational for the first time.

6.7.2 Module View

1) Explanation of each section

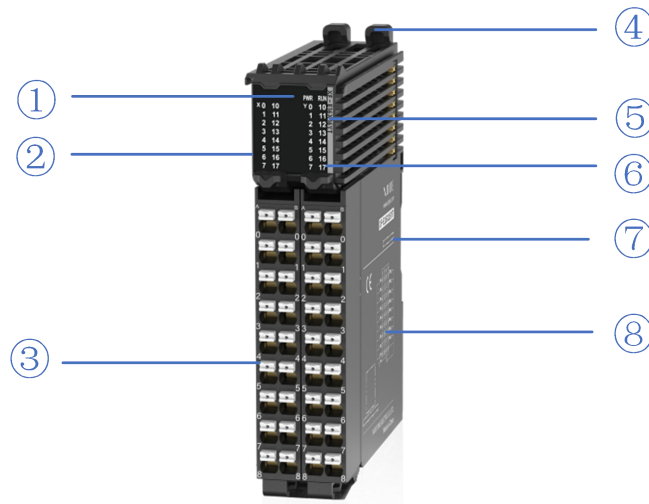

Number	Name	Number	Name
①	System LED indicator light	②	Channel LED indicator light
③	Disconnectable terminal block	④	Fastener
⑤	Model indication	⑥	Color code for indicator module type
⑦	Module hardware and Firmware version	⑧	Hookup

2) System Indicator Light

System Indicator Light	meaning	
PWR (green)	extinct	Module not powered (backplane bus)
	Always on	All power supplies for the module are functioning normally (backplane bus power and external 24V input).
	Flash 1Hz*1	Partial module power supply is abnormal and cannot operate normally (external)
RUN (green)	Always on	The module is running normally
	Flash 1Hz*1	The module encountered a general error in the log
	extinct	The module encountered a critical error in the log
	10Hz*2	Modeling communication
	Flash*3	Module heartbeat detection in progress
	Dual Flash*4	firmware update



- *1: The duty cycle is 50%, and the frequency is 1Hz, with a square wave.
- *2: The duty cycle is 50%, and the frequency is 10Hz, with a square wave.
- *3: Indicator light specification: ON:0.2s OFF:1.8s
- *4: The hazard lights are shown below:

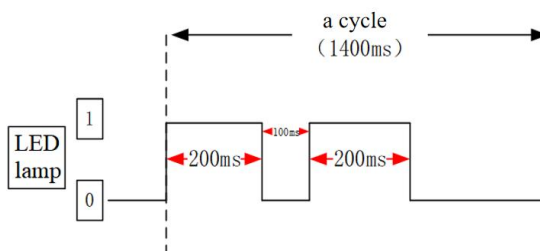

3) Channel indicator light light

model	Channel indicator light		
XF-E16X16YT	X0-X17	Always on (green)	The corresponding input channel has an ON signal.
		go out	The corresponding input channel has no ON signal
	Y0-Y17	Always on (green)	The corresponding output channel has an ON signal.
		go out	The corresponding output channel has no ON signal

4) Color labels

Number	Color	Module type
1	hoar	digital input
2	gray	digital output & digital mixing module
3	wathet	read analogue input

Number	Color	Module type
4	mazarine	analog output
5	green	232&485 serial communication
6	rose hermosa	Temperature signal input
7	white	high speed counting
8	purple	pulse output
9	red	repeater power supply

6.7.3 General Specifications

Project		Specifications
Operation temperature	Maximum temperature	55°C
	Minimum temperature	-20°C
Transportation/Storage Temperature	Maximum temperature	70°C
	Minimum temperature	-40°C
Environmental humidity (including operation/storage)	superior limit	95%
	lower limit	10%
Levels of protection		IP20
Anti-vibration		Complies with IEC61131-2 under intermittent vibration (frequency 5-9Hz, constant amplitude 3.5mm peak displacement) and (frequency 9-150Hz, constant acceleration 1.0g peak acceleration) The continuous shock vibration (5-9Hz, half amplitude 1.75mm displacement) and (9-150Hz, constant acceleration 0.5g, constant frame amplitude) Scan 10 times in X, Y, and Z directions
Shock resistance		Complies with IEC61131-2 standard Impact intensity of 15G (peak) was applied for 11ms on each of three mutually perpendicular axes, with 3 impacts per axis (total 18 impacts).
Operating environment		Non-corrosive gases
Operating altitude		0-2000 meters
Overvoltage class		II: Complies with IEC61131-2
Pollution level		2; Complies with IEC61131-2
Anti-interference EMC		Complies with IEC 61131-2 and IEC 61000-6-4 Type B
Relevant certifications		UL,CE

6.7.4 Technical Specifications

Project		Specifications
Import Specifications	Input channel	16
	Input type	NPN and PNP compatible
	Rated input voltage	DC24V
	Rated input current	4mA
	Input impedance	5.5KΩ
	On voltage	15V
	On Input current	2.5mA
	Enter the off voltage	5V
	Enter the off current	1mA
	Input derating	The system operates at 55°C with a 50% power reduction (when no more than 8 input points are ON simultaneously), or a 10°C reduction when all input points are ON.
	ON→OFF response time of input resistor (hardware)	0.1ms
Response time of input resistor from OFF to ON (hardware)	0.1ms	
Output Specifications	Outgoing channel	16
	Output type	Transistor(NPN)
	Rated load voltage	DC24V(DC21.6V~26.4V)
	Maximum load current	0.5A per point, 4A per module (maximum 2A for 4 points)
	Surge current protection	support
	Leakage current at off	below 0.1mA
	Output derating	The rated capacity is reduced by 50% when operating at 55°C (with the ON output current not exceeding 2A), or by 10°C when all output points are ON.
	Output ON→OFF response time (hardware)	0.1ms
	Output OFF→ON response time (hardware)	0.1ms
module specifications	Module dissipation	1W (internal backplane) + 2W (external input)
	Module weight	132g

6.7.5 Installation & Wiring

6.7.5.1 Appearance dimensions

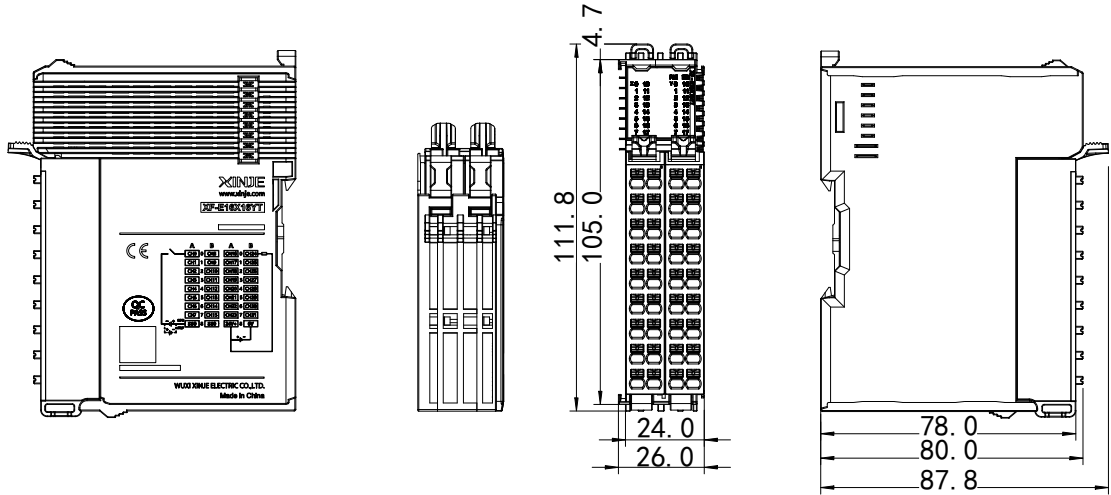

(unit: mm)

6.7.5.2 Terminal Definitions & Wiring

1) Terminal definition

XF-E16X16YT								
Meaning	A terminal (left)	Meaning	Column B terminal (left)	Terminal layout	Meaning	Column A terminal (right)	Meaning	Column B terminal (right)
CH0	0	CH8	0		CH16	0	CH24	0
CH1	1	CH9	1		CH17	1	CH25	1
CH2	2	CH10	2		CH18	2	CH26	2
CH3	3	CH11	3		CH19	3	CH27	3
CH4	4	CH12	4		CH20	4	CH28	4
CH5	5	CH13	5		CH21	5	CH29	5
CH6	6	CH14	6		CH22	6	CH30	6
CH7	7	CH15	7		CH23	7	CH31	7
SS0	8	SS0	8		24V+	8	0	8



Due to an internal short circuit in SS0, all input points of a single module must be configured as either NPN or PNP.

- NPN: The S/S terminal is 24V, while the X terminal is 0V.
- PNP: The S/S terminal is 0V, while the X terminal is 24V.

2) External wiring

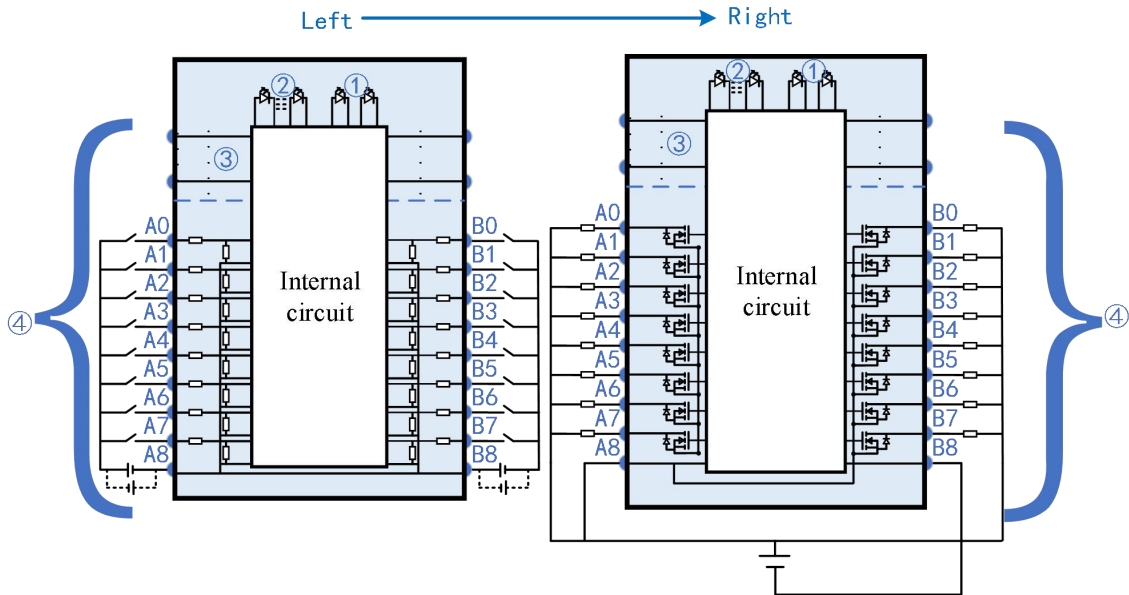

- ① System Indicator Light
- ② Channel indicator light
- ③ backplane bus light
- ④ Input and output channels & wiring

6.7.5.3 Installation Method

1) Installation requirements

The module is mounted using DIN rails that comply with IEC 60715 standards (35mm wide, 1mm thick). The dimensions are shown in the figure below, with measurements in millimeters.

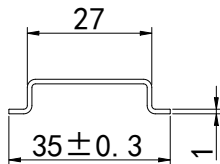

Attention

When the module is installed on a DIN rail not recommended above, the DIN rail latch may fail to lock properly.

2) Installation Steps

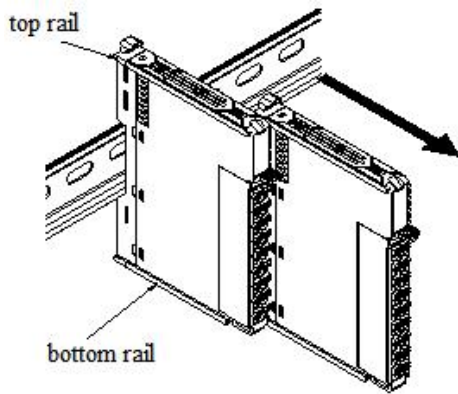

1. The IO modules are assembled by sliding along the top and bottom rails, as shown in the left figure.

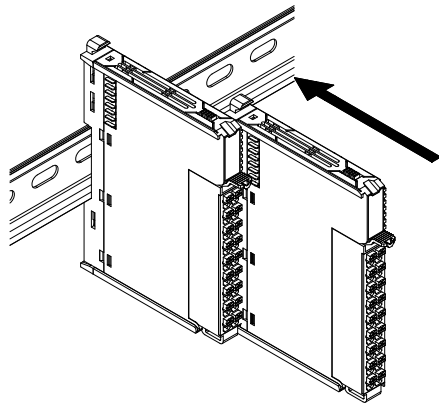

2. The module is mounted on the guide rail. During installation, align the module with the DIN guide rail and press it in the direction indicated by the arrow. A clear clicking sound will be heard when the module is properly secured, as shown in the left image.

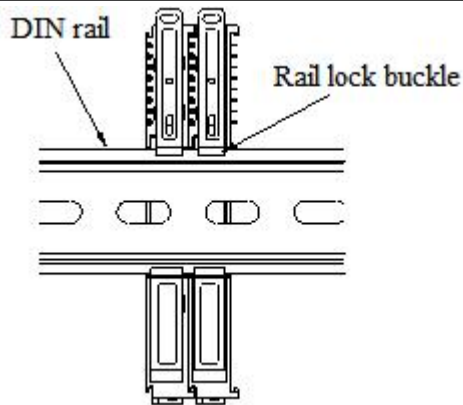

3. After module installation, the latch will automatically lower to lock. If it fails to move down, press the top of the latch downward to ensure proper installation.

3) Disassembly steps

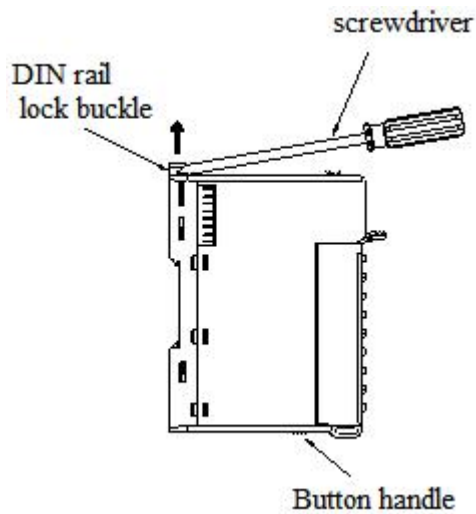

1. Use a screwdriver or similar tool to pry up the guide rail lock, as shown in the left image:

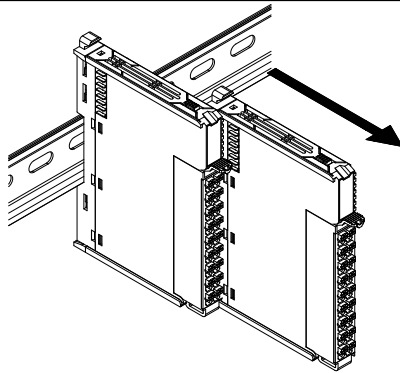

2. Pull the module straight forward from the buckle position (the raised part), then press down the top of the buckle as shown in the left image.

6.7.5.4 Installation Environment

This product supports four installation orientations: horizontal, vertical, top-mounted on electrical cabinets, and bottom-mounted. Horizontal installation is recommended. The cooling system utilizes natural convection. To ensure proper ventilation and heat dissipation while maintaining sufficient wiring clearance, a minimum clearance must be maintained around the product, as shown in the figure below.

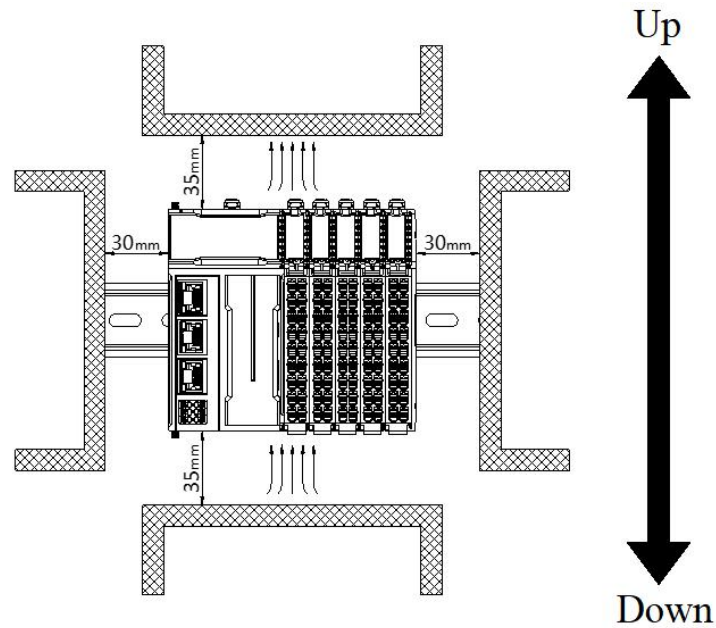

If the product is surrounded by high-temperature heat source equipment (heaters, transformers, high-resistance components, etc.), maintain a minimum clearance of 100mm between the product and such equipment.

6.7.5.5 Equipment Wiring

When wiring the module, its connectors must meet the following requirements:

Suitable wire gauge	
National standard/mm ²	American-Standard /AWG
0.3	22
0.5	20
0.75	18
1.0	18
1.5	16

If using other wire-type terminal lugs, press them onto the stranded wire as shown in the figure below for shape and size requirements.

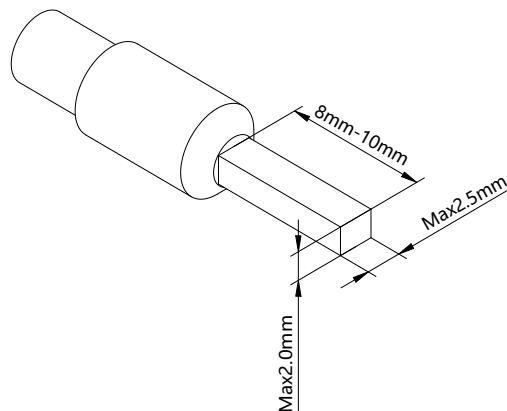

6.7.6 Parameters and Mapping Addresses

Name	Type	Explanation
XF_E16X16YT	Stuct	16-channel input and 16-channel output module
CH0	BOOL	Input value for channel 0
CH1	BOOL	Input value for channel 1
CH2	BOOL	Input value for channel 2
CH3	BOOL	Input value for channel 3
CH4	BOOL	Input value for channel 4
CH5	BOOL	Input value for channel 5
CH6	BOOL	Input value for channel 6
CH7	BOOL	Input value for channel 7
CH8	BOOL	Channel 8 input value
CH9	BOOL	Channel 9 input value
CH10	BOOL	Input value for channel 10
CH11	BOOL	Input value for channel 11
CH12	BOOL	Input value for channel 12
CH13	BOOL	Input value for channel 13
CH14	BOOL	Input value for channel 14
CH15	BOOL	Input value for channel 15
CH16	BOOL	Channel 16 output value
CH17	BOOL	Channel 17 output value
CH18	BOOL	Channel 18 output value
CH19	BOOL	Channel 19 output value
CH20	BOOL	Channel 20 output value
CH21	BOOL	Channel 21 output value
CH22	BOOL	Channel 22 output value
CH23	BOOL	Channel 23 output value
CH24	BOOL	Channel 24 output value

Name	Type	Explanation
XF_E16X16YT	Stuct	16-channel input and 16-channel output module
CH25	BOOL	Channel 25 output value
CH26	BOOL	Channel 26 output value
CH27	BOOL	Channel 27 output value
CH28	BOOL	Channel 28 output value
CH29	BOOL	Channel 29 output value
CH30	BOOL	Channel 30 output value
CH31	BOOL	Channel 31 output value
ErrCode_module	WORD	Module-level error code
ErrCode_CH	DWORD	Channel level error code

■ Error code parameter

Module-level error code (ErrCode_module)		
Bit	meaning	Error level
0	The 24V input power of the module is abnormal.	Medium
1	Incorrect module parameter assignment	Critical
2	An internal module error occurred and the user layer cannot fix it	Critical
3	Version mismatch	Critical



Channel level error code is reserved and not defined.

6.7.7 Functions and Settings

■ Channel Template

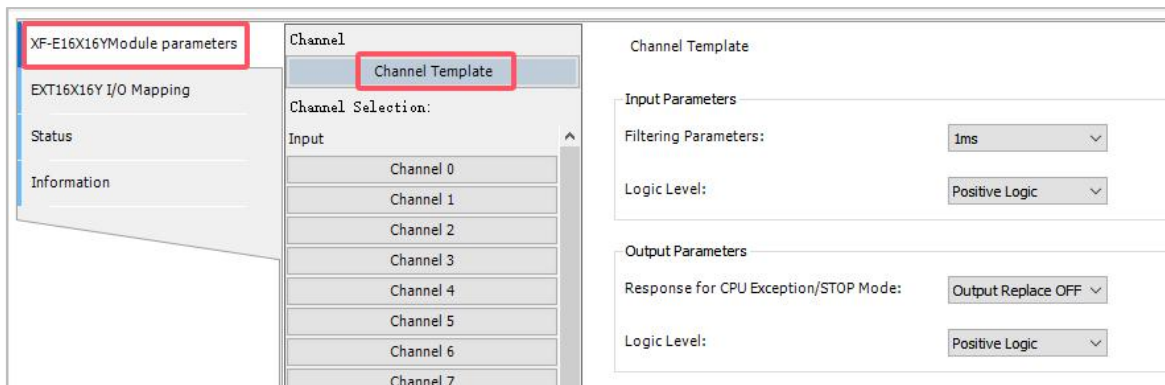

Input parameter	Initial value	Parameter declaration																	
Filter parameter	1ms	When the signal is present at the input terminal and the signal duration exceeds the filter time, it is regarded as a valid signal. Settable parameters: The following drop-down list shows the settable parameters: 0ms,0.25ms,0.5ms,1ms,2ms,3ms,4ms,5ms,6ms,7ms,8ms,9ms,10ms,11ms,12ms,13ms,14ms,15ms,20ms,30ms,64ms,128ms																	
logic level	positive logic	The logic of program execution after external signal input. <table border="1" style="margin-left: 20px;"> <thead> <tr> <th>External input Signal</th> <th>Logic level Configuration</th> <th>Program execution</th> <th>Result of Calculation</th> </tr> </thead> <tbody> <tr> <td>X0=1</td> <td>positive logic</td> <td rowspan="4" style="text-align: center;">LD X0; OUT Y0;</td> <td>Y0=1</td> </tr> <tr> <td>X0=1</td> <td>negative logic</td> <td>Y0=0</td> </tr> <tr> <td>X0=0</td> <td>positive logic</td> <td>Y0=0</td> </tr> <tr> <td>X0=0</td> <td>negative logic</td> <td>Y0=1</td> </tr> </tbody> </table>	External input Signal	Logic level Configuration	Program execution	Result of Calculation	X0=1	positive logic	LD X0; OUT Y0;	Y0=1	X0=1	negative logic	Y0=0	X0=0	positive logic	Y0=0	X0=0	negative logic	Y0=1
External input Signal	Logic level Configuration	Program execution	Result of Calculation																
X0=1	positive logic	LD X0; OUT Y0;	Y0=1																
X0=1	negative logic		Y0=0																
X0=0	positive logic		Y0=0																
X0=0	negative logic		Y0=1																

Out parameter	Initial value	Parameter declaration
Response to CPU/STOP mode	Replace OFF	"Output Replacement Value OFF" When the PLC is in STOP mode, the output terminals are reset (physical terminals, channel logic levels irrelevant) "Maintain previous value" When the PLC is in abnormal/STOP mode, the output terminal displays the final state from RUN to STOP (physical terminal, channel logic level irrelevant) "ON Output Replacement Value" When the PLC is in abnormal/STOP mode, the output terminals are set (physical terminals, channel logic levels irrelevant)

Out parameter	Initial value	Parameter declaration		
logic level	positive logic	Positive logic: When the program terminal is ON, the external terminal outputs		
		Negative logic: When the program terminal is set to OFF, the external terminal outputs		
		Logic Level Configuration	Running Program	Operation Result
		Positive Logic	SET Y0;	Y0 is set to ON
		Negative Logic	SET Y0;	Y0 is set to OFF
		Positive Logic	RST Y0;	Y0 is set to OFF
		Negative Logic	RST Y0;	Y0 is set to ON

■ Channel selection

● Import

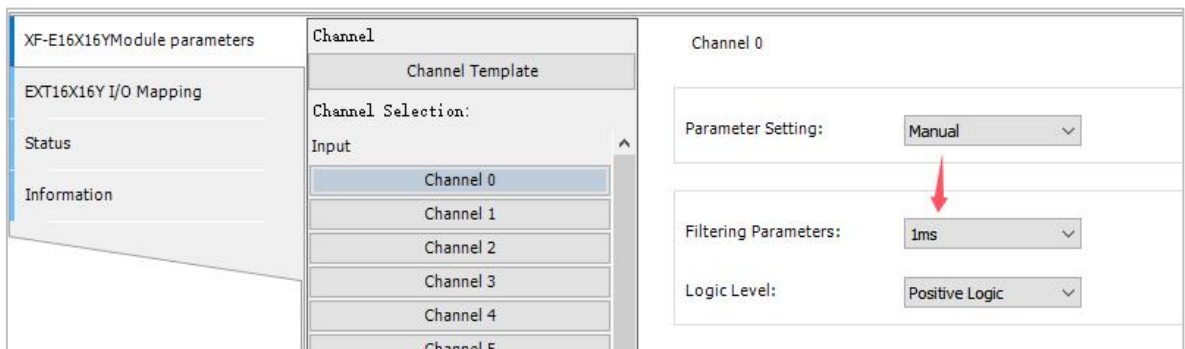
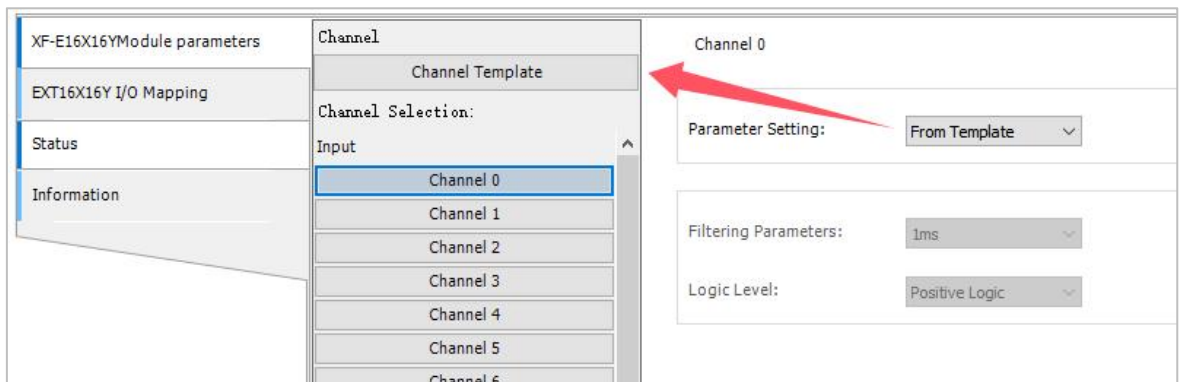

● Output

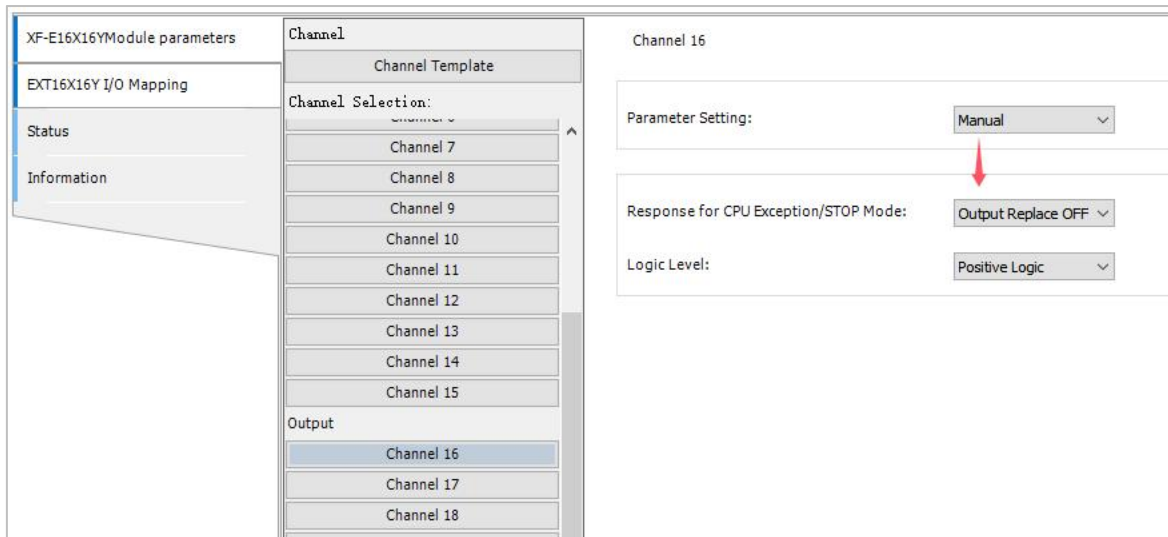
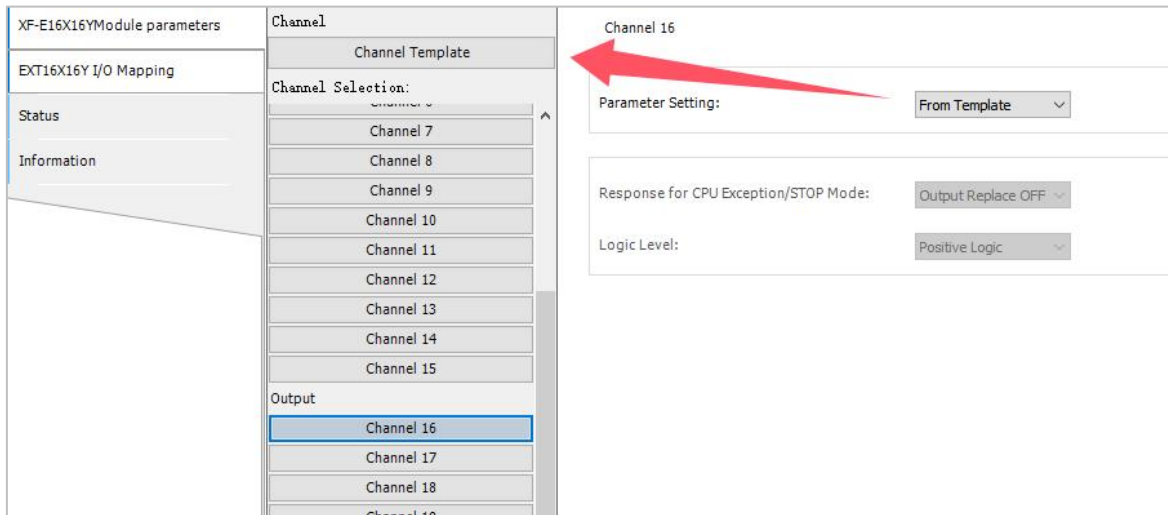

Filter parameters can be configured individually for each channel, including logic levels for CPU abnormal/STOP mode responses.

Channel Settings	<p>From template: Use the configuration parameters in the "Channel Template" interface.</p> <p>Manual: Use the configuration parameters at the bottom of this interface.</p>
------------------	--

6.8 Digital Output Unit XF-E8YR

6.8.1 Product Overview

The XF-E8YR is an output module of the XF series relay, powered by DC24V. The module provides 8 general-purpose digital output interfaces, driven by relays, and is compatible with XF and XSF series CPU units as well as XF series communication coupler units.

- 8-channel digital output;
- relay output;
- 24mm width design;

■ Module Version

Hardware version	Firmware version	function
H2.0	V2.0	The basic functions are now officially operational for the first time.

6.8.2 Module View

1) Explanation of each section

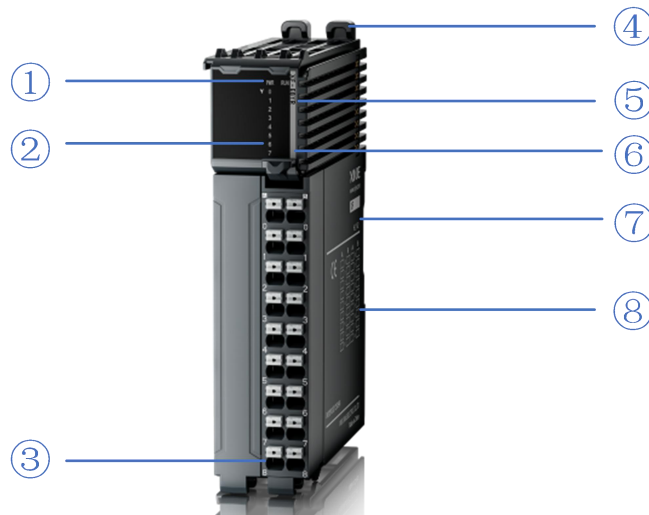

Number	Name	Number	Name
①	System LED indicator light	②	Channel LED indicator light
③	disconnectable terminal block	④	fastener
⑤	model indication	⑥	Color code for indicator module type
⑦	Module hardware and Firmware version	⑧	hookup

2) System Indicator Light

System indicator light	Meaning	
PWR (green)	extinct	Module not powered (backplane bus power)
	Always on	All external power supplies for the module are functioning normally (backplane bus power and external 24V input).
	Flash 1Hz* ¹	The module section is not functioning properly due to a power supply issue.
RUN (green)	Always on	The module is running normally
	Flash 1Hz* ¹	The module encountered a general error in the log
	extinct	The module encountered a critical error in the log
	10Hz* ²	Modeling communication
	Dual Flash* ³	firmware update



- *1: The duty cycle is 50%, and the frequency is 1Hz, with a square wave.
- *2: The duty cycle is 50%, and the frequency is a square wave of 10Hz.
- *3: The hazard lights are shown below:

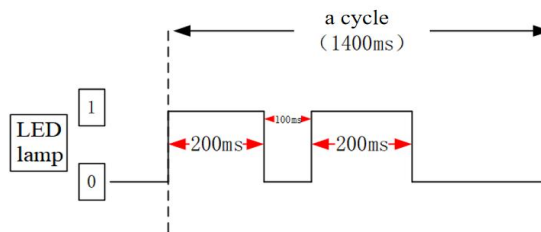

3) Channel indicator light light

Model	Channel indicator light		
XF-E8YR	Y0-Y7	Always on (green)	The corresponding output channel has an ON signal.
		go out	The corresponding output channel has no ON signal

4) Color labels

Number	Color		Module type
1		hoar	digital input
2		gray	digital output & digital mixing module
3		wathet	read analogue input
4		mazarine	analog output
5		green	232&485 serial communication
6		rose hermosa	Temperature signal input
7		white	high speed counting
8		purple	pulse output
9		red	repeater power supply

6.8.3 General Specifications

Project		Specifications
Operation temperature	Maximum temperature	55°C
	Minimum temperature	-20°C
Transportation/Storage Temperature	Maximum temperature	70°C
	Minimum temperature	-40°C
Environmental humidity (including operation/storage)	superior limit	95%
	lower limit	10%
Levels of protection		IP20
Anti-vibration		Complies with IEC61131-2 under intermittent vibration (frequency 5-9Hz, constant amplitude 3.5mm peak displacement) and (frequency 9-150Hz, constant acceleration 1.0g peak acceleration) The continuous shock vibration (5-9Hz, half amplitude 1.75mm displacement) and (9-150Hz, constant acceleration 0.5g, constant frame amplitude) Scan 10 times in X, Y, and Z directions
Shock resistance		Complies with IEC61131-2 standard Impact intensity of 15G (peak) was applied for 11ms on each of three mutually perpendicular axes, with 3 impacts per axis (total 18 impacts).
Operating environment		Non-corrosive gases
Operating altitude		0-2000 meters
Overvoltage class		II: Complies with IEC61131-2
Pollution level		2; Complies with IEC61131-2
Anti-interference EMC		Complies with IEC 61131-2 and IEC 61000-6-4 Type B
Relevant certifications		UL,CE

6.8.4 Technical Specifications

Project		Specifications
Output Specifications	Model	XF-E8YR
	Output points	8
	Output type	Dry contact type relay output
	The rated voltage of the power supply input to the terminal	DC24V±10%
	Output voltage level	AC 250V /DC 30V

Project		Specifications
	Output load (resistor load)	3A/1 point, 16A module
	Output load (inductive load)	1A/point, 4A/module
	Output load (light load)	30W per point, 120W per module
	Minimum dc load	DC 5V,2mA
	Minimum circulating load	AC 250V
	ON→OFF response time (hardware)	Under 15ms
	Output OFF→ON response time(hardware)	Under 15ms
	output decimation	The rated capacity is reduced by 50% when operating at 55°C (with the output current of ON not exceeding 8A), or by 10°C when all output points are ON.
	Public mode	1 port per device, with 8 ports in total (8-channel COM isolated)
	insulation method	relay isolation
	Module dissipation	0.6W (internal backplane) + 1.6W (external input)
	Module weight	120g

6.8.5 Installation & Wiring

6.8.5.1 Appearance dimensions

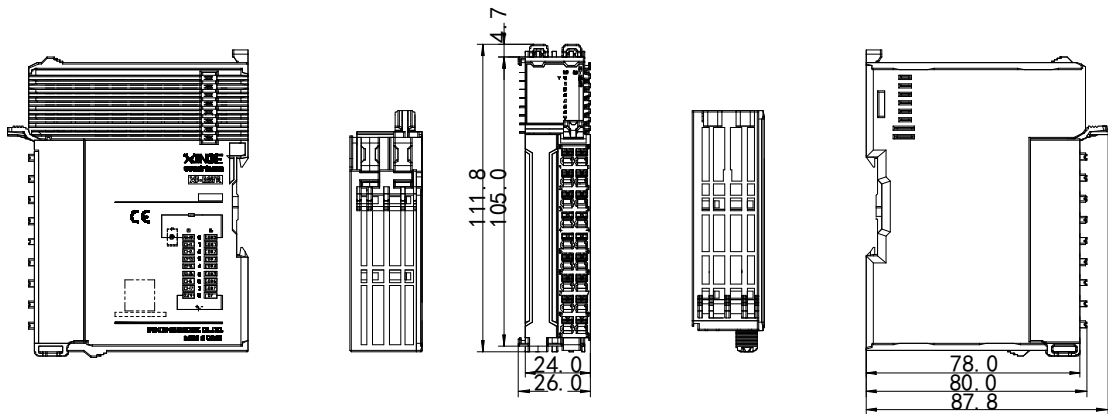

(unit :mm)

6.8.5.2 Terminal Definitions & Wiring

1) Terminal definition

Meaning	A column	Terminal arrangement	B column	Meaning
CH0	0		0	COM0

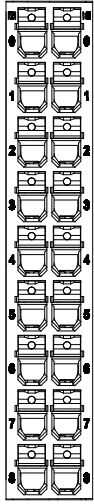
Meaning	A column	Terminal arrangement	B column	Meaning
CH1	1		1	COM1
CH2	2		2	COM2
CH3	3		3	COM3
CH4	4		4	COM4
CH5	5		5	COM5
CH6	6		6	COM6
CH7	7		7	COM7
24V+	8		8	0V



Internal power supply and external power supply are isolated.

2) External wiring

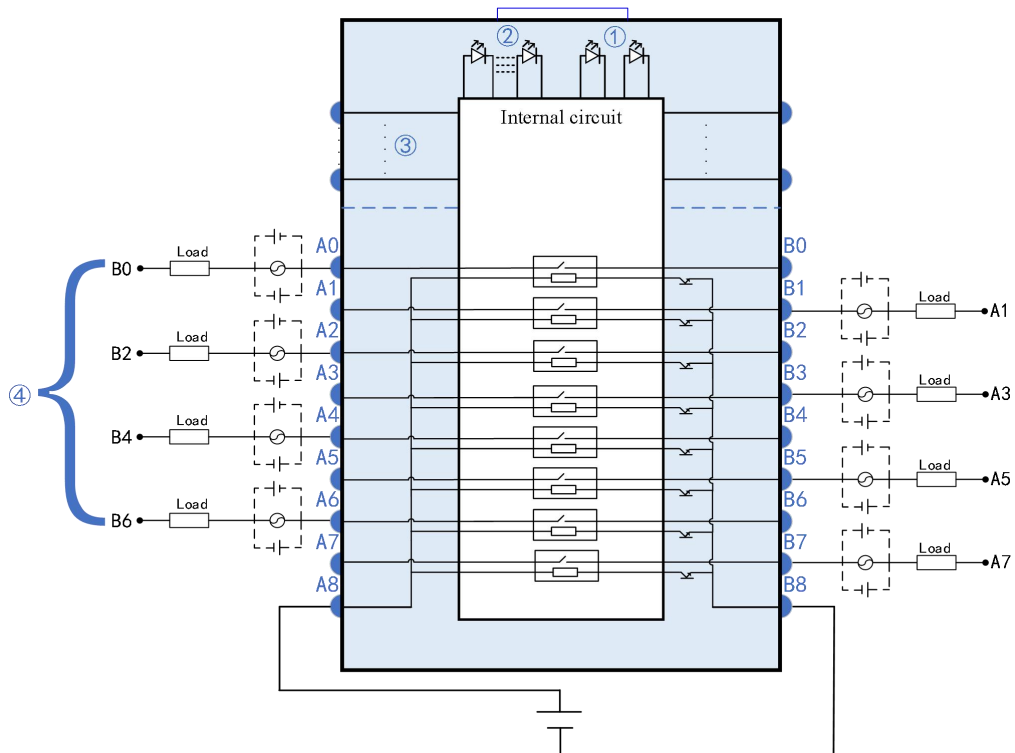

① System Indicator Light ② Channel indicator light backplane bus ④ Output channel & wiring

6.8.5.3 Installation Method

1) Installation requirements

The module is mounted using DIN rails that comply with IEC 60715 standards (35mm wide, 1mm thick). The dimensions are shown in the figure below, with measurements in millimeters.

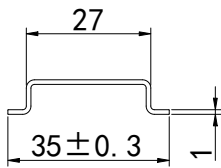

Attention

When the module is installed on a DIN rail not recommended above, the DIN rail latch may fail to lock properly.

2) Installation Steps

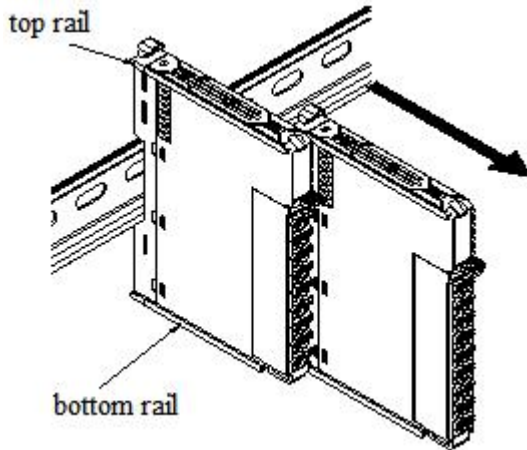

1. The IO modules are assembled by sliding along the top and bottom rails, as shown in the left figure.

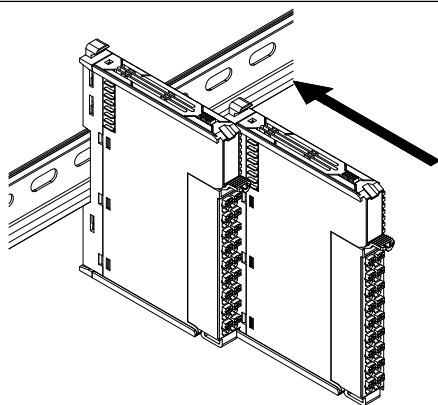

2. The module is mounted on the guide rail. During installation, align the module with the DIN guide rail and press it in the direction indicated by the arrow. A clear clicking sound will be heard when the module is properly secured, as shown in the left image.

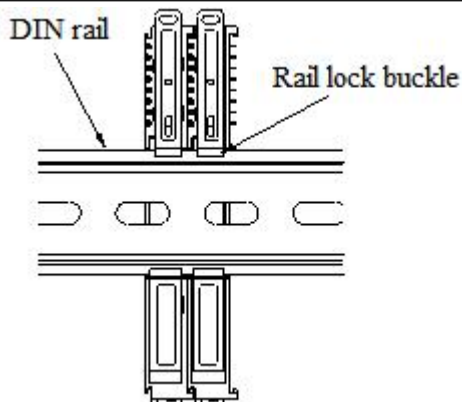

3. After module installation, the latch will automatically lower to lock. If it fails to move down, press the top of the latch downward to ensure proper installation.

3) Disassembly steps

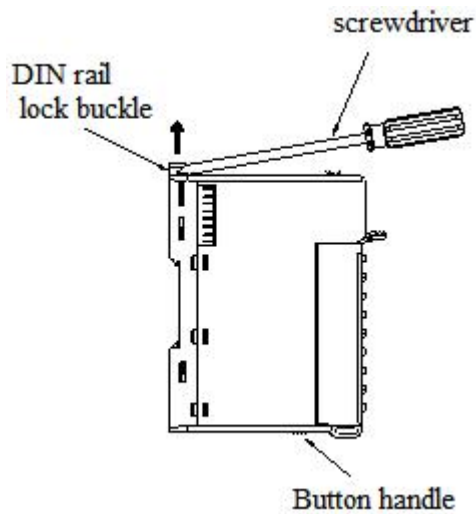

1. Use a screwdriver or similar tool to pry up the guide rail lock, as shown in the left image:

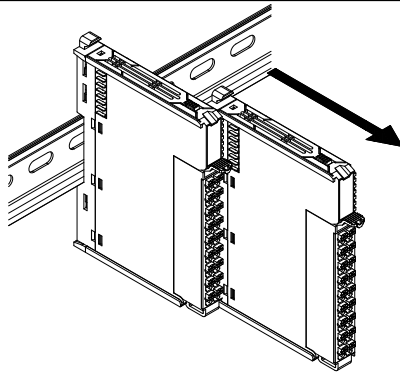

2. Pull the module straight forward from the buckle position (the raised part), then press down the top of the buckle as shown in the left image.

6.8.5.4 Installation Environment

This product supports four installation orientations: horizontal, vertical, top-mounted on electrical cabinets, and bottom-mounted. Horizontal installation is recommended. The cooling system utilizes natural convection. To ensure proper ventilation and heat dissipation while maintaining sufficient wiring clearance, a minimum clearance must be maintained around the product, as shown in the figure below.

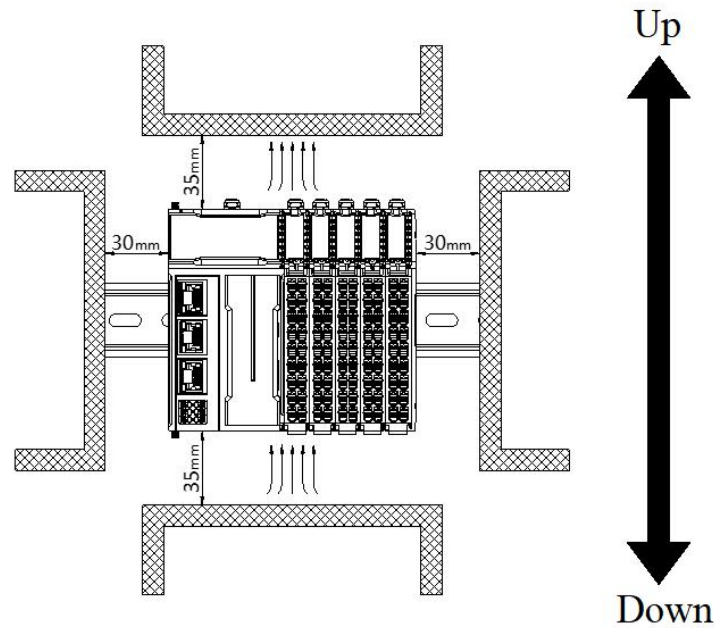

If the product is surrounded by high-temperature heat source equipment (heaters, transformers, high-resistance components, etc.), maintain a minimum clearance of 100mm between the product and such equipment.

6.8.5.5 Equipment Wiring

When wiring the module, its connectors must meet the following requirements:

Suitable wire gauge	
National standard/mm ²	American-Standard /AWG
0.3	22
0.5	20
0.75	18
1.0	18
1.5	16

If using other wire-type terminal lugs, press them onto the stranded wire as shown in the figure below for shape and size requirements.

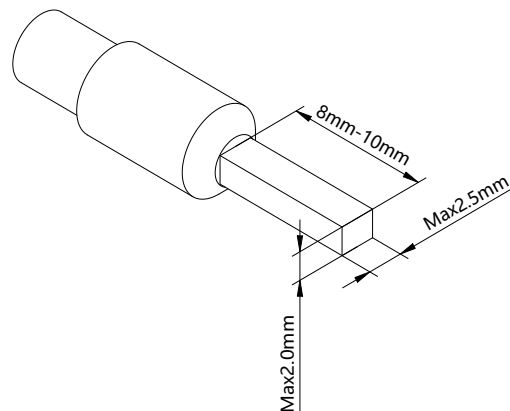

6.8.6 Parameters and Mapping Addresses

Name	Type	Explanation
XF_E8YR	Stuct	8-channel relay output module
ErrCode_module	WORD	Module-level error code
ErrCode_CH	DWORD	Channel level error code
CH0	BOOL	Channel 0 output value
CH1	BOOL	Channel 1 output value
CH2	BOOL	Channel 2 output value
CH3	BOOL	Channel 3 output value
CH4	BOOL	Channel 4 output value
CH5	BOOL	Channel 5 output value
CH6	BOOL	Channel 6 output value
CH7	BOOL	Channel 7 output value

■ Error code parameter

Module-level error code (ErrCode_module)		
Bit	meaning	Error level
0	The 24V input power of the module is abnormal.	Critical
2	An internal module error occurred and the user layer cannot fix it	Critical
3	Version mismatch	Critical



Channel level error code is reserved and not defined.

6.8.7 Functions and Settings

■ Channel Template

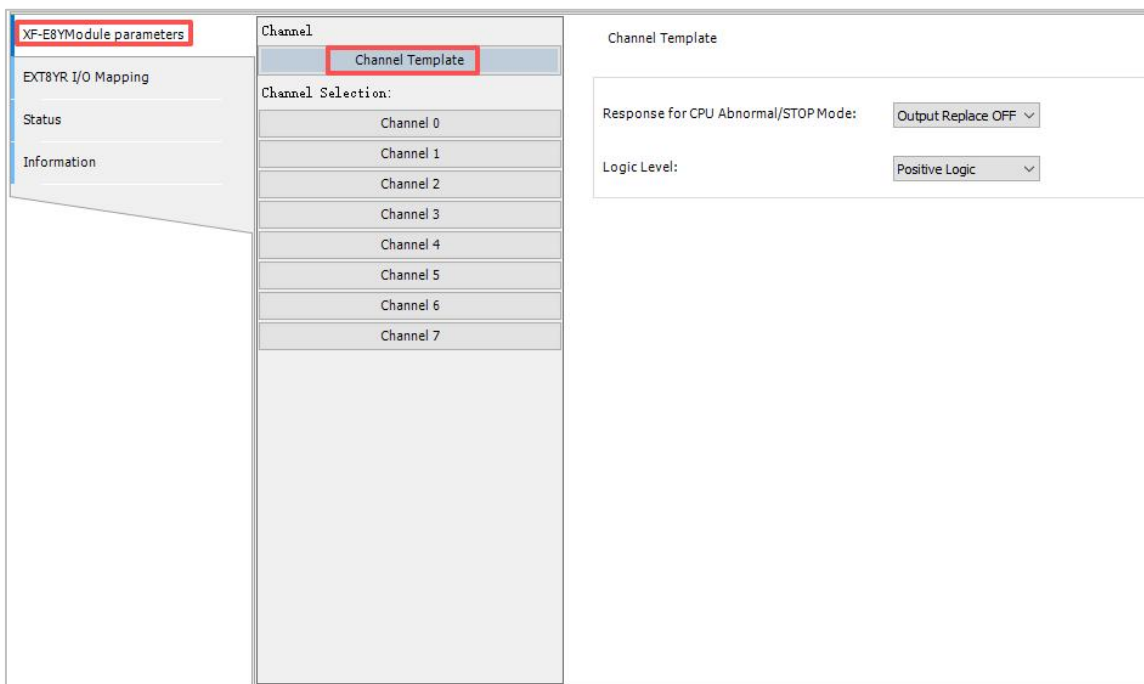

Out parameter	Initial value	Parameter declaration															
Response to CPU/STOP mode	Replace OFF	<p>"Output Replacement Value OFF" When the PLC is in STOP mode, the output terminals are reset (physical terminals, channel logic levels irrelevant)</p> <p>"Maintain previous value" When the PLC is in abnormal/STOP mode, the output terminal displays the final state from RUN to STOP (physical terminal, channel logic level irrelevant)</p> <p>"ON Output Replacement Value" When the PLC is in abnormal/STOP mode, the output terminals are set (physical terminals, channel logic levels irrelevant)</p>															
logic level	positive logic	<p>Positive logic: When the program terminal is ON, the external terminal outputs</p> <p>Negative logic: When the program terminal is set to OFF, the external terminal outputs</p> <table border="1"> <thead> <tr> <th>Logic Level Configuration</th> <th>Running Program</th> <th>Operation Result</th> </tr> </thead> <tbody> <tr> <td>Positive Logic</td> <td>SET Y0;</td> <td>Y0 is set to ON</td> </tr> <tr> <td>Negative Logic</td> <td>SET Y0;</td> <td>Y0 is set to OFF</td> </tr> <tr> <td>Positive Logic</td> <td>RST Y0;</td> <td>Y0 is set to OFF</td> </tr> <tr> <td>Negative Logic</td> <td>RST Y0;</td> <td>Y0 is set to ON</td> </tr> </tbody> </table>	Logic Level Configuration	Running Program	Operation Result	Positive Logic	SET Y0;	Y0 is set to ON	Negative Logic	SET Y0;	Y0 is set to OFF	Positive Logic	RST Y0;	Y0 is set to OFF	Negative Logic	RST Y0;	Y0 is set to ON
Logic Level Configuration	Running Program	Operation Result															
Positive Logic	SET Y0;	Y0 is set to ON															
Negative Logic	SET Y0;	Y0 is set to OFF															
Positive Logic	RST Y0;	Y0 is set to OFF															
Negative Logic	RST Y0;	Y0 is set to ON															

■ channel selection

- output

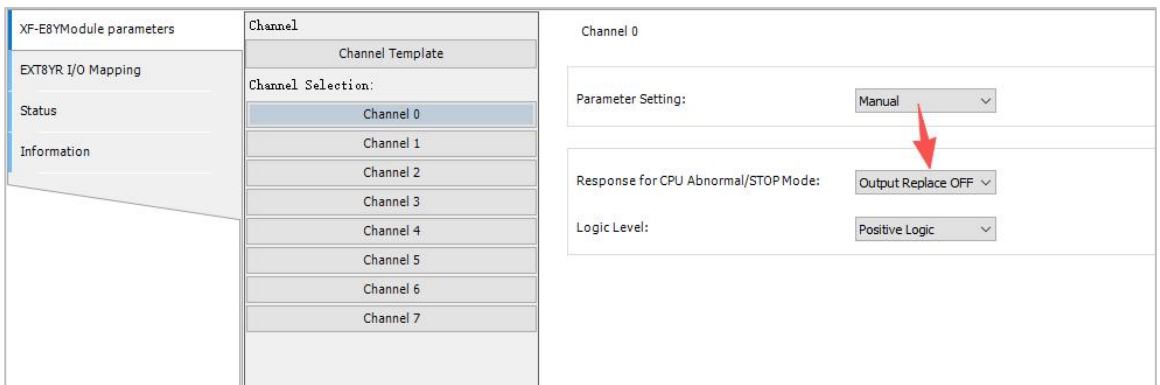
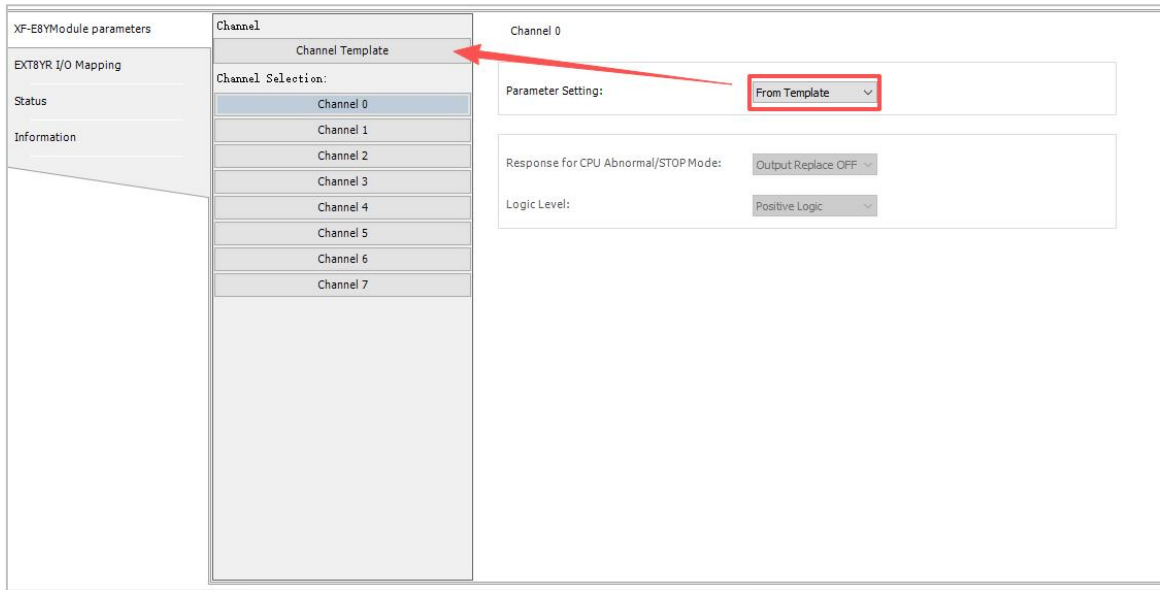

Filter parameters can be configured individually for each channel, including logic levels for CPU abnormal/STOP mode responses.

Channel Settings	<p>From template: Use the configuration parameters in the "Channel Template" interface.</p> <p>Manual: Use the configuration parameters at the bottom of this interface.</p>
------------------	--

7. Analog Module Unit

7.1 Naming Rules

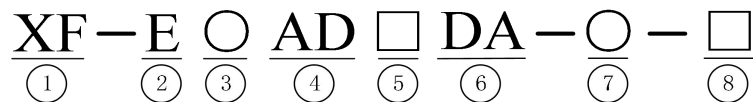

①	Series name	XF: XF series expansion module
②	Referential extension module	E: Right Extension Module
③	Input channel	1: 1 channel 2: 2 channel 4: 4 channel 6: 6 channel 8: 8 channel
④	Type	AD: Represents analog voltage and Input currents
⑤	Outgoing channel	1: 1 channel 2: 2 channel 4: 4 channel 6: 6 channel 8: 8 channel
⑥	Type	DA: Represents analog voltage and current outputs
⑦	Analog type	empty : Current & Voltage Type A: current type V: indicates voltage type
⑧	Module type	empty : conventional type H: channel isolation S: high-accuracy U: high speed

7.2 Analog Input Unit XF-E4AD

7.2.1 Product Overview

The XF-E4AD series analog input expansion module features 4-channel analog inputs supporting current and voltage measurements, compatible with XF/XSF series CPU units and XF series communication coupler units.

- 4-channel analog input;
- The channel switching speed is 60us per channel.
- Maximum error of 0.2%;
- bipolar input of voltage and current;
- 12mm width design.

■ Module Version

Hardware version	Firmware version	function
H2.0	V2.0	The basic functions are now officially operational for the first time.

7.2.2 Module View

1) Explanation of each section

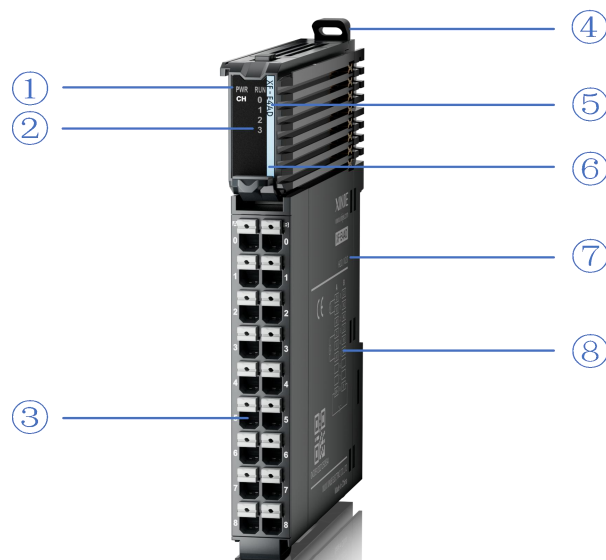

Number	Name	Number	Name
①	System LED indicator light	②	Channel LED indicator light
③	disconnectable terminal block	④	fastener
⑤	model indication	⑥	Color code for indicator module type
⑦	Module hardware and Firmware version	⑧	hookup

2) System Indicator Light

System indicator light	Meaning	
PWR (green)	extinct	The module is not powered on
	Always on	All external power supplies for the module are functioning normally (backplane bus power and external 24V input).
	Flash 1Hz* ¹	The module section is not functioning properly due to a power supply issue.
RUN (green)	Always on	The module is running normally
	Flash 1Hz* ¹	The module encountered a general error in the log
	extinct	The module encountered a critical error in the log
	10Hz* ²	Modeling communication
	Dual Flash* ³	firmware update



- *1: The duty cycle is 50%, and the frequency is 1Hz, with a square wave.
- *2: The duty cycle is 50%, and the frequency is 10Hz, with a square wave.
- *3: As shown below:

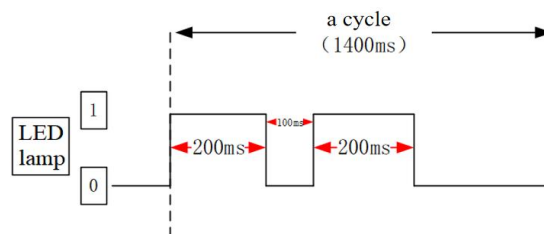

3) Channel indicator light light

Model	Channel indicator light		
XF-E4AD	CH0~CH3	Always on (green)	The channel is enabled and configured correctly
		10Hz Flash	The channel has an error message
		go out	forbidden channel

4) Color labels

Number	Color		Module type
1		hoar	digital input
2		gray	digital output & digital mixing module
3		wathet	read analogue input
4		mazarine	analog output
5		green	232&485 serial communication
6		rose hermosa	Temperature signal input
7		white	high speed counting
8		purple	pulse output
9		red	repeater power supply

7.2.3 General Specifications

Project		Specifications
Operation temperature	Maximum temperature	55°C
	Minimum temperature	-20°C
Transportation/Storage Temperature	Maximum temperature	70°C
	Minimum temperature	-40°C
Environmental humidity (including operation/storage)	superior limit	95%
	lower limit	10%
Levels of protection		IP20
Anti-vibration		Complies with IEC61131-2 under intermittent vibration (frequency 5-9Hz, constant amplitude 3.5mm peak displacement) and (frequency 9-150Hz, constant acceleration 1.0g peak acceleration) The continuous shock vibration (5-9Hz, half amplitude 1.75mm displacement) and (9-150Hz, constant acceleration 0.5g, constant frame amplitude) Scan 10 times in X, Y, and Z directions
Shock resistance		Complies with IEC61131-2 standard Impact intensity of 15G (peak) was applied for 11ms on each of three mutually perpendicular axes, with 3 impacts per axis (total 18 impacts).
Operating environment		Non-corrosive gases
Operating altitude		0-2000 meters
Overvoltage class		II: Complies with IEC61131-2
Pollution level		2; Complies with IEC61131-2
Anti-interference EMC		Complies with IEC 61131-2 and IEC 61000-6-4 Type B
Relevant certifications		CE

7.2.4 Technical Specifications

7.2.4.1 Module Performance

Project		Specifications
Input channel		4
Analog input range(rated)	Input voltage range	0V~5V(0~64000) 0V~10V(0~64000) -5V~5V(-32000~32000)

Project		Specifications
		-10V~10V(-32000~32000) 1v~5v(12800~64000) Impedance greater than 1M
	Input range	0mA~20mA(0~64000) 4mA~20mA(12800~64000) -20mA~20mA(-32000~32000) The impedance is approximately 120Ω.
Maximum output	Input voltage	DC±15V
Enter range	Input current	-40~40mA
Conversion rate		60us/CH
Response speed		60us
Resolution ratio		1/64000(16Bit)
Module power supply Source	Rated input	DC24V±10%, 150mA
	Protect	reverse protection
Error	Room temperature: 25°C ± 5°C	±0.1%(25±5 °C)
	Full temperature range: -20 to 55°C	±0.2%
Insulate		Channel is not isolated, power is isolated
Module dissipation		0.7W (internal backplane) + 0.5W (external input)
Module weight		80g

7.2.4.2 Module Conversion Diagram

1) Voltage

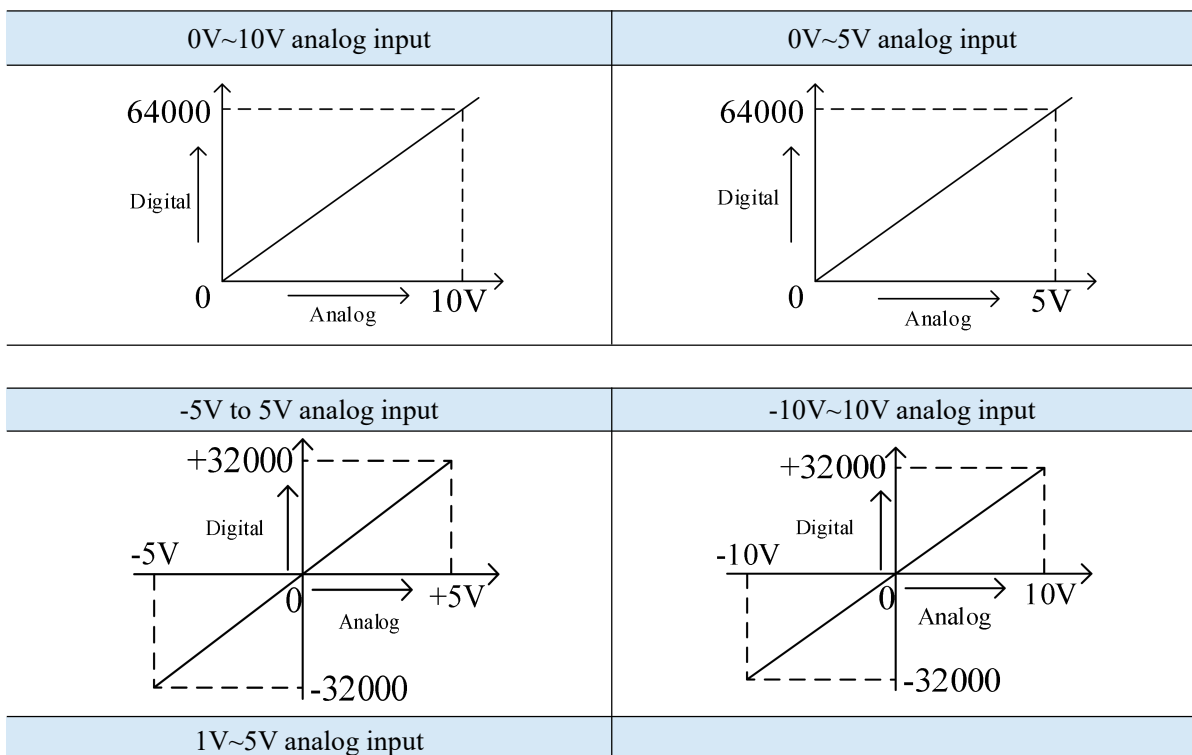

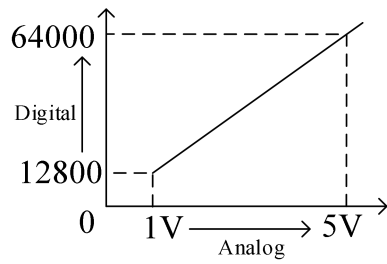

2) Current

0mA~20mA analog input	-20mA to 20mA analog input
<p>A line graph showing the relationship between Analog input (mA) and Digital output. The x-axis is labeled 'Analog' and has markers at 0 and 20mA. The y-axis is labeled 'Digital' and has markers at 0 and 64000. A solid line starts at (0, 0) and ends at (20mA, 64000). Dashed lines indicate the coordinates of the end point.</p>	<p>A line graph showing the relationship between Analog input (mA) and Digital output. The x-axis is labeled 'Analog' and has markers at -20mA, 0, and +20mA. The y-axis is labeled 'Digital' and has markers at -32000, 0, and +32000. A solid line passes through the origin (0, 0) and extends from (-20mA, -32000) to (+20mA, +32000). Dashed lines indicate the coordinates of the end points.</p>
4mA~20mA analog input	
<p>A line graph showing the relationship between Analog input (mA) and Digital output. The x-axis is labeled 'Analog' and has markers at 0, 4mA, and 20mA. The y-axis is labeled 'Digital' and has markers at 0, 12800, and 64000. A solid line starts at (4mA, 12800) and ends at (20mA, 64000). Dashed lines indicate the coordinates of these two points.</p>	

7.2.5 Installation & Wiring

7.2.5.1 Appearance dimensions

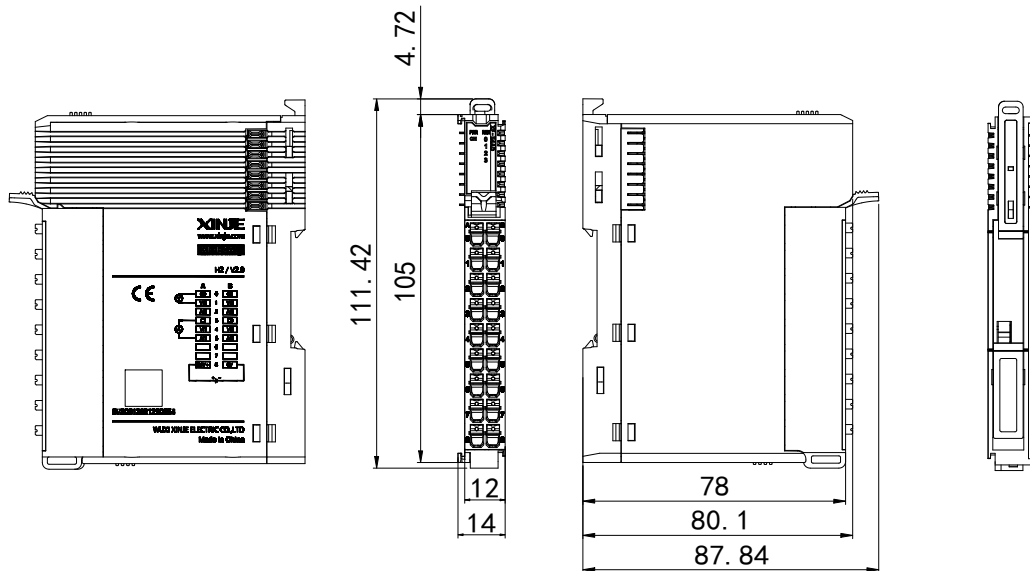

(unit: mm)

7.2.5.2 Terminal Definitions & Wiring

1) Terminal definition

XF-E4AD				
Meaning	A terminal	Terminal arrangement	B terminal	Meaning
CH0-Common input terminal	0		0	CH2-Input Common Terminal
CH0-AD analog voltage input terminal	1		1	CH2-AD analog voltage input terminal
CH0-AD analog Input current terminal	2		2	CH2-AD analog Input current terminal
CH1-Common input terminal	3		3	CH3-Input Common Terminal
CH1-AD Analog Voltage Input Terminal	4		4	CH3-AD Analog Voltage Input Terminal
CH1-AD Analog Input current Terminal	5		5	CH3-AD analog Input current terminal
empty	6		6	empty
empty	7		7	empty

XF-E4AD				
Meaning	A terminal	Terminal arrangement	B terminal	Meaning
The external module receives a 24V positive power supply.	8		8	The external module is powered by a 24V negative power supply.

2) External wiring

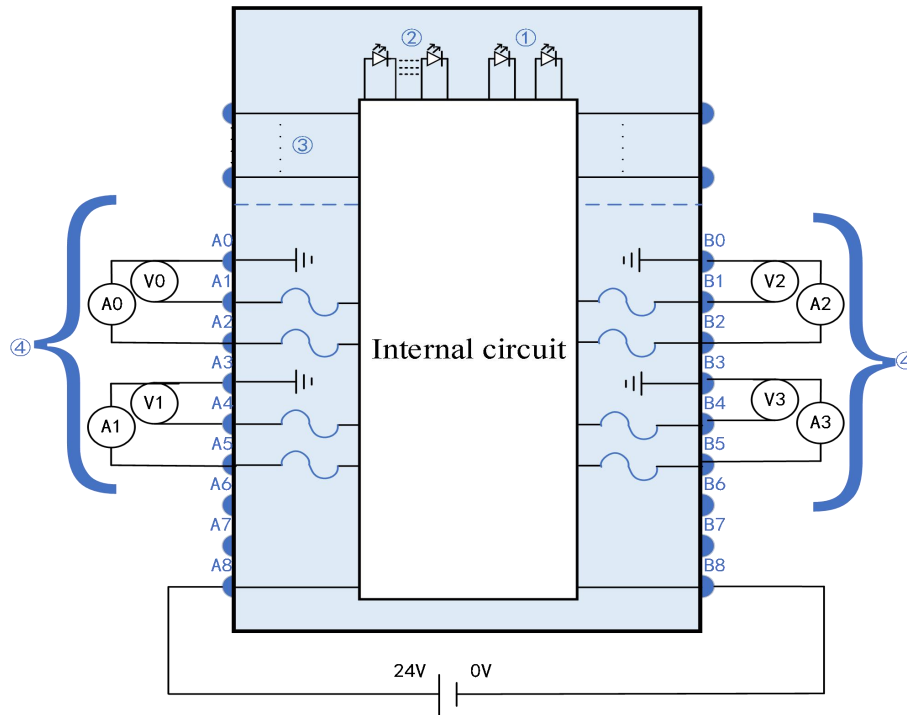

- ① System Indicator Light ② Channel indicator light ③ backplane bus ④ Input channel & wiring

7.2.5.3 Installation Method

1) Installation requirements

The module is mounted using DIN rails that comply with IEC 60715 standards (35mm wide, 1mm thick). The dimensions are shown in the figure below, with measurements in millimeters.

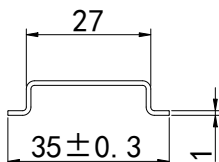

Attention

When the module is installed on a DIN rail not recommended above, the DIN rail latch may fail to lock properly.

2) Installation Steps

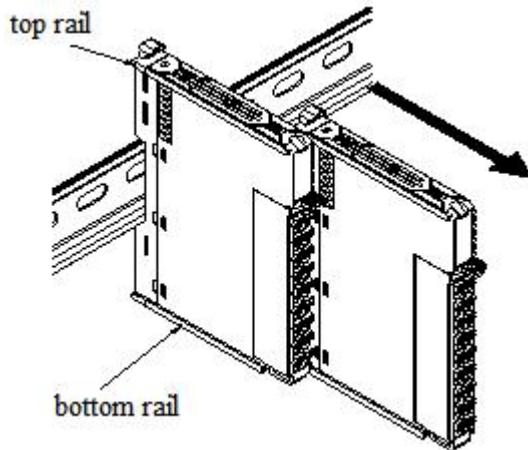

1. The IO modules are assembled by sliding along the top and bottom rails, as shown in the left figure.

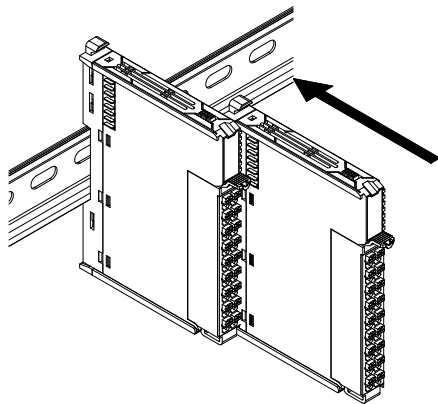

2. The module is mounted on the guide rail. During installation, align the module with the DIN guide rail and press it in the direction indicated by the arrow. A clear clicking sound will be heard when the module is properly secured, as shown in the left image.

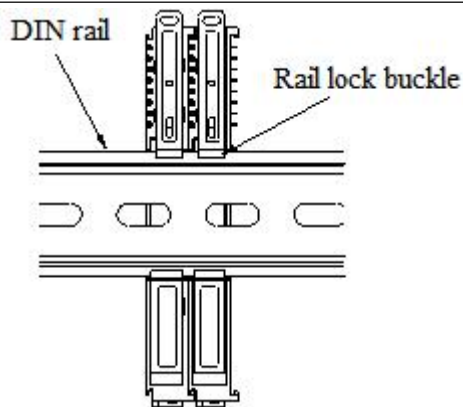

3. After module installation, the latch will automatically lower to lock. If it fails to move down, press the top of the latch downward to ensure proper installation.

3) Disassembly steps

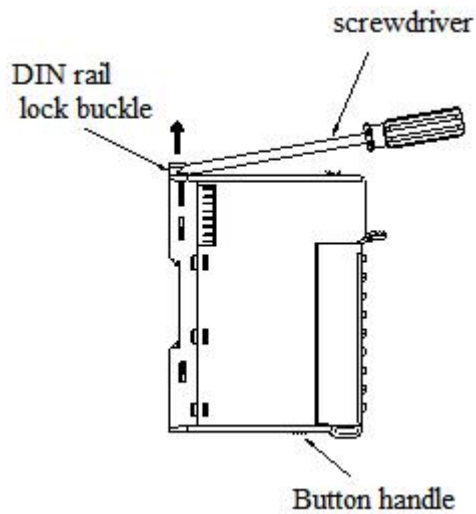

1. Use a screwdriver or similar tool to pry up the guide rail lock, as shown in the left image:

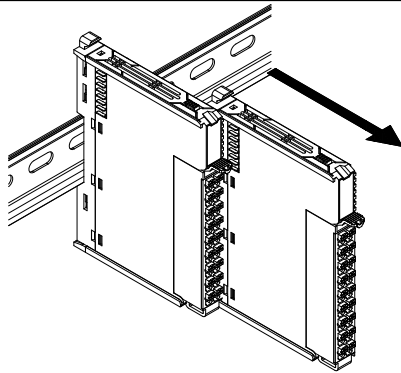

2. Pull the module straight forward from the buckle position (the raised part), then press down the top of the buckle as shown in the left image.

7.2.5.4 Installation Environment

This product supports four installation orientations: horizontal, vertical, top-mounted on electrical cabinets, and bottom-mounted. Horizontal installation is recommended. The cooling system utilizes natural convection. To ensure proper ventilation and heat dissipation while maintaining sufficient wiring clearance, a minimum clearance must be maintained around the product, as shown in the figure below.

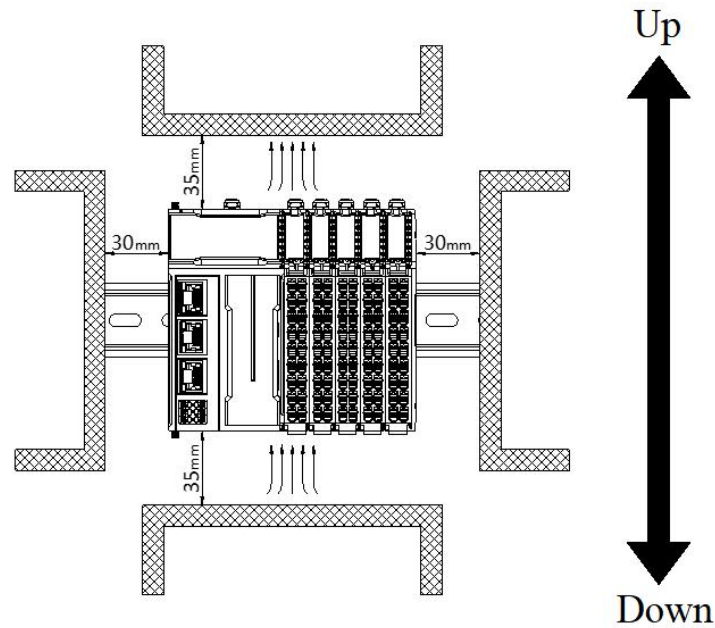

If the product is surrounded by high-temperature heat source equipment (heaters, transformers, high-resistance components, etc.), maintain a minimum clearance of 100mm between the product and such equipment.

7.2.5.5 Equipment Wiring

When wiring the module, its connectors must meet the following requirements:

Suitable wire gauge	
National standard/mm ²	American-Standard /AWG
0.3	22
0.5	20
0.75	18
1.0	18
1.5	16

If using other wire-type terminal lugs, press them onto the stranded wire as shown in the figure below for shape and size requirements.

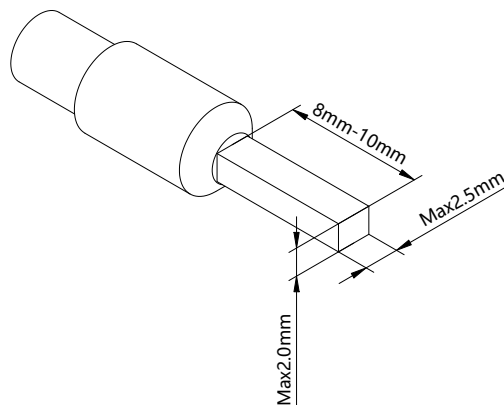

7.2.6 Parameters and Mapping Addresses

Name	Type	Explanation
XF_E4AD	Stuct	4-channel input module
CH0	DINT	Input value for channel 0
CH1	DINT	Input value for channel 1
CH2	DINT	Input value for channel 2
CH3	DINT	Input value for channel 3
ErrCode_module	WORD	Module-level error code
ErrCode_CH	DWORD	Channel level error code

■ Error code parameter

Module-level error code (ErrCode_module)		
Bit position	Meaning	Error level
0	The 24V input power of the module is abnormal.	Critical
2	An internal module error occurred and the user layer cannot fix it	Critical
3	Version mismatch	Critical
4	ADC/DAC read/write failure	Critical

Channel level error code (ErrCode_CH)		
Bit position	meaning	Error level
0	channel 0 overflow	Medium
1	channel 0 overflow	Medium
2	Channel 1 disconnected	Critical
3	obligate	-
4	channel 1 overflow	Medium
5	channel 1 lower limit overflow	Medium
6	Channel 1 disconnected	Critical
7	obligate	-
8	channel 2 overflow	Medium
9	channel 2 lower limit overflow	Medium
10	Channel 2 is disconnected	Critical
11	obligate	-
12	channel 3 overflow	Medium
13	channel 3 lower limit overflow	Medium
14	Channel 3 is disconnected	Critical

■ Configuration parameter

Parameter	Type	Channel	Meaning	Remarks
Power_Detection	Enumeration of BYTE	-	Power supply detection	0: Close 1: Open
CH0_enable_disable			Enable/Disable channel	0: Close 1: Open
CH0_broken_line_detecti on_enable_disable	Enumeration _of BYTE		Enable/Disable line break detection	0: Close 1: Open
CH0_range selection	BYTE		range selection	0: 0~10V 4: 1~5V 1: 0~5V 5: 0~20mA 2: -10~10V 6: 4~20mA 3: -5~5V 7: -20~20mA
CH0_filtering_mode			filtering mode	0: First-order filter 1: Time average 2: Average frequency 3: moving average
CH0_FilterPar	INT	channel 0	filter parameter	Time average (2-100ms) default value 2 Average count (4-500) Default value 4 Moving average (2-500) default value 2 The first-order delay filter (0-254) defaults to 0 (no filtering).
CH0_Calibrate_enable_di sable	Enumeration ofBYIE		Enable/Disable calibration	0: Close 1: Open
CH0_Calibration1_Analo g	INT		Calibrate 1 analog signal	Input voltage 0~10V:
CH0_Calibration1_Nume rical	DINT		Calibrate 1 digital quantity	Analog range: 0~10000mV Digital range: 0 to 64000
CH0_Calibration2_Analo g	INT		Calibrate the 2 analog signals.	0~5V: Analog range: 0~5000mV Digital range: 0 to 64000
CH0_Calibration2_Nume rical	DINT		Calibrate 2 digital quantities	-10~10V: Analog range: -10000 to 10000mV Digital range: -32000 to 32000
				-5~5V: Analog range: -5000 to 5000mV Digital range: -32000 to 32000
			1~5V: Analog range: 1000mV~5000mV Digital range: 12800 to 64000 Input current	

Parameter	Type	Channel	Meaning	Remarks
				0~20mA: Analog range: 0~20000μA Digital range: 0 to 64000 4~20mA: Analog range: 4000~20000uA Digital range: 12800 to 64000 -20~20mA: Analog range: -20000 to 20000μA Digital range: -32000 to 32000
CH0_unit_display_conversion_enabled_disable	Enumeration of BYTE		Enable/Disable unit display conversion	0: Close 1: Open
CH0_UpperLimit	DINT		Unit display conversion upper limit	Range: -100000000 to 100000000, and the converted unit must be greater than 0.
CH0_LowerLimit		Lower limit of unit conversion		
CH0_Upper_and_lower_limit_overflow_set_enabled_disable	Enumeration of BYTE		Enable/Disable upper/lower bound overflow	0: Close 1: Open
CH0_UpperAnalog	INT		overflow analog signal	Analog range: measured in mV or uA. For example: 0~10V
CH0_UpperNumerical	DINT		digital output of upper limit overflow	corresponds to 0~10000mV. Input voltage 0~10V:
CH0_LowerAnalog	INT		lower limit overflow analog quantity	Analog range: 0~10000mV Digital range: 0 to 64000 0~5V:
CH0_LowerNumerical	DINT		Lower limit overflow output digital quantity	Analog range: 0~5000mV Digital range: 0 to 64000 -10~10V: Analog range: -10000 to 10000 mV Digital range: -32000 to 32000 -5~5V: Analog range: -5000 to 5000mV Digital range: -32000 to 32000 1~5V: Analog range: 1000mV~5000mV Digital range: 12800 to 64000 Input current 0~20mA: Analog range: 0~20000μA Digital range: 0 to 64000 4~20mA: Analog range: 4000~20000uA

Parameter	Type	Channel	Meaning	Remarks
				Digital range: 12800 to 64000 -20~20mA: Analog range: -20000 to 20000μA Digital range: -32000 to 32000
CH1_enable_disable	Enumeration of BYTE	channel 1	Enable/Disable channel	0: Close 1: Open
CH1_broken_line_detection_enable_disable	Enumeration of BYTE		Enable/Disable line break detection	0: Close 1: Open
CH1_range selection	BYTE		range selection	0: 0~10V 4: 1~5V 1: 0~5V 5: 0~20mA 2: -10~10V 6: 4~20mA 3: -5~5V 7: -20~20mA
CH1_filtering_mode			filtering mode	0: First-order filter 1: Time average 2: Average frequency 3: moving average
CH1_FilterPar	INT		filter parameter	Time average (2-100ms) default value 2 Average count (4-500) Default value 4 Moving average (2-500) default value 2 The first-order delay filter (0-254) defaults to 0 (no filtering).
CH1_Calibrate_enable_disable	Enumeration of BYTE		Enable/Disable calibration	0: Close 1: Open
CH1_Calibration1_Analog	INT		Calibrate 1 analog signal	Input voltage 0~10V:
CH1_Calibration1_Numerical	DINT		Calibrate 1 digital quantity	Analog range: 0~10000mV Digital range: 0 to 64000
CH1_Calibration2_Analog	INT		Calibrate the 2 analog signals.	0~5V: Analog range: 0~5000mV
CH1_Calibration2_Numerical	DINT		Calibrate 2 digital quantities	Digital range: 0 to 64000 -10~10V: Analog range: -10000 to 10000 mV Digital range: -32000 to 32000 -5~5V: Analog range: -5000 to 5000 mV Digital range: -32000 to 32000 1~5V: Analog range: 1000mV~5000mV Digital range: 12800 to 64000 Input current 0~20mA: Analog range: 0~20000μA

Parameter	Type	Channel	Meaning	Remarks
				Digital range: 0 to 64000 4~20mA: Analog range: 4000~20000uA Digital range: 12800 to 64000 -20~20mA: Analog range: -20000 to 20000μA Digital range: -32000 to 32000
CH1_unit_display_conversion_enabled_disable	Enumeration of BYTE		Enable/Disable unit display conversion	0: Close 1: Open
CH1_UpperLimit	DINT		Unit display conversion upper limit	Range: -100000000 to 100000000, and the converted unit must be greater than 0.
CH1_LowerLimit		Lower limit of unit conversion		
CH1_Upper_and_lower_limit_overflow_set_enabled_disable	Enumeration of BYTE		Enable/Disable upper/lower bound overflow	0: Close 1: Open
CH1_UpperAnalog	INT		overflow analog signal	Analog range: measured in mV or uA. For example: 0~10V
CH1_UpperNumerical	DINT		digital output of upper limit overflow	corresponds to 0~10000mV. Input voltage 0~10V:
CH1_LowerAnalog	INT		lower limit overflow analog quantity	Analog range: 0~10000mV Digital range: 0 to 64000 0~5V:
CH1_LowerNumerical	DINT		Lower limit overflow output digital quantity	Analog range: 0~5000mV Digital range: 0 to 64000 -10~10V: Analog range: -10000 to 10000 mV Digital range: -32000 to 32000 -5~5V: Analog range: -5000 to 5000 mV Digital range: -32000 to 32000 1~5V: Analog range: 1000mV~5000mV Digital range: 12800 to 64000 Input current 0~20mA: Analog range: 0~20000μA Digital range: 0 to 64000 4~20mA: Analog range: 4000~20000uA Digital range: 12800 to 64000

Parameter	Type	Channel	Meaning	Remarks
				-20~20mA: Analog range: -20000 to 20000μA Digital range: -32000 to 32000
CH2_enable_disable	Enumeration of BYTE	channel 2	Enable/Disable channel	0: Close 1: Open
CH2_broken_line_detecti on_enable_disable	Enumeration of BYTE		Enable/Disable line break detection	0: Close 1: Open
CH2_range selection	BYTE		range selection	0: 0~10V 4: 1~5V 1: 0~5V 5: 0~20mA 2: -10~10V 6: 4~20mA 3: -5~5V 7: 20~20mA
CH2_filtering_mode				filtering mode
CH2_FilterPar	INT		filter parameter	Time average (2-100ms) default value 2 Average count (4-500) Default value 4 Moving average (2-500) default value 2 The first-order delay filter (0-254) defaults to 0 (no filtering).
CH2_Calibrate_enable_disable	Enumeration of BYIE		Enable/Disable calibration	0: Close 1: Open
CH2_Calibration1_Analog	INT		Calibrate 1 analog signal	Input voltage 0~10V:
CH2_Calibration1_Numerical	DINT		Calibrate 1 digital quantity	Analog range: 0~10000mV Digital range: 0 to 64000
CH2_Calibration2_Analog	INT		Calibrate the 2 analog signals.	0~5V: Analog range: 0~5000mV Digital range: 0 to 64000
CH2_Calibration2_Numerical	DINT		Calibrate 2 digital quantities	-10~10V: Analog range: -10000 to 10000 mV Digital range: -32000 to 32000 -5~5V: Analog range: -5000 to 5000 mV Digital range: -32000 to 32000 1~5V: Analog range: 1000mV~5000mV Digital range: 12800 to 64000 Input current 0~20mA:

Parameter	Type	Channel	Meaning	Remarks
				Analog range: 0~20000μA Digital range: 0 to 64000 4~20mA: Analog range: 4000~20000uA Digital range: 12800 to 64000 -20~20mA: Analog range: -20000 to 20000μA Digital range: -32000 to 32000
CH2_unit_display_conversion_enabled_disable	Enumeration of BYTE		Enable/Disable unit display conversion	0: Close 1: Open
CH2_UpperLimit	DINT		Unit display conversion upper limit	Range: -100000000 to 100000000, and the converted unit must be greater than 0.
CH2_LowerLimit		Lower limit of unit conversion		
CH2_Upper_and_lower_limit_overflow_set_enabled_disable	Enumeration of BYTE		Enable/Disable upper/lower bound overflow	0: Close 1: Open
CH2_UpperAnalog	INT		overflow analog signal	Analog range: measured in mV or uA. For example: 0~10V
CH2_UpperNumerical	DINT		digital output of upper limit overflow	corresponds to 0~10000mV. Input voltage 0~10V:
CH2_LowerAnalog	INT		lower limit overflow analog quantity	Analog range: 0~10000mV Digital range: 0 to 64000 0~5V:
CH2_LowerNumerical	DINT		Lower limit overflow output digital quantity	Analog range: 0~5000mV Digital range: 0 to 64000 -10~10V: Analog range: -10000 to 10000 mV Digital range: -32000 to 32000 -5~5V: Analog range: -5000 to 5000 mV Digital range: -32000 to 32000 1~5V: Analog range: 1000mV~5000mV Digital range: 12800 to 64000 Input current 0~20mA: Analog range: 0~20000μA Digital range: 0 to 64000 4~20mA: Analog range: 4000~20000uA

Parameter	Type	Channel	Meaning	Remarks
				Digital range: 12800 to 64000 -20~20mA: Analog range: -20000 to 20000μA Digital range: -32000 to 32000
CH3_enable_disable	Enumeration of BYTE	channel 3	Enable/Disable channel	0: Close 1: Open
CH3_broken_line_detection_enable_disable	Enumeration of BYTE		Enable/Disable line break detection	0: Close 1: Open
CH3_range selection	BYTE		range selection	0: 0~10V 4: 1~5V 1: 0~5V 5: 0~20mA 2: -10~10V 6: 4~20mA 3: -5~5V 7: -20~20mA
CH3_filtering_mode			filtering mode	0: First-order filter 1: Time average 2: Average frequency 3: moving average
CH3_FilterPar	INT		filter parameter	Time average (2-100ms) default value 2 Average count (4-500) Default value 4 Moving average (2-500) default value 2 The first-order delay filter (0-254) defaults to 0 (no filtering).
CH3_Calibrate_enable_disable	Enumeration of BYIE		Enable/Disable calibration	0: Close 1: Open
CH3_Calibration1_Analog	INT		Calibrate 1 analog signal	Input voltage 0~10V:
CH3_Calibration1_Numerical	DINT		Calibrate 1 digital quantity	Analog range: 0~10000mV Digital range: 0 to 64000
CH3_Calibration2_Analog	INT		Calibrate the 2 analog signals.	0~5V: Analog range: 0~5000mV
CH3_Calibration2_Numerical	DINT		Calibrate 2 digital quantities	Digital range: 0 to 64000 -10~10V: Analog range: -10000 to 10000 mV Digital range: -32000 to 32000 -5~5V: Analog range: -5000 to 5000 mV Digital range: -32000 to 32000 1~5V: Analog range: 1000mV~5000mV Digital range: 12800 to 64000 Input current

Parameter	Type	Channel	Meaning	Remarks
				0~20mA: Analog range: 0~20000μA Digital range: 0 to 64000 4~20mA: Analog range: 4000~20000uA Digital range: 12800 to 64000 -20~20mA: Analog range: -20000 to 20000μA Digital range: -32000 to 32000
CH3_unit_display_conversion_enabled_disable	Enumeration of BYTE		Enable/Disable unit display conversion	0: Close 1: Open
CH3_UpperLimit	DINT		Unit display conversion upper limit	Range: -100000000 to 100000000, and the converted unit must be greater than 0.
CH3_LowerLimit		Lower limit of unit conversion		
CH3_Upper_and_lower_limit_overflow_set_enabled_disable	Enumeration of BYTE		Enable/Disable upper/lower bound overflow	0: Close 1: Open
CH3_UpperAnalog	INT		overflow analog signal	Analog range: measured in mV or uA. For example: 0~10V
CH3_UpperNumerical	DINT		digital output of upper limit overflow	corresponds to 0~10000mV. Input voltage 0~10V:
CH3_LowerAnalog	INT		lower limit overflow analog quantity	Analog range: 0~10000mV Digital range: 0 to 64000 0~5V:
CH3_LowerNumerical	DINT		Lower limit overflow output digital quantity	Analog range: 0~5000mV Digital range: 0 to 64000 -10~10V: Analog range: -10000 to 10000 mV Digital range: -32000 to 32000 -5~5V: Analog range: -5000 to 5000 mV Digital range: -32000 to 32000 1~5V: Analog range: 1000mV~5000mV Digital range: 12800 to 64000 Input current 0~20mA: Analog range: 0~20000μA Digital range: 0 to 64000 4~20mA:

Parameter	Type	Channel	Meaning	Remarks
				Analog range: 4000~20000uA Digital range: 12800 to 64000 -20~20mA: Analog range: -20000 to 20000μA Digital range: -32000 to 32000

7.2.7 Functions and Settings

■ Enable/Disable channel

Enable or disable AD sampling channels to save module sampling time.

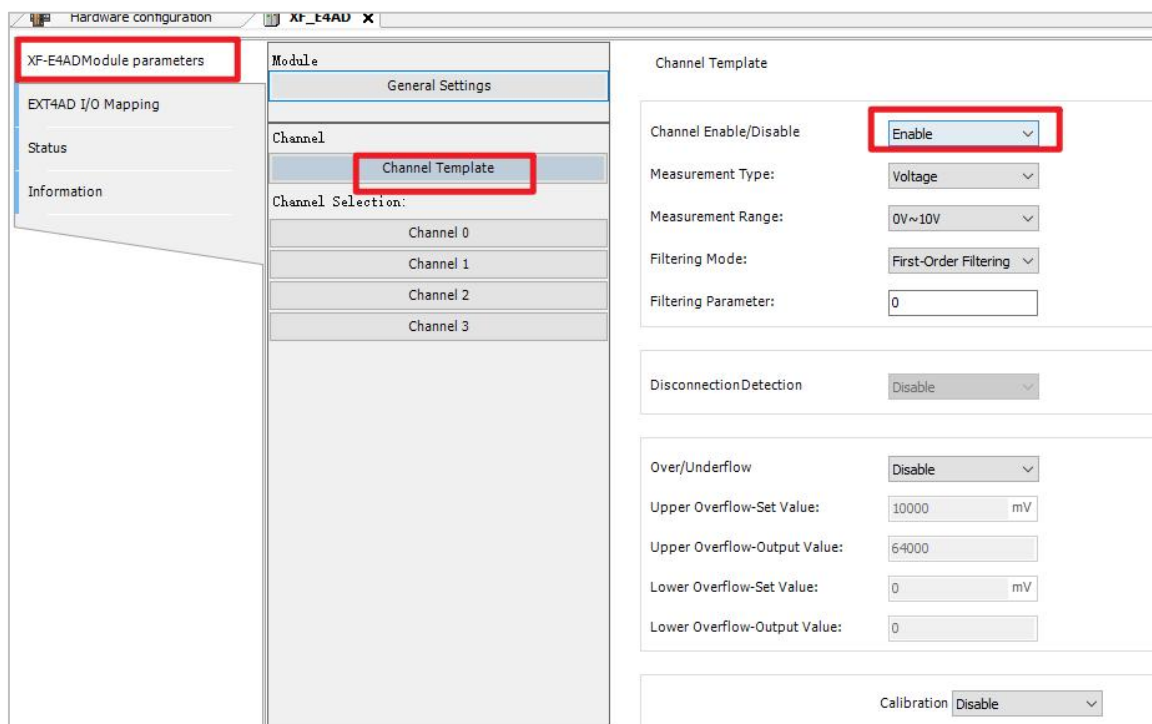

Parameters can be set	Enable or disable (After disabling, you cannot configure subsequent software functions for the corresponding channel)
Default parameters	start using
Matters need attention	Each channel has a conversion time of 60μs. The total time equals the switching speed multiplied by the number of active channels. To reduce the module's total conversion time, you can disable the channel if it is not in use.

■ channel selection

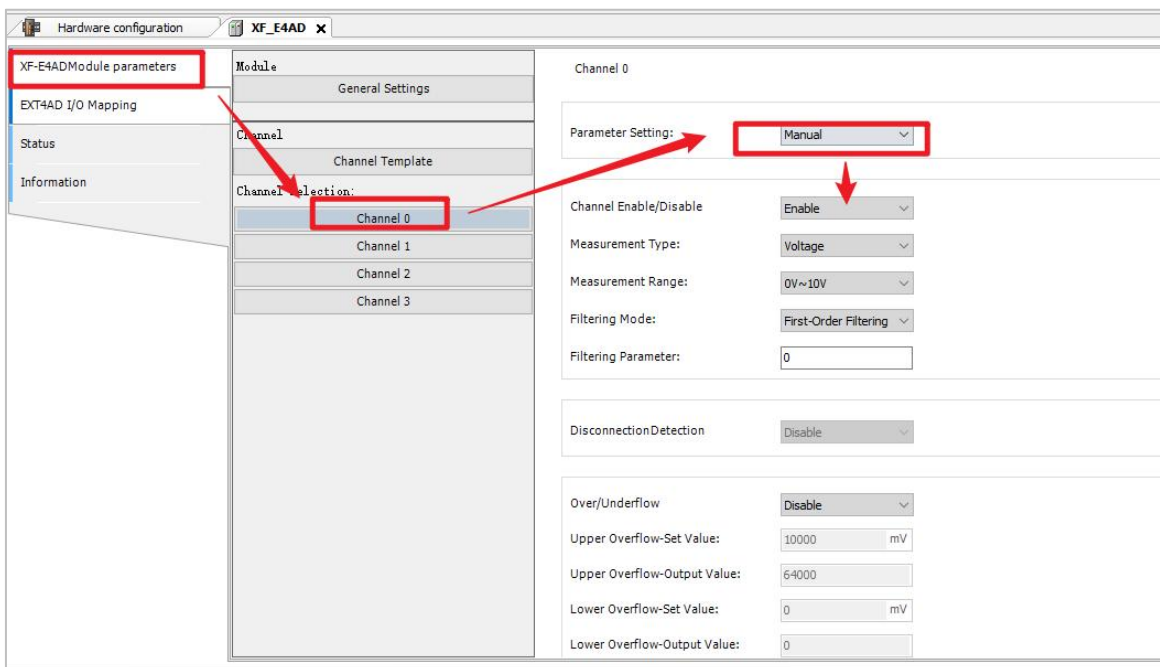
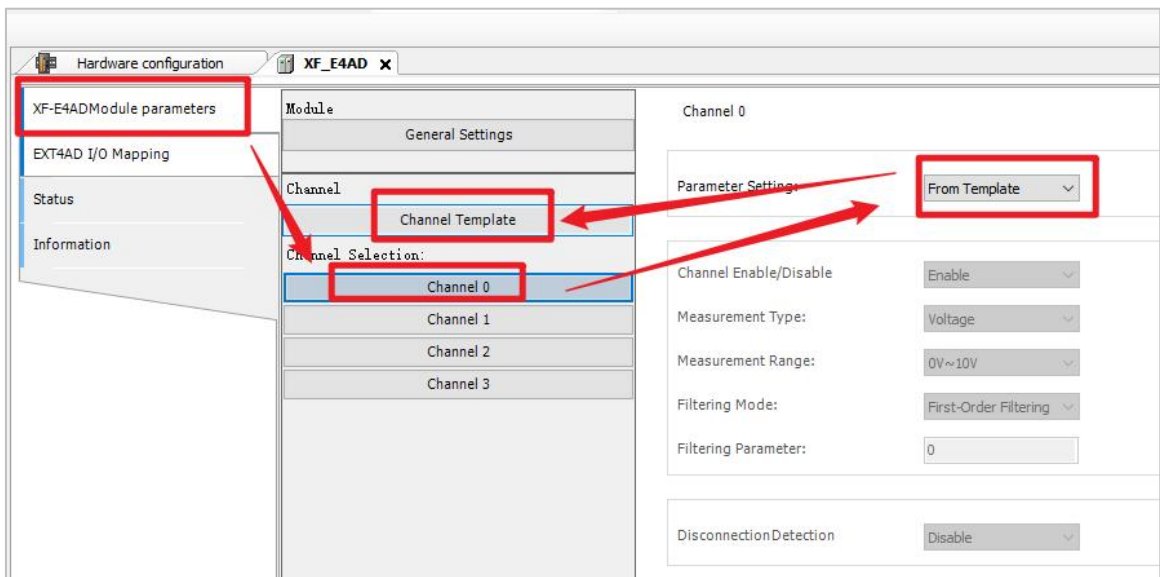

Channel Settings	<p>From Template: Use the configuration parameters from the "Channel Template" interface.</p> <p>Manual: Use the configuration parameters located below this interface.</p>
------------------	---

■ Sampling type/Range

You can choose different types and ranges of analog samples.

Parameter	Type	Value	Default Value	Unit	Description
Power_Detection	Enumeration of BYTE	OFF	OFF		Power supply detection
CH0_enable_disable	Enumeration of BYTE	ON	ON		channel 0 enable disable
CH0_broken_line_detection_enable_disable	Enumeration of BYTE	OFF	OFF		channel 0 broken line detection enable disable , bit3=0 filtering mode
CH0_range_selection	BYTE	0	0		channel 0 range select
CH0_filtering_mode	BYTE	0	0		channel 0 filtering mode
CH0_FilterPar	INT	0	0		channel 0 filter parameter
CH0_Calibrate_enable_disable	Enumeration of BYTE	OFF	OFF		channel 0 calibrate enable disable
CH0_Calibration1_Analog	INT	0	0		channel 0 Calibration1 analog quantity
CH0_Calibration1_Numerical	DINT	0	0		channel 0 Calibration1 numerical quantity
CH0_Calibration2_Analog	INT	10000	10000		channel 0 Calibration2 analog quantity
CH0_Calibration2_Numerical	DINT	64000	64000		channel 0 Calibration2 numerical quantity
CH0_unit_display_conversion_enabled_disable	Enumeration of BYTE	OFF	OFF		channel 0 unit display conversion enabled disable
CH0_UpperLimit	DINT	32000	32000		channel 0 unit displays the upper conversion limit
CH0_LowerLimit	DINT	0	0		channel 0 unit displays the lower conversion limit
CH0_Upper_and_lower_limit_overflow_set_enabled_disable	Enumeration of BYTE	OFF	OFF		channel 0 Upper and lower limit overflow set enabled disable
CH0_UpperAnalog	INT	10000	10000		channel 0 upper overflow analog
CH0_UpperNumerical	DINT	64000	64000		channel 0 upper limit overflows the number of output digits
CH0_LowerAnalog	INT	0	0		channel 0 lower overflow analog
CH0_LowerNumerical	DINT	0	0		channel 0 lower limit overflows the number of output digits
CH1_enable_disable	Enumeration of BYTE	ON	ON		channel 1 enable disable
CH1_broken_line_detection_enable_disable	Enumeration of BYTE	OFF	OFF		channel 1 broken line detection enable disable , bit3=0 filtering mode
CH1_range_selection	BYTE	0	0		channel 1 range select
CH1_filtering_mode	BYTE	0	0		channel 1 filtering mode
CH1_FilterPar	INT	0	0		channel 1 filter parameter
CH1_Calibrate_enable_disable	Enumeration of BYTE	OFF	OFF		channel 1 calibrate enable disable
CH1_Calibration1_Analog	INT	0	0		channel 1 Calibration1 analog quantity

Parameters can be set	The table below shows configurable parameters: voltage and current
Default parameters	voltage
Voltage measurement range	0V~5V,0V~10V,-5V~5V,-10V~10V,1V~5V Default: 0V~10V
current measurement range	0mA~20 mA, 4mA~20mA, -20mA~20mA

■ Module Power Detection

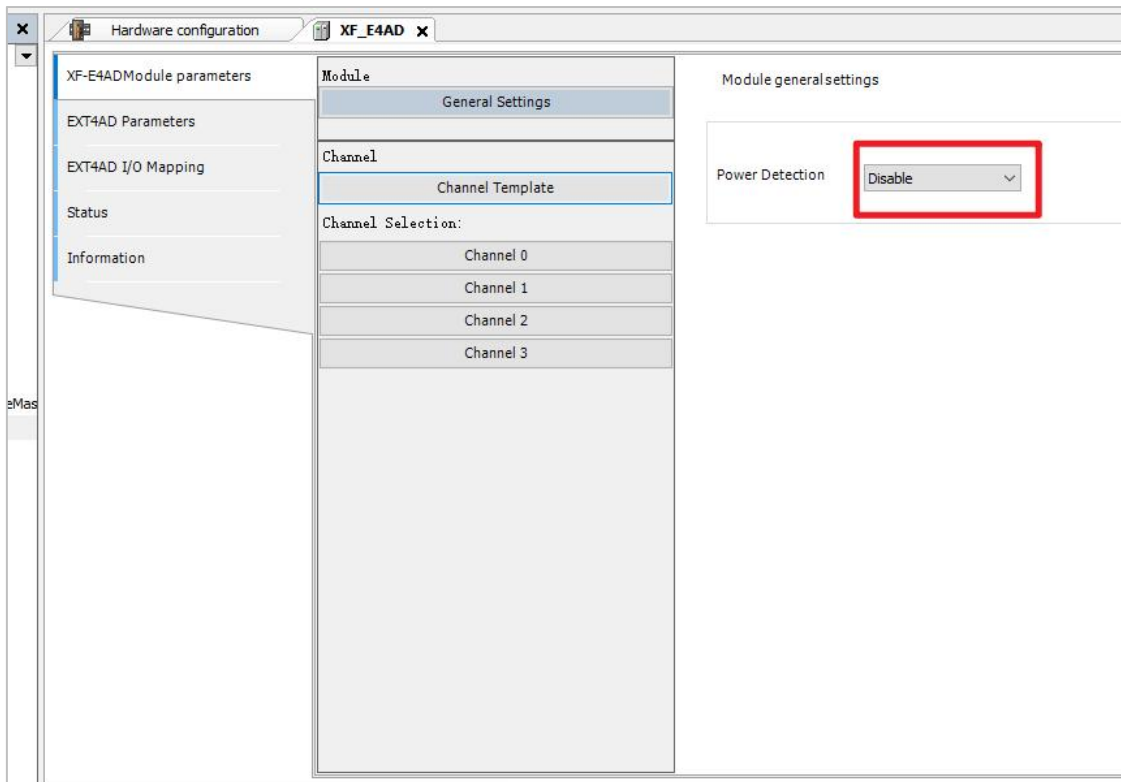

■ Wire break detection

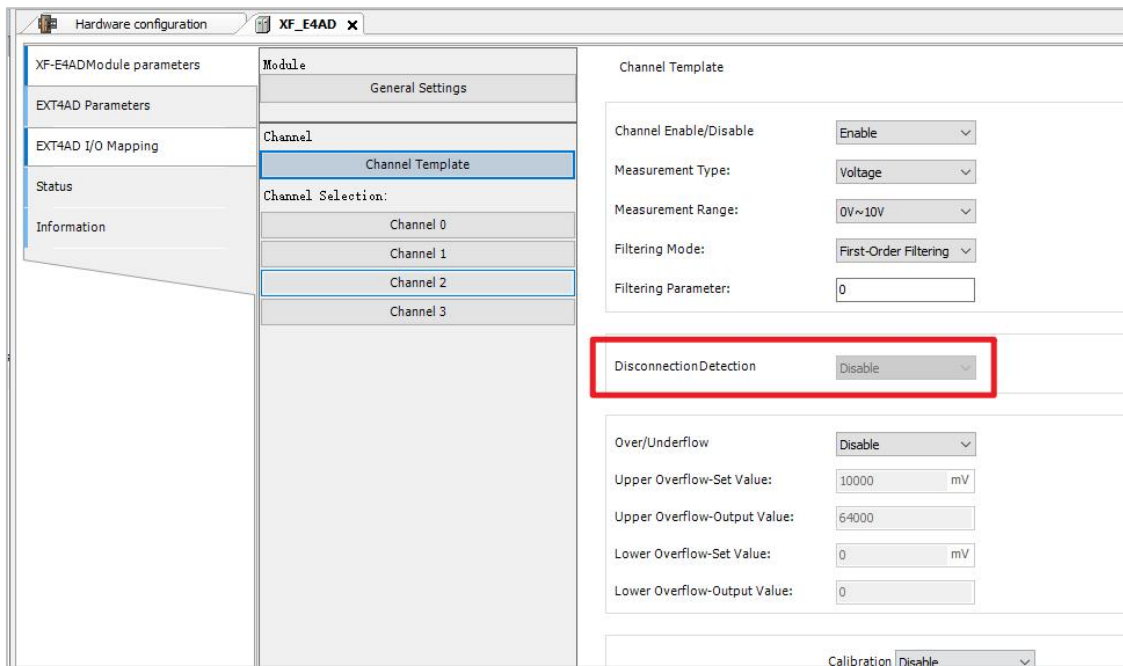

Check whether the 24V external power supply of the detection module is normal:

- Normal: The module operates properly.
- Abnormal: The module channels are unavailable, but configuration, parameter setting and scanning can still be performed normally.

Configurable parameter: Enable/Disable (Disable by default).

Detect the abnormal disconnection of the AD input channel and configure the alarm log accordingly. If no current flows through the module or the current is too low (measurement range: 4–20 mA or 1–5 V), the corresponding alarm log will be triggered, and both open-circuit detection and underflow can be activated simultaneously.

Configurable parameter: Enable/Disable (Disable by default).



Only the "Measurement Range" set to "4mA ~ 20mA" and "1V ~ 5V" supports this function.

■ Channel filter parameter

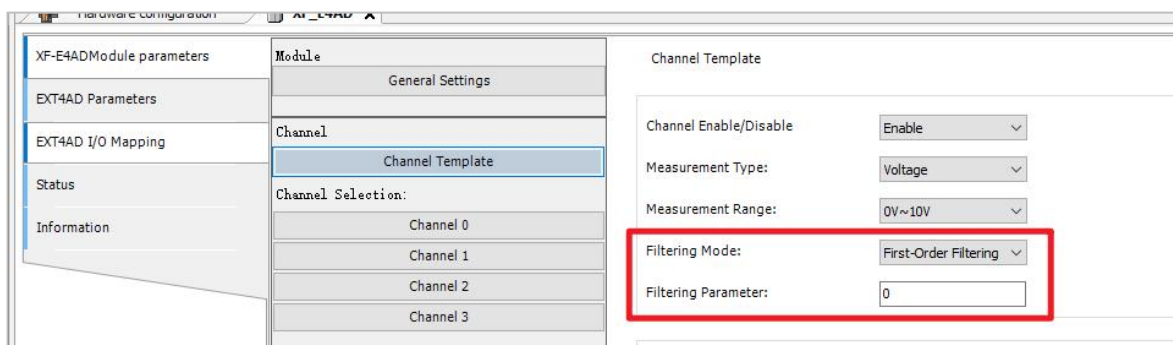

- First order filter

The first-order low-pass filter method combines the current sampling value with the previous filtered output value to produce a filtered result. The filter coefficient, adjustable by the user between 0 and 254, ensures data stability when set lower but may cause delays. A coefficient of 1 delivers optimal filtering performance with maximum stability, while 254 provides minimal filtering. The default setting is 0 (no filtering).

● Average filtering

Time Average	Function actions	Perform A/D conversion based on the set time, then average the total value after removing the maximum and minimum values. The averaged value is stored in the corresponding output buffer. The number of processing cycles within the set time varies according to the number of channels allowed for A/D conversion.
	Set range	2–100ms (default: 2)
Number of times Average	Function actions	Perform A/D conversion based on the set number of times, and average the total value after removing the maximum and minimum values. The averaged value is stored in the corresponding channel variable. The time for storing the average of the averaged values in the corresponding channel variable varies according to the number of channels allowed for A/D conversion.
	Set range	4 to 500 (default 4)
Shift Average per	Function actions	Calculate the average of the specified number of digital output values obtained in each sampling cycle and store it in the corresponding output register/variable. Since moving average processing is performed during each sampling, the latest digital output value can be obtained.
	Set range	2 to 500 (default 2)

● Settable parameter

- ◆ Filter mode (select from dropdown): "First-order filter", "Time average filter", "Frequency average filter", "Moving average filter" (default: First-order filter).
- ◆ Filter parameters (selected via input box): 0~254 (default: 0) for first-order filter mode; 2ms~100ms (default: 2) for time average filter mode; 4~500 (default: 4) for moving average filter mode; 2~500 (default: 2) for moving average filter mode.

■ Overflow setting

When the AD channel sampling exceeds the preset upper or lower limit, the system triggers an alarm log and outputs the preset value.

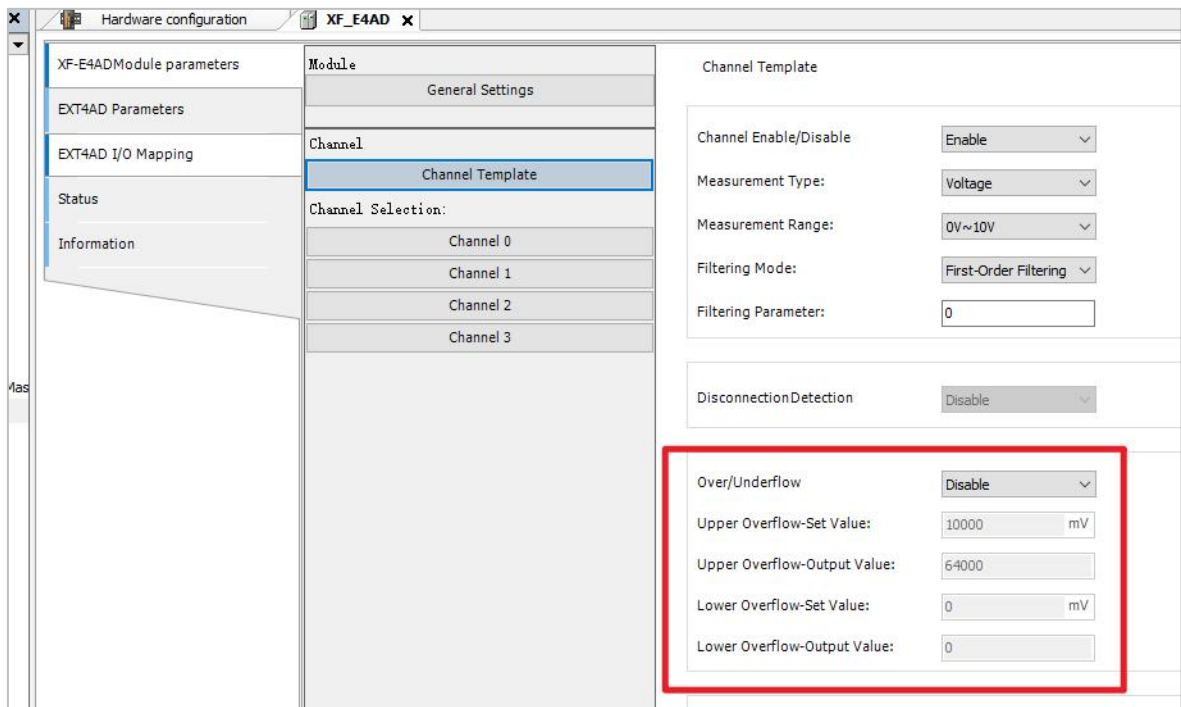

■ Calibration function

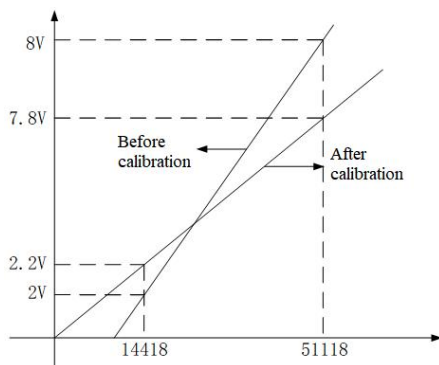
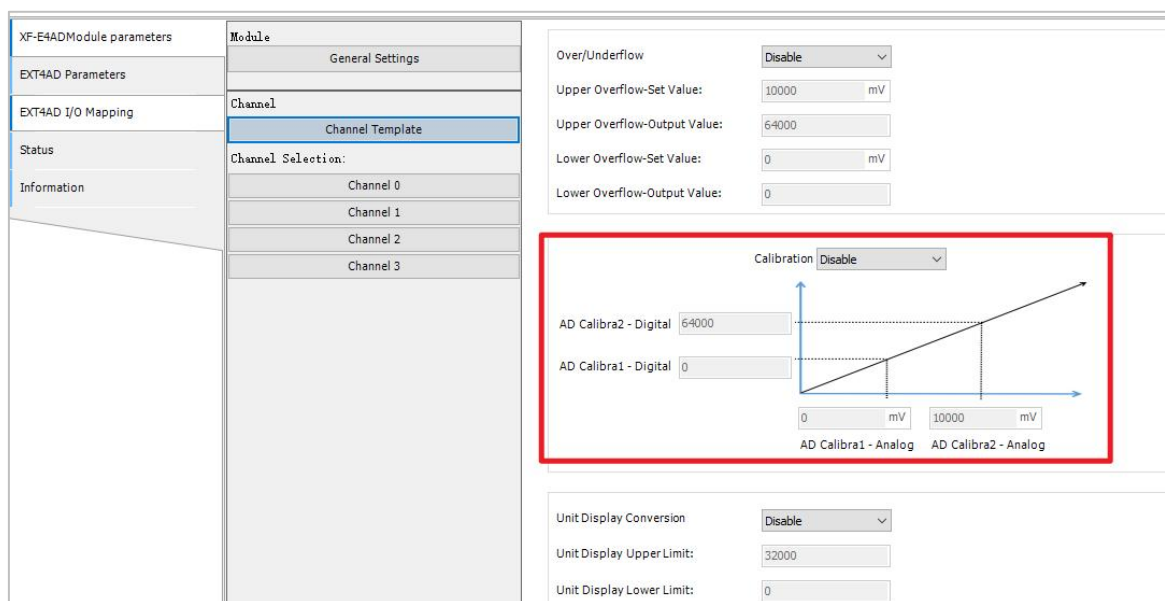

Since the digital values from AD acquisition and conversion may drift from the received analog signals after the product has been in use for some time, customers can calibrate by setting the AD calibration function. The calibration results will be immediately reflected in the proportional scaling value (digital calculation value), allowing them to easily complete the system calibration during startup.

■ Unit display conversion

The screenshot displays the configuration interface for the XF Series Expansion Module. On the left, a navigation pane includes sections for 'XF-E4AD Module parameters', 'EXT4AD Parameters', 'EXT4AD I/O Mapping', 'Status', and 'Information'. The 'Module' section is expanded to show 'General Settings', 'Channel', and 'Channel Selection' (with options for Channel 0, 1, 2, and 3). The 'Channel Template' is selected. The main configuration area is divided into several sections:

- Over/Underflow:** A dropdown menu is set to 'Disable'. Below it are input fields for 'Upper Overflow-Set Value' (10000 mV), 'Upper Overflow-Output Value' (64000), 'Lower Overflow-Set Value' (0 mV), and 'Lower Overflow-Output Value' (0).
- Calibration:** A dropdown menu is set to 'Disable'. Below it is a graph showing a linear relationship between digital and analog values. The y-axis is labeled 'AD Calibra2 - Digital' with a value of 64000. The x-axis is labeled 'AD Calibra1 - Analog' with a value of 0. A second point on the x-axis is labeled 'AD Calibra2 - Analog' with a value of 10000 mV. The graph shows a line starting from the origin and passing through these points.
- Unit Display Conversion:** A dropdown menu is set to 'Disable'. Below it are input fields for 'Unit Display Upper Limit' (32000) and 'Unit Display Lower Limit' (0). This section is highlighted with a red border.

This function can display the analog data directly in the actual output unit required by the customer. The analog output from DA modules primarily serves instruments or sensors. For example, a frequency converter's control signal operates within 0-50Hz, while its analog output ranges from 4-20mA. Conventional DA modules feed this 4-20mA signal to the converter's analog input terminals. To match the actual output frequency, users must manually convert the 0-65535 digital value to 0-50Hz. This can be achieved by configuring the conversion range, enabling the module to automatically translate the analog output into the converter's actual frequency value.

7.3 Analog Output Unit XF-E4DA

7.3.1 Product Overview

The XF-E4DA series analog output expansion module features 4-channel analog outputs supporting current and voltage measurements, compatible with XF/XSF series CPU units and XF series communication coupler units.

- 4-channel analog output;
- The channel switching speed is 60us per channel.
- Maximum error of 0.2%;
- Voltage bipolar output, current output;
- 12mm width design.

■ Module Version

Hardware version	Firmware version	function
H2.0	V2.0	The basic functions are now officially operational for the first time.

7.3.2 Module View

1) Explanation of each section

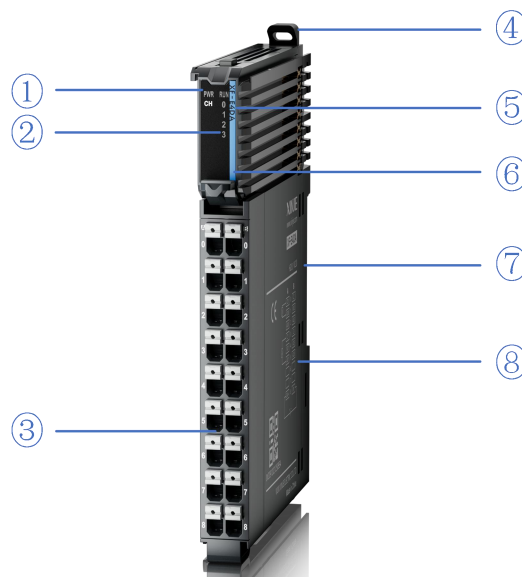

Number	Name	Number	Name
①	System LED indicator lights	②	Channel LED indicator light
③	disconnectable terminal block	④	fastener
⑤	model indication	⑥	Color code for indicator module type
⑦	Module hardware and Firmware version	⑧	hookup

2) System Indicator Light

System indicator light	Meaning	
PWR (green)	extinct	The module is not powered on
	Always on	All external power supplies for the module are functioning normally (backplane bus power and external 24V input).
	Flash 1Hz* ¹	The module section is not functioning properly due to a power supply issue.
RUN (green)	Always on	The module is running normally
	Flash 1Hz* ¹	The module encountered a general error in the log
	extinct	The module encountered a critical error in the log
	10Hz* ²	Modeling communication
	Dual Flash* ³	firmware update



- *1: The duty cycle is 50%, and the frequency is 1Hz, with a square wave.
- *2: The duty cycle is 50%, and the frequency is 10Hz, with a square wave.
- *3: As shown below:

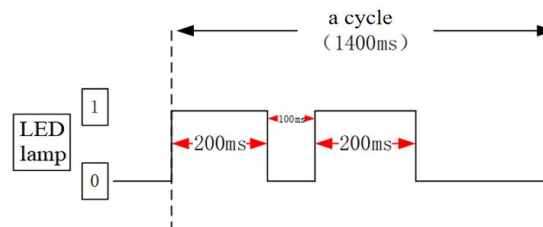

3) Channel indicator light light

Model	Channel indicator light		
XF-E4DA	CH0~CH3	Always on (green)	The channel is enabled and configured correctly
		go out	forbidden channel

4) Color labels

Number	Color		Module type
1		hoar	digital input
2		gray	digital output & digital mixing module
3		wathet	read analogue input
4		mazarine	analog output
5		green	232&485 serial communication
6		rose hermosa	Temperature signal input
7		white	high speed counting
8		purple	pulse output
9		red	repeater power supply

7.3.3 general Specifications

Project		Specifications
Operation temperature	Maximum temperature	55°C
	Minimum temperature	-20°C
Transportation/Storage Temperature	Maximum temperature	70°C
	Minimum temperature	-40°C
Environmental humidity (including operation/storage)	superior limit	95%
	lower limit	10%
Levels of protection		IP20
Anti-vibration		Complies with IEC61131-2 under intermittent vibration (frequency 5-9Hz, constant amplitude 3.5mm peak displacement) and (frequency 9-150Hz, constant acceleration 1.0g peak acceleration) The continuous shock vibration (5-9Hz, half amplitude 1.75mm displacement) and (9-150Hz, constant acceleration 0.5g, constant frame amplitude) Scan 10 times in X, Y, and Z directions
Shock resistance		Complies with IEC61131-2 standard Impact intensity of 15G (peak) was applied for 11ms on each of three mutually perpendicular axes, with 3 impacts per axis (total 18 impacts).
Operating environment		Non-corrosive gases
Operating altitude		0-2000 meters
Overvoltage class		II: Complies with IEC61131-2
Pollution level		2; Complies with IEC61131-2
Anti-interference EMC		Complies with IEC 61131-2 and IEC 61000-6-4 Type B
Relevant certifications		CE

7.3.4 Technical Specifications

7.3.4.1 Module Performance

Project		Specifications
Outgoing channel		4
Analog output range (rated)	Range of output voltage	0V~5V(0~64000) 0V~10V(0~64000) -5V~5V(-32000~32000) -10V~10V(-32000~32000) 1V~5V(12800~64000) External load resistance: 2KΩ to 1MΩ
	Output current range	0mA~20mA(0~64000) 4mA~20mA(12800~64000) The external load resistance is less than 500Ω
Maximum output Outside the range	Output voltage	DC±15V
	Output current	-40~40mA
Conversion rate		60us/CH
Response time		60us
Resolution ratio		1/64000(16Bit)
Module availability	Rated input	DC24V±10%, 150mA
Electric power supply	Protect	reverse protection
Error	Room temperature: 25°c ± 5°c	±0.1%(25±5 °C)
	Full temperature range: -20 to 55°c	±0.2%
Insulate		Channel is not isolated, power is isolated
Module dissipation		0.8W (internal backplane) + 1.2W (external input)
Module weight		80g

7.3.4.2 Module Conversion Diagram

1) Voltage

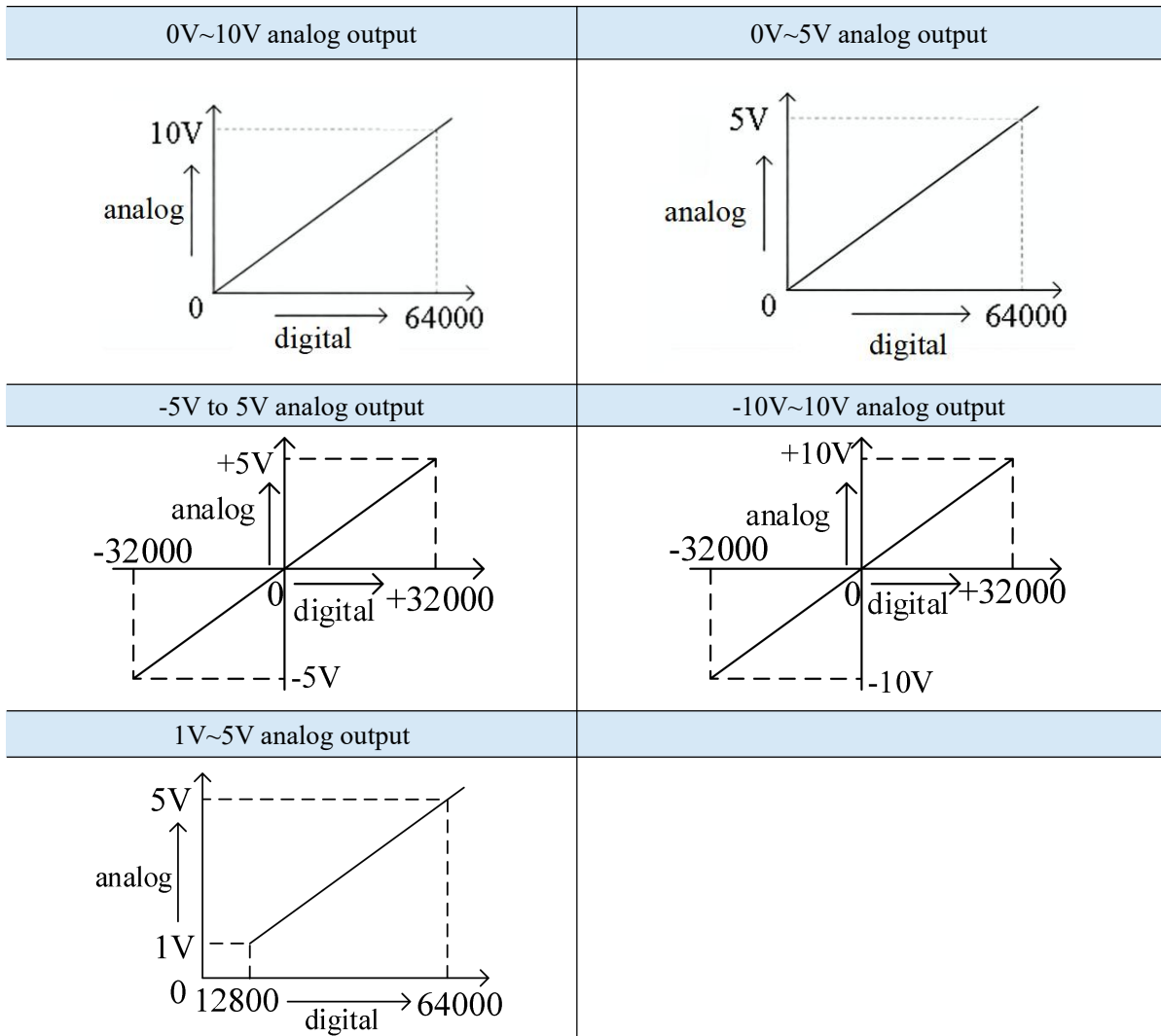

2) Current

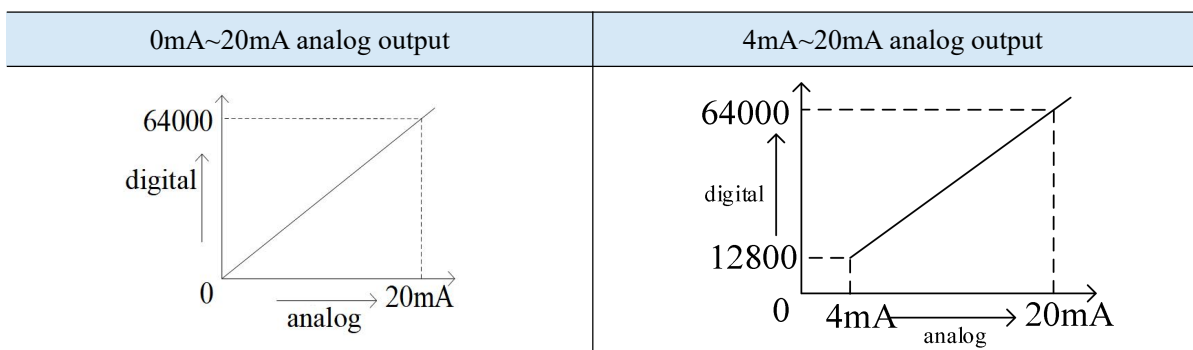

7.3.5 Installation & Wiring

7.3.5.1 Appearance dimensions

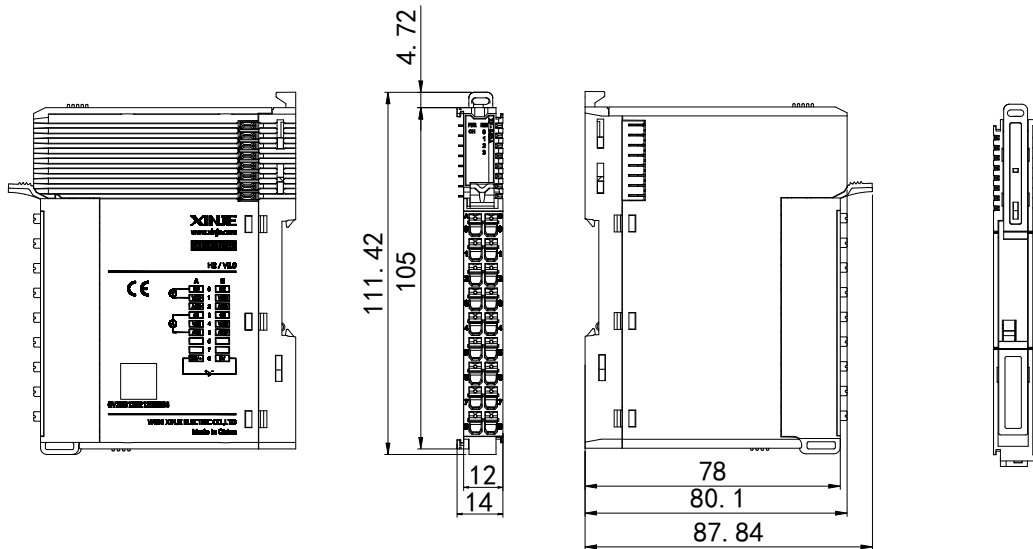

(unit: mm)

7.3.5.2 Terminal Definitions & Wiring

1) Terminal definition

XF-E4DA				
Meaning	A terminal	Terminal arrangement	B terminal	Meaning
CH0-Common output terminal	0		0	CH2-output common terminal
CH0-DA Analog Voltage Output Terminal	1		1	CH2-DA analog voltage output terminal
CH0-DA analog current output terminal	2		2	CH2-DA analog current output terminal
CH1-output common terminal	3		3	CH3-output common terminal
CH1-DA Analog Voltage Output Terminal	4		4	CH3-DA Analog Voltage Output Terminal
CH1-DA Analog Current Output Terminal	5		5	CH3-DA analog current output terminal
empty	6		6	empty
empty	7		7	empty
The external module receives a	8		8	The external module is powered

XF-E4DA				
Meaning	A terminal	Terminal arrangement	B terminal	Meaning
24V positive power supply.				by a 24V negative power supply.

2) External wiring

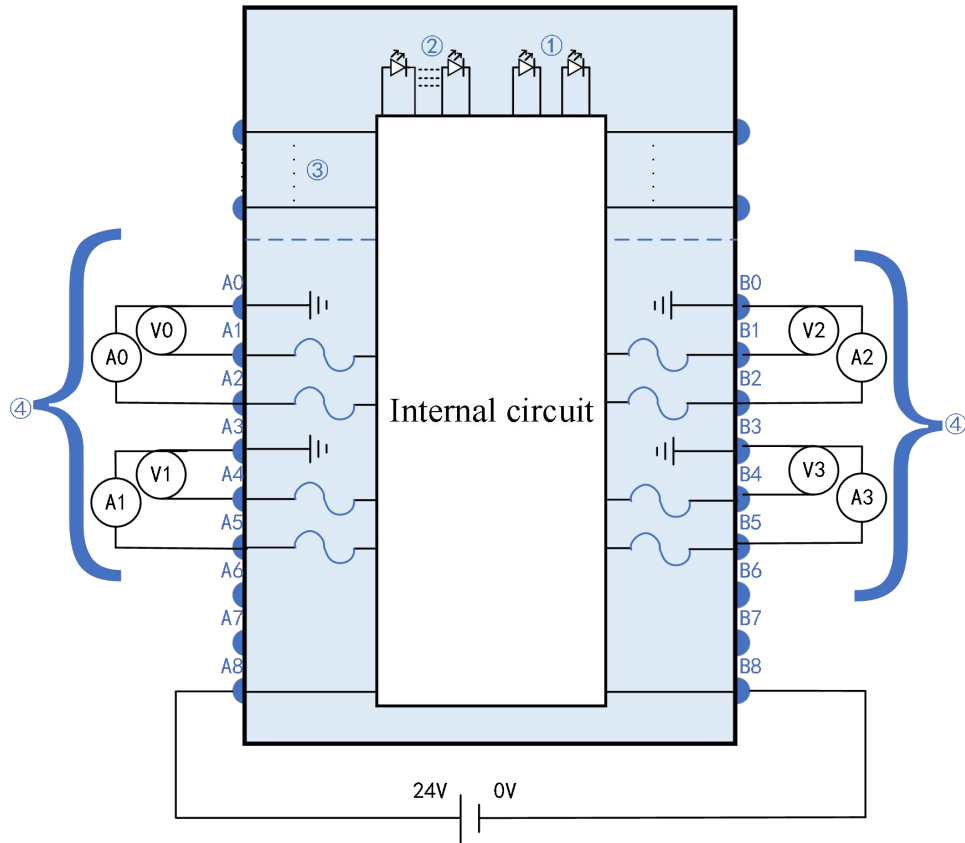

- ① System Indicator Light
- ② Channel indicator light
- ③ backplane bus
- ④ Output channel & wiring light

7.3.5.3 Installation Method

1) Installation requirements

The module is mounted using DIN rails that comply with IEC 60715 standards (35mm wide, 1mm thick). The dimensions are shown in the figure below, with measurements in millimeters.

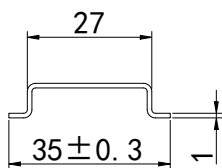

Attention

When the module is installed on a DIN rail not recommended above, the DIN rail latch may fail to lock properly.

2) Installation Steps

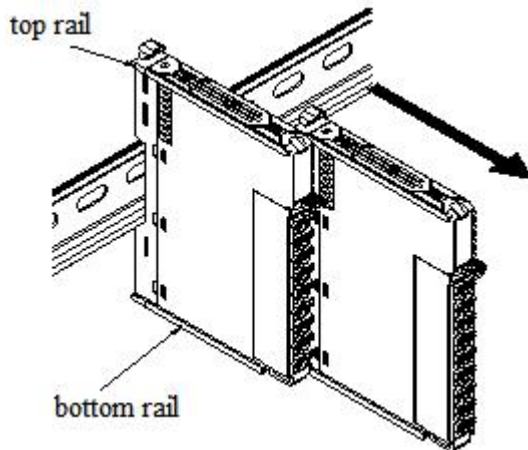

1. The IO modules are assembled by sliding along the top and bottom rails, as shown in the left figure.

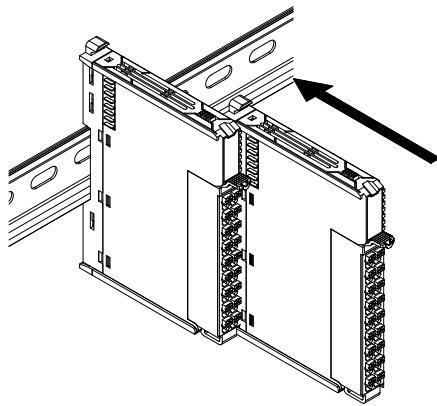

2. The module is mounted on the guide rail. During installation, align the module with the DIN guide rail and press it in the direction indicated by the arrow. A clear clicking sound will be heard when the module is properly secured, as shown in the left image.

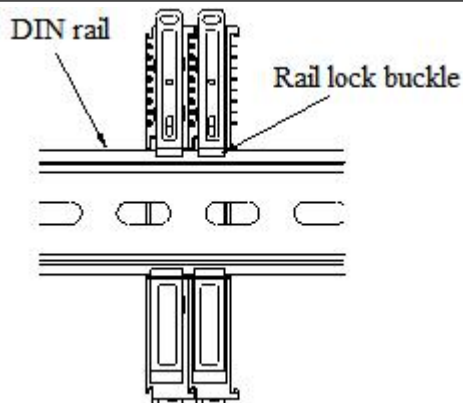

3. After module installation, the latch will automatically lower to lock. If it fails to move down, press the top of the latch downward to ensure proper installation.

3) Disassembly steps

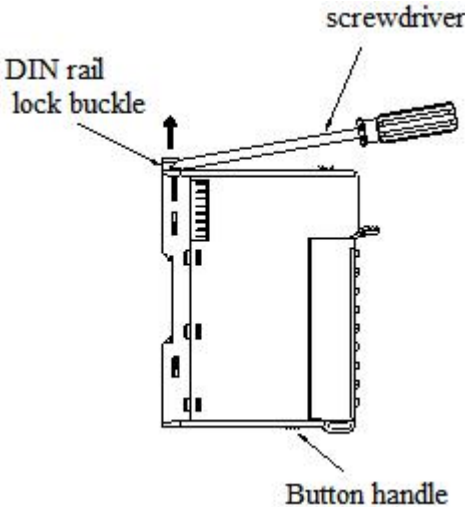

1. Use a screwdriver or similar tool to pry up the guide rail lock, as shown in the left image:

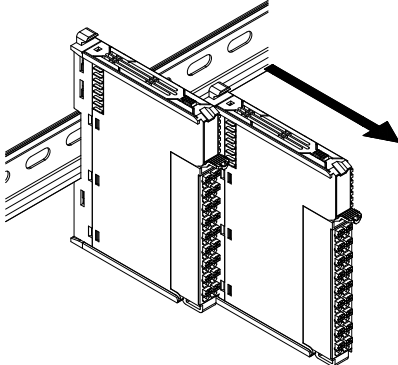

2. Pull the module straight forward from the buckle position (the raised part), then press down the top of the buckle as shown in the left image.

7.3.5.4 Installation Environment

This product supports four installation orientations: horizontal, vertical, top-mounted on electrical cabinets, and bottom-mounted. Horizontal installation is recommended. The cooling system utilizes natural convection. To ensure proper ventilation and heat dissipation while maintaining sufficient wiring clearance, a minimum clearance must be maintained around the product, as shown in the figure below.

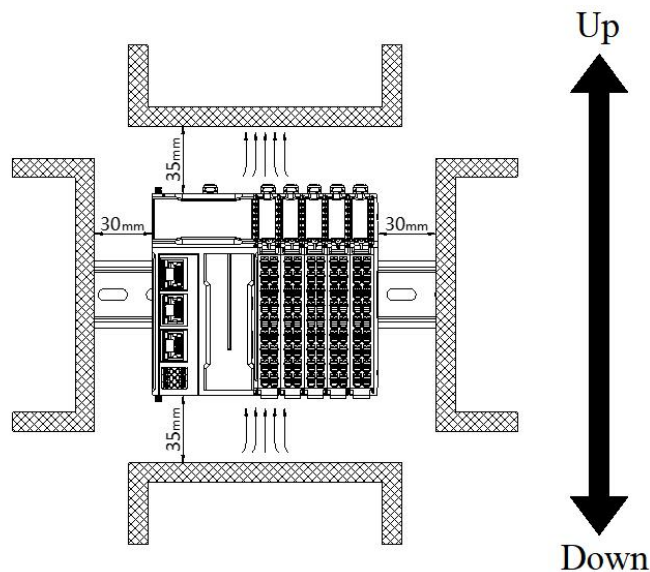



If the product is surrounded by high-temperature heat source equipment (heaters, transformers, high-resistance components, etc.), maintain a minimum clearance of 100mm between the product and such equipment.

7.3.5.5 Equipment Wiring

When wiring the module, its connectors must meet the following requirements:

Suitable wire gauge	
National standard/mm ²	American-Standard /AWG
0.3	22
0.5	20
0.75	18
1.0	18
1.5	16

If using other wire-type terminal lugs, press them onto the stranded wire as shown in the figure below for shape and size requirements.

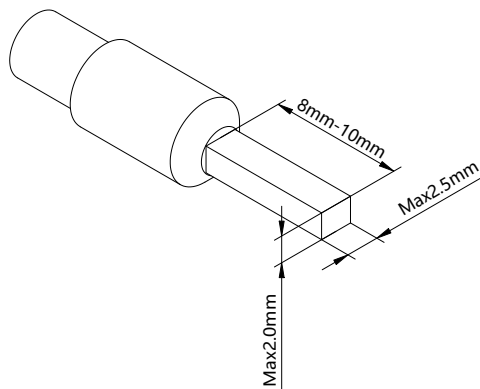

7.3.6 Parameters and Mapping Addresses

Name	Type	Explanation
XF_E4DA	Stuct	4-channel output module
CH0	DINT	Channel 0 output value
CH1	DINT	Channel 1 output value
CH2	DINT	Channel 2 output value
CH3	DINT	Channel 3 output value
ErrCode_module	WORD	Module-level error code
ErrCode_CH	DWORD	Channel level error code

- Error code parameter

Module-level error code (ErrCode_module)		
Bit position	meaning	Error level
0	The 24V input power of the module is abnormal.	Critical
2	An internal module error occurred and the user layer cannot fix it	Critical
3	Version mismatch	Critical
4	ADC/DAC read/write failure	Critical

■ Configuration parameter

Parameter	Type	Channel	Meaning	Remarks
Power_Detection	Enumeration of BYTE	--	Power supply detection	0: Close 1: Open
CH0 enable disable	BYTE	channel 0	Enable/Disable channel	0: Close 1: Open
CH0 Output Range select	BYTE		Output type and range	0: 0~10V 1: 0~5V 2: -10~10V 3: -5~5V 4: 1~5V 5: 0~20mA 6: 4~20mA
output hold the previous value or preset value in the stopped state	Enumeration of BYTE		The output remains at the previous value or preset value in STOP state	0: Keep the previous value; 1: Set value
CH0 default value	DINT		default	-32000~64000
calibrate enable disable	Enumeration of BYTE		Enable/Disable calibration	0: Close 1: Open
CH0 Calibration1 Analog	INT		Calibrate 1 analog signal	output voltage 0~10V:
CH0 Calibration1 Numerical	DINT		Calibrate 1 digital quantity	Analog range: 0~10000mV Digital range: 0 to 64000
CH0 Calibration2 Analog	INT		Calibrate the 2 analog signals.	0~5V: Analog range: 0~5000mV Digital range: 0 to 64000
CH0 Calibration2 Numerical	DINT		Calibrate 2 digital quantities	-10~10V: Analog range: -10000 to 10000 mV Digital range: -32000 to 32000 -5~5V: Analog range: -5000 to 5000mV Digital range: -32000 to 32000 1~5V: Analog range: 1000mV~5000mV Digital range: 12800 to 64000 output current 0~20mA:

Parameter	Type	Channel	Meaning	Remarks
				Analog range: 0~20000μA Digital range: 0 to 64000 4~20mA: Analog range: 4000-20000μA Digital range: 12800-64000
unit display conversion enable disable	Enumeration of BYTE		Enable/Disable unit display conversion	0: Close 1: Open
CH0 UpperLimit	DINT		Unit display conversion upper limit	Range: -100000000 to 100000000 and make the unit conversion result (upper limit-lower limit)> 0
CH0 LowerLimit			Lower limit of unit conversion	
CH1 enable disable	Enumeration of BYTE		Enable/Disable channel	0: Close 1: Open
CH1 Output Range select	BYTE		Output type and range	0:0~10V 4:1~5V 1:0~5V 5:0~20mA 2:-10~10V 6:4~20mA 3:-5~5V
output hold the previous value or preset value in the stopped state	Enumeration of BYTE		The output remains at the previous value or preset value in STOP state	0: Keep the previous value; 1: Set value
CH1 default value	DINT		default	-32000~64000
calibrate enable disable	Enumeration of BYTE		Enable/Disable calibration	0: Close 1: Open
CH1 Calibration1 Analoc	INT	channel 1	Calibrate 1 analog signal	output voltage 0~10V:
CH1 Calibration1 Numerical	DINT		Calibrate 1 digital quantity	Analog range: 0~10000mV Digital range: 0 to 64000
CH1 Calibration2 Analog	INT		Calibrate the 2 analog signals.	0~5V: Analog range: 0~5000mV Digital range: 0 to 64000
CH1 Calibration2 Numerical	DINT		Calibrate 2 digital quantities	-10~10V: Analog range: -10000 to 10000 mV Digital range: -32000 to 32000
				-5~5V: Analog range: -5000 to 5000mV Digital range: -32000 to 32000
				1~5V: Analog range: 1000mV~5000mV Digital range: 12800 to 64000

Parameter	Type	Channel	Meaning	Remarks
				output current 0~20mA: Analog range: 0~20000μA Digital range: 0 to 64000 4~20mA: Analog range: 4000-20000μA Digital range: 12800-64000
unit display conversion enable disable	Enumeration of BYTE		Enable/Disable unit display conversion	0: Close 1: Open
CH1 UpperLimit	DINT		Unit display conversion upper limit	Range: -100000000 to 100000000 and make the unit conversion result (upper limit-lower limit)> 0
CH1 LowerLimit		Lower limit of unit conversion		
CH2 enable disable	Enumeration of BYTE		Enable/Disable channel	0: Close 1: Open
CH2 Output Range select	BYTE		Output type and range	0: 0~10V 4: 1~5V 1: 0~5V 5: 0~20mA 2: -10~10V 6: 4~20mA 3: -5~5V
output hold the previous value or preset value in the stopped state	Enumeration of BYTE		The output remains at the previous value or preset value in STOP state	0: Keep the previous value; 1: Set value
CH2 default value	DINT		default	-32000~64000
calibrate enable disable	Enumeration of BYTE		Enable/Disable calibration	0: Close 1: Open
CH2 Calibration1 Analoc	INT	channel 2	Calibrate 1 analog signal	output voltage 0~10V:
CH2 Calibration1 Numerical	DINT		Calibrate 1 digital quantity	Analog range: 0~10000mV Digital range: 0 to 64000
CH2 Calibration2 Analog	INT		Calibrate the 2 analog signals.	0~5V: Analog range: 0~5000mV Digital range: 0 to 64000
CH2 Calibration2 Numerical	DINT		Calibrate 2 digital quantities	-10~10V: Analog range: -10000 to 10000 mV Digital range: -32000 to 32000
				-5~5V: Analog range: -5000 to 5000mV Digital range: -32000 to 32000
				1~5V: Analog range:

Parameter	Type	Channel	Meaning	Remarks
				1000mV~5000mV Digital range: 12800 to 64000 output current 0~20mA: Analog range: 0~20000μA Digital range: 0 to 64000 4~20mA: Analog range: 4000-20000μA Digital range: 12800-64000
unit display conversion enable disable	Enumeration of BYTE		Enable/Disable unit display conversion	0: Close 1: Open
CH2 UpperLimit	DINT		Unit display conversion upper limit	Range: -100000000 to 100000000 and make the unit conversion result (upper limit-lower limit)> 0
CH2 LowerLimit		Lower limit of unit conversion		
CH3 enable disable	Enumeration of BYTE		Enable/Disable channel	0: Close 1: Open
CH3 Output Range select	BYTE		Output type and range	0: 0~10V 4: 1~5V 1: 0~5V 5: 0~20mA 2: -10~10V 6: 4~20mA 3: -5~5V
output hold the previous value or preset value in the stopped state	Enumeration of BYTE		The output remains at the previous value or preset value in STOP state	0: Keep the previous value; 1: Set value
CH3 default value	DINT		default	-32000~64000
calibrate enable disable	Enumeration of BYTE		Enable/Disable calibration	0: Close 1: Open
CH3 Calibration1 Analoc	INT	channel 3	Calibrate 1 analog signal	output voltage 0~10V:
CH3 Calibration1 Numerical	DINT		Calibrate 1 digital quantity	Analog range: 0~10000mV Digital range: 0 to 64000
CH3 Calibration2 Analog	INT		Calibrate the 2 analog signals.	0~5V: Analog range: 0~5000mV Digital range: 0 to 64000
CH3 Calibration2 Numerical	DINT		Calibrate 2 digital quantities	-10~10V: Analog range: -10000 to 10000 mV Digital range: -32000 to 32000
				-5~5V: Analog range: -5000 to 5000mV Digital range: -32000 to 32000

Parameter	Type	Channel	Meaning	Remarks
				1~5V: Analog range: 1000mV~5000mV Digital range: 12800 to 64000 output current 0~20mA: Analog range: 0~20000μA Digital range: 0 to 64000 4~20mA: Analog range: 4000-20000μA Digital range: 12800-64000
unit display conversion enable disable	Enumeration of BYTE		Enable/Disable unit display conversion	0: Close 1: Open
CH3 UpperLimit	DINT		Unit display conversion upper limit	Range: -100000000 to 100000000 and make the unit conversion result (upper limit-lower limit)> 0
CH3 LowerLimit			Lower limit of unit conversion	

7.3.7 Functions and Settings

■ Enable/Disable channel

Enable or disable AD sampling channels to save module sampling time.

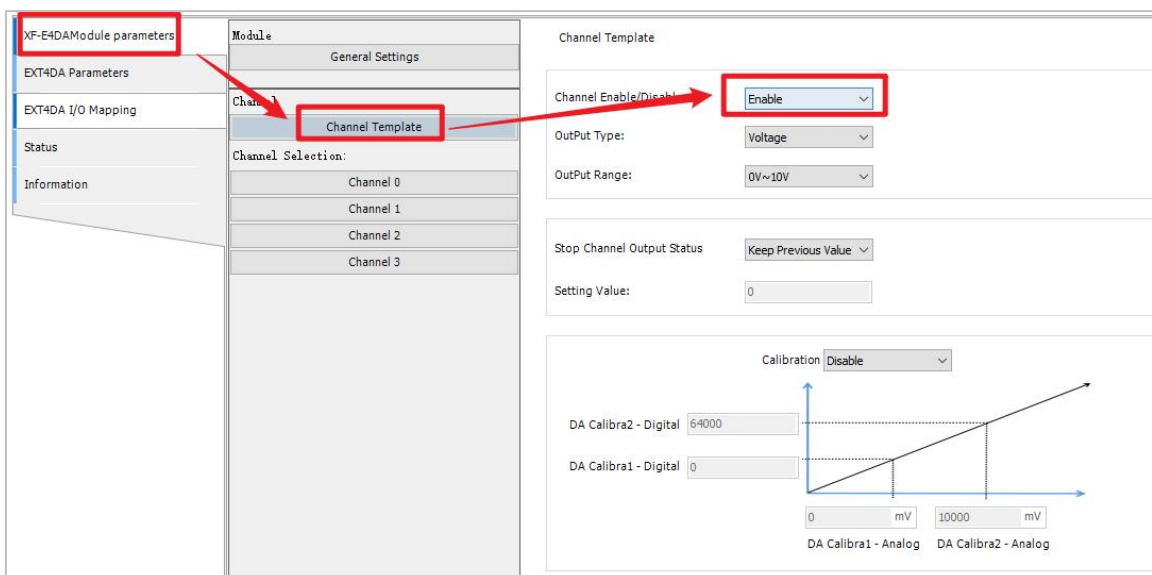

Parameters can be set	Enable or disable (After disabling, you cannot configure subsequent software functions for the corresponding channel)
Default parameters	start using
Matters need attention	Each channel has a conversion time of 60μs. The total time equals the

switching speed multiplied by the number of active channels. To reduce the module's total conversion time, you can disable the channel if it is not in use.

■ Output type/Range

You can choose different output types and ranges.

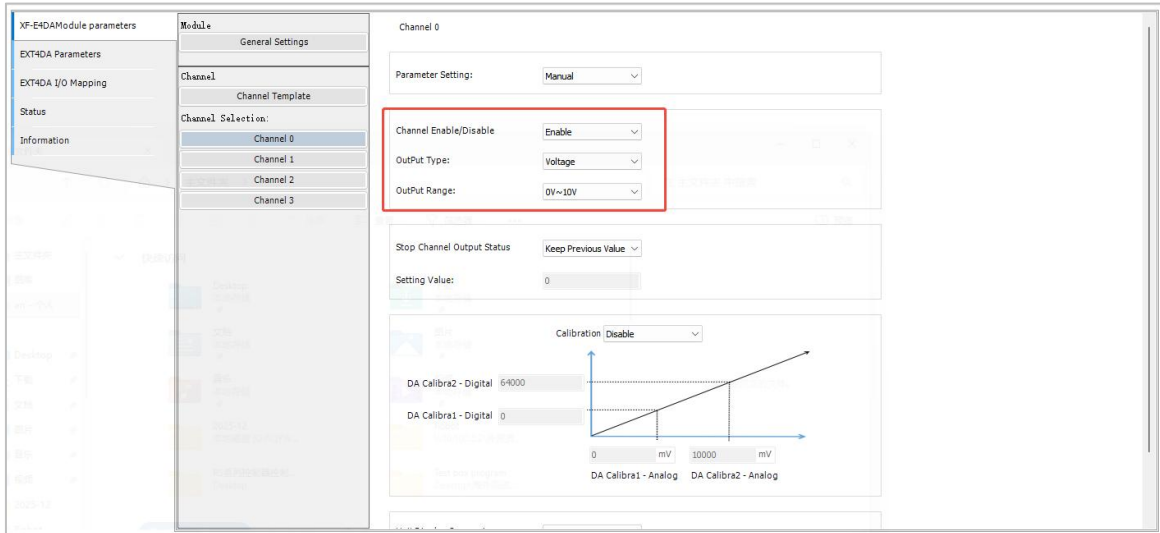

Parameters can be set	The table below shows configurable parameters: voltage and current
Default parameters	voltage
Voltage measurement range	0V~5V,0V~10V,-5V~5V,-10V~10V,1V~5V Default: 0V~10V
current measurement range	0mA~20mA, 4mA~20mA

■ Module power detection

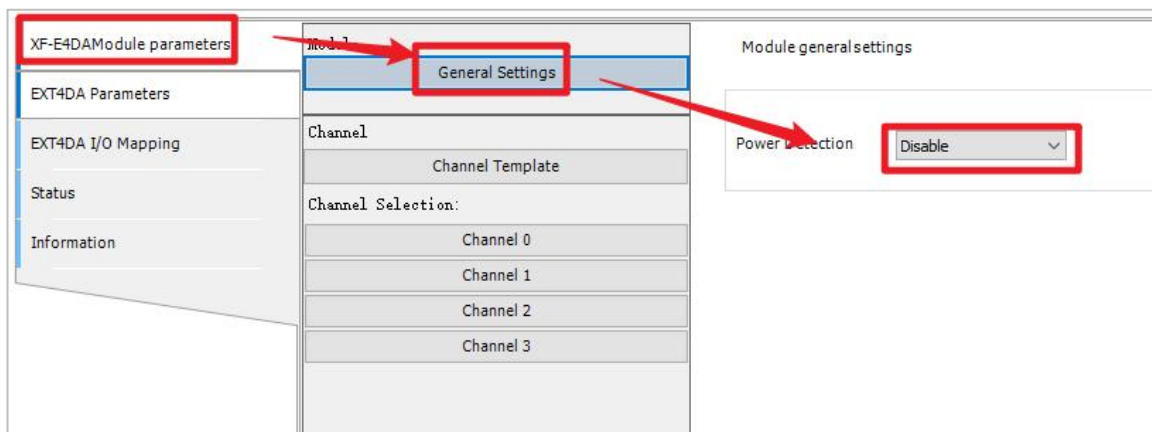

- Check if the external 24V power supply for the detection module is normal:
- Normal: The module is functioning properly.
- Error: The module channel is unavailable but can be configured, set up, and scanned.
- Parameters: Enable, disable (disabled by default).

■ STOP output

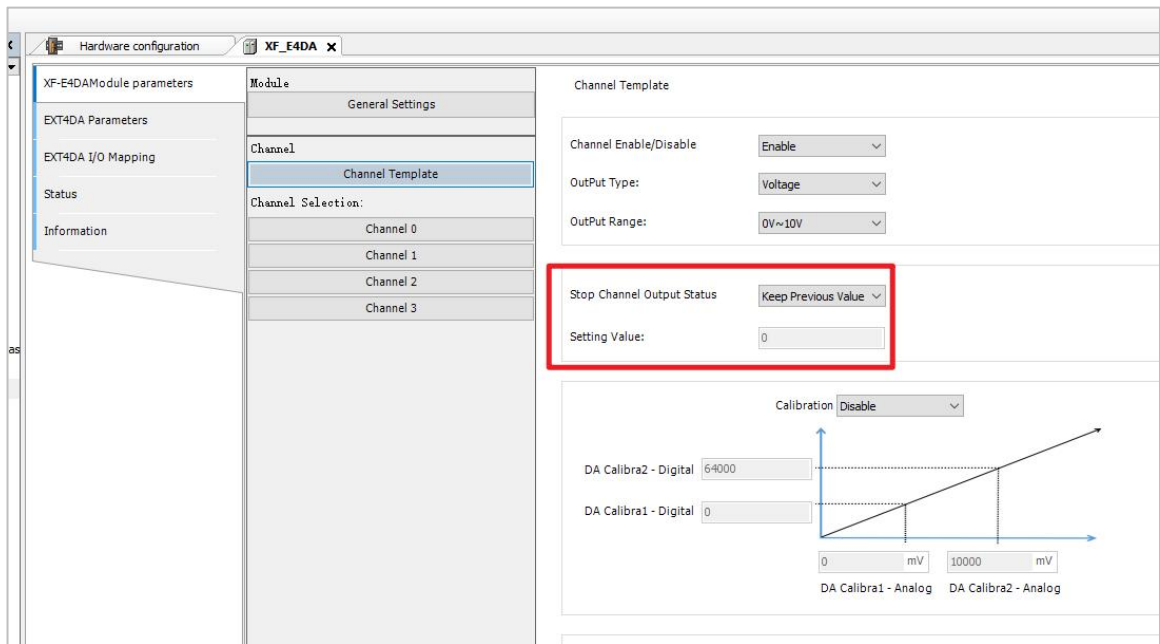

- When the CPU unit is in STOP mode or abnormal error mode, the corresponding DA channel of the module outputs according to the set parameters.
- Parameters: Keep previous value, Set value (default: Keep previous value).

■ Calibration function

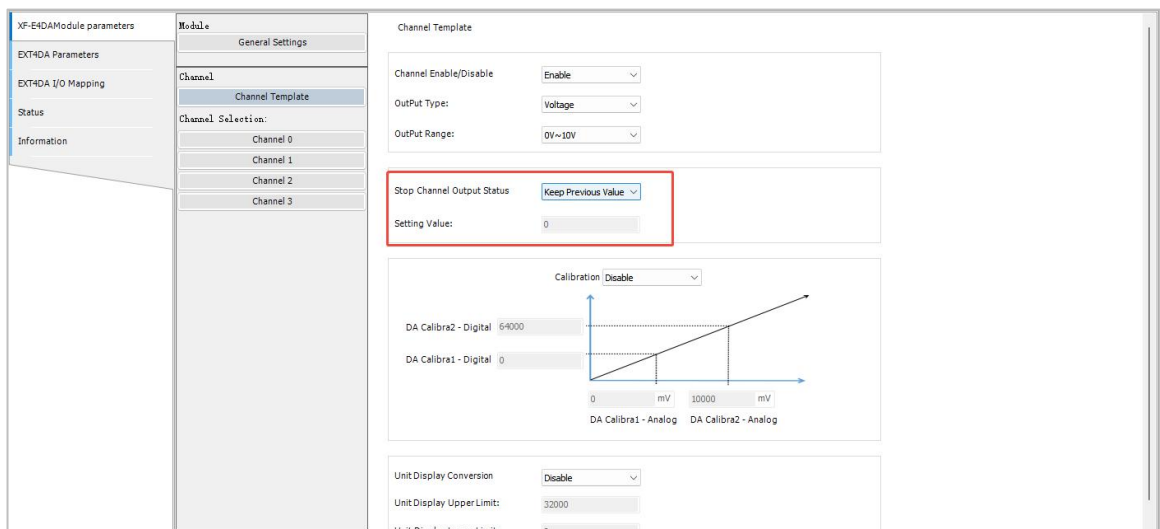

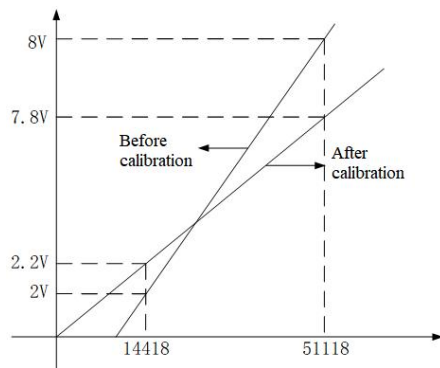

When products are shipped or after prolonged use, the analog output from DA conversion may deviate from the preset digital values. Customers can calibrate DA offset by adjusting the proportional scaling value (digital calculation value), enabling effortless system startup calibration.

For example, DA1's analog output is configured to 0-10V. When the output channel is set to 51118, the voltage output is 8V; when set to 14418, the output voltage is 2V. To calibrate DA1, set the analog setting to 8000mV, the digital setting to 51118, the analog setting to 2000mV, and the digital setting to 14418. This configuration enables the calibration function.

■ Unit display conversion

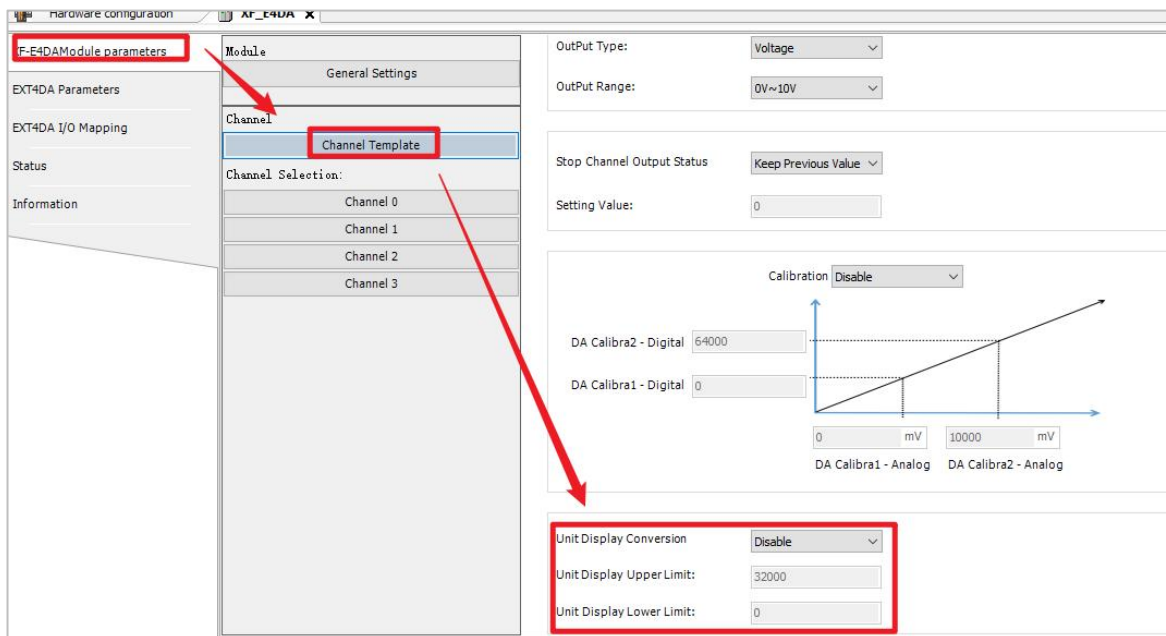

This function can display the analog data directly in the actual output unit required by the customer.

The analog output from DA modules primarily serves instruments or sensors. For example, a frequency converter's control signal operates within 0-50Hz, while its analog output ranges from 4-20mA. Conventional DA modules feed this 4-20mA signal to the converter's analog input terminals. To match the actual output frequency, users must manually convert the 0-65535 digital value to 0-50Hz. This can be achieved by configuring the conversion range, enabling the module to automatically translate the analog output into the converter's actual frequency value.

7.4 Analog Input current unit XF-E8AD-A

7.4.1 Product Overview

The XF-E8AD-A series analog Input current expansion module features 8-channel analog Input current, compatible with XF/XSF series CPU units and XF series communication coupler units.

- 8-channel analog Input current;
- The channel switching speed is 100us/channel.
- Maximum error of 0.2%;
- 12mm width design.

■ Module Version

Hardware version	Firmware version	function
H2.0	V2.0	The basic functions are now officially operational for the first time.

7.4.2 Module View

1) Explanation of each section

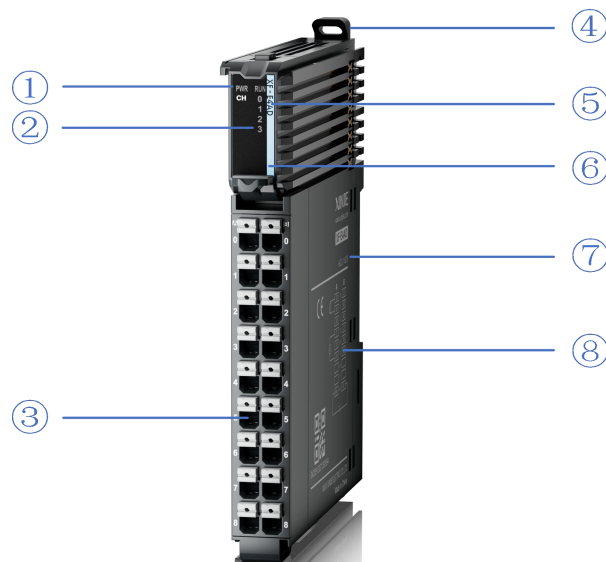

Number	name	Number	name
①	System LED indicator lights	②	Channel LED indicator light
③	disconnectable terminal block	④	fastener
⑤	model indication	⑥	Color code for indicator module type
⑦	Module hardware and Firmware version	⑧	hookup

2) System Indicator Light

System Indicator Light	meaning	
PWR (green)	extinct	Module not powered on (backplane bus)
	Always on	All external power supplies for the module are functioning normally (backplane bus power and external 24V input).
	Flash 1Hz*1	Partial module power supply is abnormal and cannot operate normally (external)
RUN (green)	Always on	The module is running normally
	Flash 1Hz*1	The module encountered a general error in the log
	extinct	The module encountered a critical error in the log
	10Hz*2	Modeling communication
	Dual Flash*3	firmware update



- *1: The duty cycle is 50%, and the frequency is 1Hz, with a square wave.
- *2: The duty cycle is 50%, and the frequency is 10Hz, with a square wave.
- *3: As shown below:

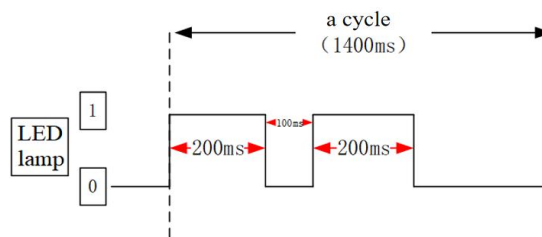

3) Channel indicator light light

Model	Channel indicator light		
XF-E8AD-A	CH0~CH7	Always on (green)	The channel is enabled and configured correctly
		10Hz Flash	The channel has an error message
		go out	forbidden channel

4) Color labels

Number	Color		Module type
1		hoar	digital input
2		gray	digital output & digital mixing module
3		wathet	read analogue input
4		mazarine	analog output
5		green	232&485 serial communication
6		rose hermosa	Temperature signal input
7		white	high speed counting
8		purple	pulse output
9		red	repeater power supply

7.4.3 General Specifications

Project		Specifications
Operation temperature	Maximum temperature	55°C
	Minimum temperature	-20°C
Transportation/Storage Temperature	Maximum temperature	70°C
	Minimum temperature	-40°C
Environmental humidity (including operation/storage)	superior limit	95%
	lower limit	10%
Levels of protection		IP20
Anti-vibration		Complies with IEC61131-2 under intermittent vibration (frequency 5-9Hz, constant amplitude 3.5mm peak displacement) and (frequency 9-150Hz, constant acceleration 1.0g peak acceleration) The continuous shock vibration (5-9Hz, half amplitude 1.75mm displacement) and (9-150Hz, constant acceleration 0.5g, constant frame amplitude) Scan 10 times in X, Y, and Z directions
Shock resistance		Complies with IEC61131-2 standard Impact intensity of 15G (peak) was applied for 11ms on three mutually perpendicular axes, with 3 impacts per axis (total 18 impacts).
Operating environment		Non-corrosive gas
Operating altitude		0-2000 meters
Overvoltage class		II: Complies with IEC61131-2
Pollution level		2; Complies with IEC61131-2
Anti-interference EMC		Complies with IEC 61131-2 and IEC 61000-6-4 Type B
Relevant certifications		CE

7.4.4 Technical Specifications

7.4.4.1 Module Performance

Project		Specifications
Input channel		8
Analog input range (specified)	Input range	0mA~20mA (0~64000) 4mA~20mA (12800~64000) -20mA~20mA (-32000~32000)

Project		Specifications
		The impedance is approximately 120Ω.
Maximum input range	Input current	-40~40mA
Conversion rate		100μs/CH, 250μs/8 channels
Resolution ratio		1/64000(16Bit)
Module power supply Source	Rated input	DC24V±10%, 150mA
	Protect	reverse protection
Error	Room temperature: 25°C ± 5°C	±0.1%(25±5 °C)
	Full temperature range: -20 to 55°C	±0.2%
Insulate		Channel is not isolated, power is isolated
Module dissipation		0.73W (internal backplane) + 0.7W (external input)
Module weight		80g

7.4.4.2 Module Conversion Diagram

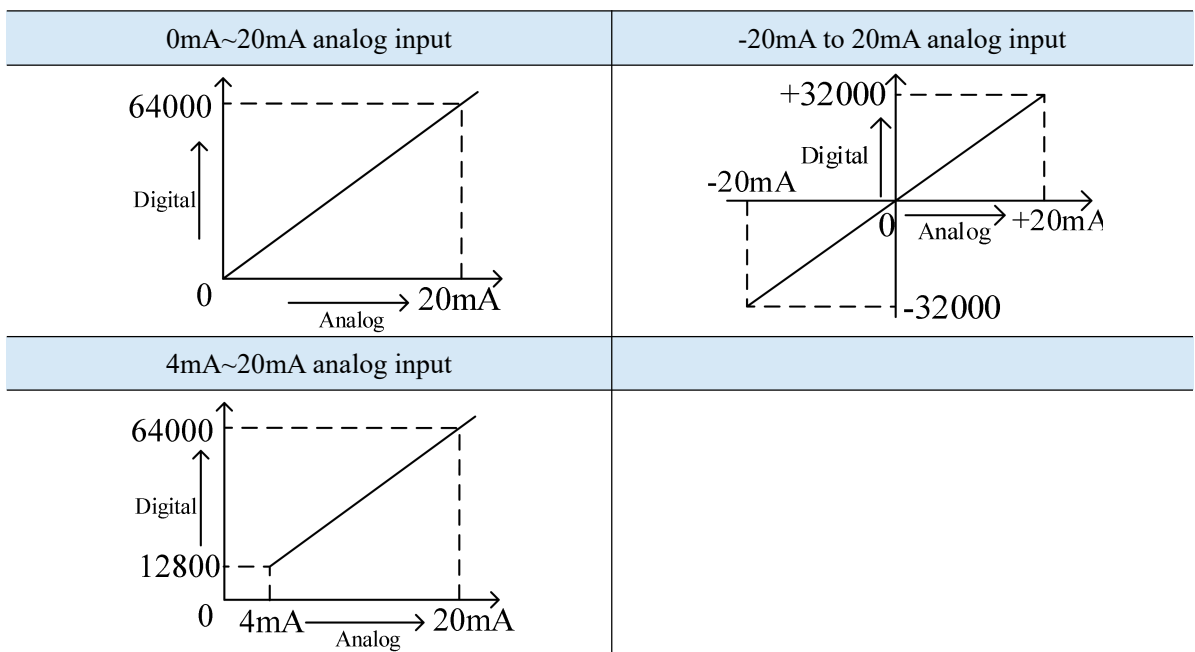

7.4.5 Installation & Wiring

7.4.5.1 Appearance dimensions

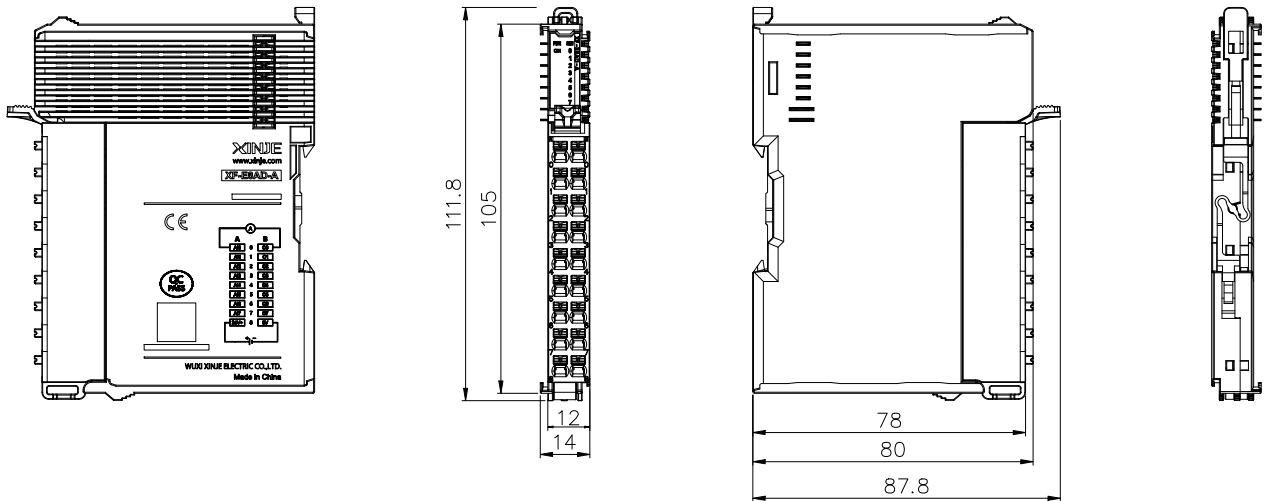

(unit :mm)

7.4.5.2 Terminal Definitions & Wiring

1) Terminal definition

XF-E8AD-A				
meaning	A terminal	terminal arrangement	B terminal	meaning
CH0-AD analog Input current terminal	0		0	CH0-Common input terminal
CH1-AD Analog Input current Terminal	1		1	CH1-Common input terminal
CH2-AD analog Input current terminal	2		2	CH2-Input Common Terminal
CH3-AD analog Input current terminal	3		3	CH3-Input Common Terminal
CH4-AD analog Input current terminal	4		4	CH4-Input common terminal
CH5-AD analog Input current terminal	5		5	CH5-Input common terminal
CH6-AD analog Input current terminal	6		6	CH6-Input common terminal
CH7-AD Analog Input current Terminal	7		7	CH7-Input common terminal

XF-E8AD-A				
meaning	A terminal	terminal arrangement	B terminal	meaning
The external module receives a 24V positive power supply.	8		8	The external module is powered by a 24V negative power supply.

2) External wiring

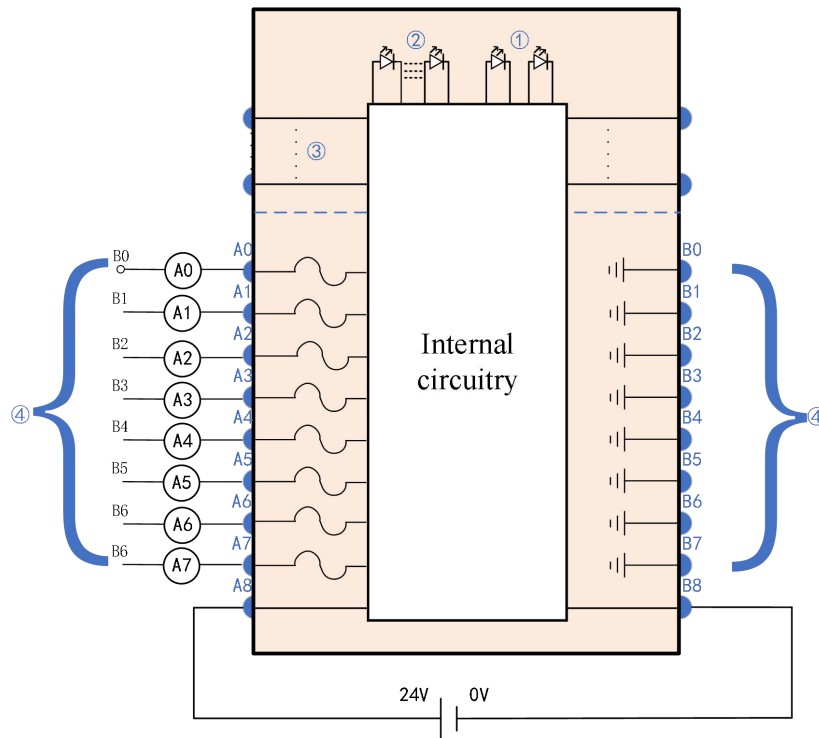

- ① System Indicator Light ② Channel indicator light ③ backplane bus ④ Input channel & wiring light

7.4.5.3 Installation Method

1) Installation requirements

The module is mounted using DIN rails that comply with IEC 60715 standards (35mm wide, 1mm thick). The dimensions are shown in the figure below, with measurements in millimeters.

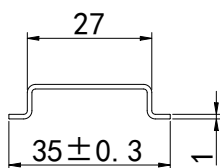

Attention

When the module is installed on a DIN rail not recommended above, the DIN rail latch may fail to lock properly.

2) Installation Steps

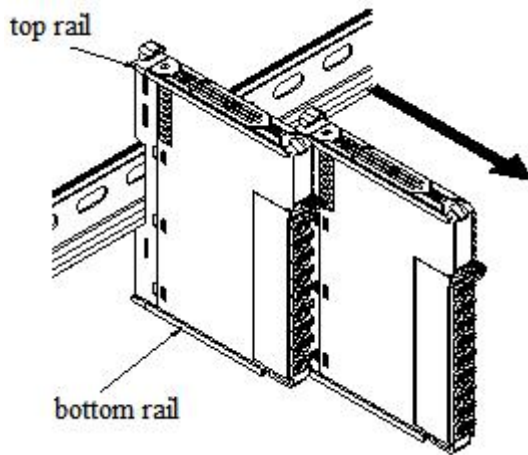

1. The IO modules are assembled by sliding along the top and bottom rails, as shown in the left figure.

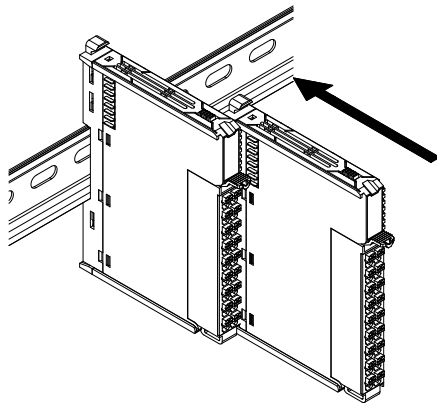

2. The module is mounted on the guide rail. During installation, align the module with the DIN guide rail and press it in the direction indicated by the arrow. A clear click sound will be heard when the module is properly secured, as shown in the left image.

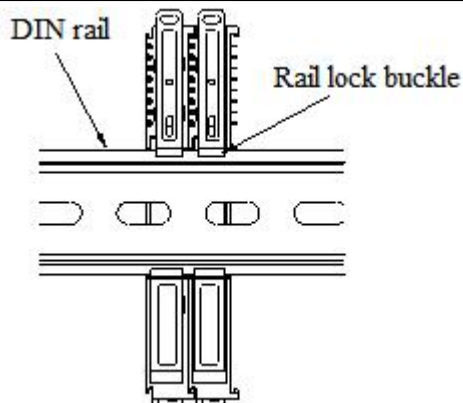

3. After module installation, the latch will automatically lower to lock. If it fails to move down, press the top of the latch downward to ensure proper installation.

3) Disassembly steps

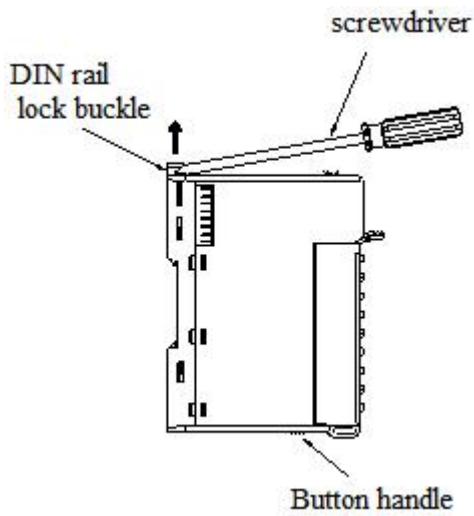

1. Use a screwdriver or similar tool to pry up the guide rail lock, as shown in the left image:

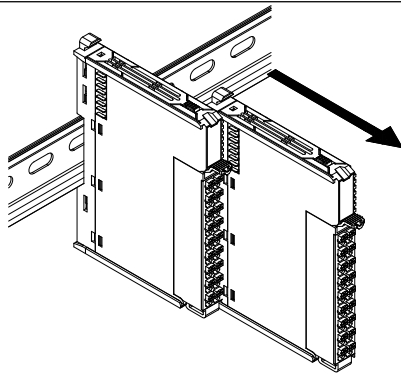

2. Pull the module straight forward from the buckle position (the raised part), then press down the top of the buckle as shown in the left image.

7.4.5.4 Installation Environment

This product supports four installation orientations: horizontal, vertical, top-mounted on electrical cabinets, and bottom-mounted. Horizontal installation is recommended. The cooling system utilizes natural convection. To ensure proper ventilation and heat dissipation while providing sufficient wiring space, a minimum clearance must be maintained around the product, as shown in the figure below.

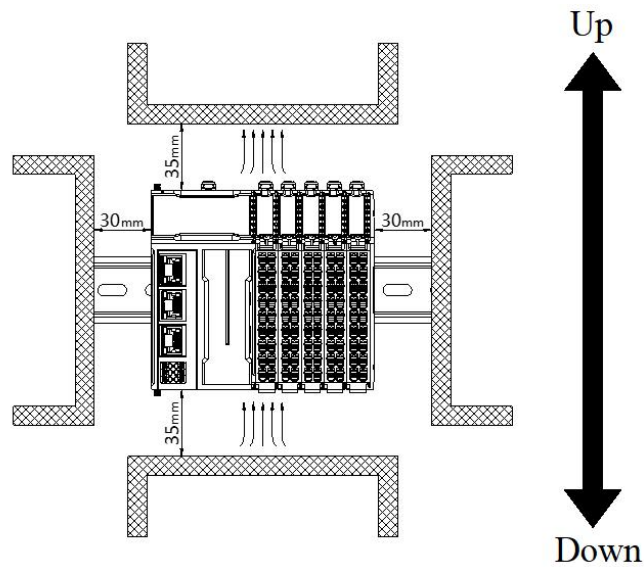

If the product is surrounded by high-temperature heat source equipment (heaters, transformers, large resistors, etc.), maintain a minimum gap of 100mm between the product and such equipment.

7.4.5.5 Equipment Wiring

When wiring the module, its connectors must meet the following requirements:

Suitable wire gauge	
National standard/mm ²	American-Standard /AWG
0.3	22
0.5	20
0.75	18
1.0	18
1.5	16

If using other wire-type terminal lugs, press them onto the stranded wire as shown in the figure below for shape and size requirements.

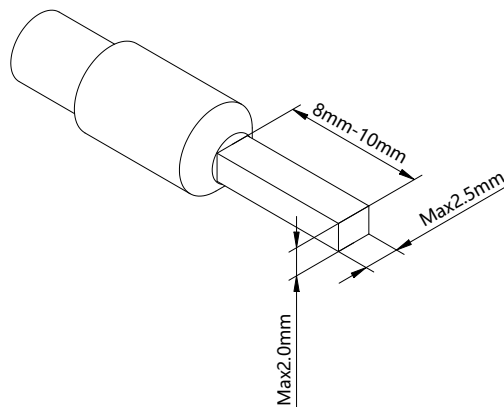

7.4.6 Parameters and Mapping Addresses

name	type	Explanation
XF_E8AD-A	Stuct	8-channel input module
CH0	DINT	Input value for channel 0
CH1	DINT	Input value for channel 1
CH2	DINT	Input value for channel 2
CH3	DINT	Input value for channel 3
CH4	DINT	Input value for channel 4
CH5	DINT	Input value for channel 5
CH6	DINT	Input value for channel 6
CH7	DINT	Input value for channel 7
ErrCode_module	WORD	Module-level error code
ErrCode_CH	DWORD	Channel level error code

■ Error code parameter

Module-level error code (ErrCode_module)		
Bit position	meaning	Error level
0	The 24V input power of the module is abnormal.	Critical
2	An internal module error occurred and the user layer cannot fix it	Critical
3	Version mismatch	Critical
4	ADC/DAC read/write failure	Critical

Channel level error code (ErrCode_CH)		
Bit position	meaning	Error level
0	channel 0 overflow	Medium
1	channel 0 overflow	Medium
2	Channel 0 disconnected	Critical
3	obligate	-
4	channel 1 overflow	Medium
5	channel 1 lower limit overflow	Medium
6	Channel 1 disconnected	Critical
7	obligate	-
8	channel 2 overflow	Medium
9	channel 2 lower limit overflow	Medium

Channel level error code (ErrCode_CH)		
Bit position	meaning	Error level
10	Channel 2 is disconnected	Critical
11	obligate	-
12	channel 3 overflow	Medium
13	channel 3 lower limit overflow	Medium
14	Channel 3 is disconnected	Critical
15	obligate	
16	channel 4 overflow	Medium
17	channel 4 lower limit overflow	Medium
18	Channel 4 is disconnected.	Critical
19	obligate	
...
28	channel 7 overflow	Medium
29	channel 7 lower limit overflow	Medium
30	Channel 7 is disconnected.	Critical

■ configuration parameter

parameter	type	channel	meaning	remarks
Power_Detection	Enumeration of BYTE	-	Power supply detection	0: Close 1: Open
CH0_enable_disable		channel 0	Enable/Disable channel	0: Close 1: Open
CH0_broken_line_detection_enable_disable	Enumeration of BYTE		Enable/Disable line break detection	0: Close 1: Open
CH0_range selection	BYTE		range selection	0: 0~20mA 1: 4~20mA 2: -20~20mA
CH0_filtering_mode			filtering mode	0: First-order filter 1: Time average 2: Average frequency 3: moving average
CH0_FilterPar	INT		filter parameter	Time average (2-100ms) default value 2 Average count (4-500) Default value 4 Moving average (2-500) default value 2 The first-order delay filter (0-254) defaults to 0 (no filtering).
CH0_Calibrate_enable_disable	Enumeration of BYIE		Enable/Disable calibration	0: Close 1: Open

parameter	type	channel	meaning	remarks
CH0_Calibration1_Analog	INT	channel 1	Calibrate 1 analog signal	0~20mA: Analog range: 0~20000μA
CH0_Calibration1_Numerical	DINT		Calibrate 1 digital quantity	Digital range: 0 to 64000 4~20mA:
CH0_Calibration2_Analog	INT		Calibrate the 2 analog signals.	Analog range: 4000~20000uA Digital range: 12800 to 64000
CH0_Calibration2_Numerical	DINT		Calibrate 2 digital quantities	-20~20mA: Analog range: -20000 to 20000 μA Digital range: -32000 to 32000
CH0_unit_display_conversion_enabled_disable	Enumeration of BYTE		Enable/Disable unit display conversion	0: Close 1: Open
CH0_UpperLimit	DINT		Unit display conversion upper limit	Range: -100000000 to 100000000, and the converted unit must be greater than 0.
CH0_LowerLimit			Lower limit of unit conversion	
CH0_Upper_and_lower_limit_overflow_set_enabled_disable	Enumeration of BYTE		Enable/Disable upper/lower bound overflow	0: Close 1: Open
CH0_UpperAnalog	INT		overflow analog signal	0~20mA: Analog range: 0~20000μA
CH0_UpperNumerical	DINT		digital output of upper limit overflow	Digital range: 0 to 64000 4~20mA:
CH0_LowerAnalog	INT		lower limit overflow analog quantity	Analog range: 4000~20000uA Digital range: 12800 to 64000 -20~20mA:
CH0_LowerNumerical	DINT		Lower limit overflow output digital quantity	Analog range: -20000 to 20000μA Digital range: -32000 to 32000
CH1_enable_disable	Enumeration of BYTE		Enable/Disable channel	0: Close 1: Open
CH1_broken_line_detection_enable_disable	Enumeration of BYTE		Enable/Disable line break detection	0: Close 1: Open
CH1_range selection	BYTE	range selection	0: 0~20mA 1: 4~20mA 2: -20~20mA	
CH1_filtering_mode		filtering mode	0: First-order filter 1: Time average 2: Average frequency 3: moving average	
CH1_FilterPar	INT	filter parameter	Time average (2-100ms) default value 2 Average count (4-500) Default value 4	

parameter	type	channel	meaning	remarks
				Moving average (2-500) default value 2 The first-order delay filter (0-254) defaults to 0 (no filtering).
CH1_Calibrate_enable_disable	Enumeration of BYTE		Enable/Disable calibration	0: Close 1: Open
CH1_Calibration1_Analog	INT		Calibrate 1 analog signal	0~20mA: Analog range: 0~20000μA
CH1_Calibration1_Numerical	DINT		Calibrate 1 digital quantity	Digital range: 0 to 64000 4~20mA:
CH1_Calibration2_Analog	INT		Calibrate the 2 analog signals.	Analog range: 4000~20000uA Digital range: 12800 to 64000
CH1_Calibration2_Numerical	DINT		Calibrate 2 digital quantities	-20~20mA: Analog range: -20000 to 20000 μA Digital range: -32000 to 32000
CH1_unit_display_conversion_enabled_disable	Enumeration of BYTE		Enable/Disable unit display conversion	0: Close 1: Open
CH1_UpperLimit	DINT		Unit display conversion upper limit	Range: -100000000 to 100000000, and the converted unit must be greater than 0.
CH1_LowerLimit			Lower limit of unit conversion	
CH1_Upper_and_lower_limit_overflow_set_enabled_disable	Enumeration of BYTE		Enable/Disable upper/lower bound overflow	0: Close 1: Open
CH1_UpperAnalog	INT		overflow analog signal	0~20mA: Analog range: 0~20000μA
CH1_UpperNumerical	DINT		digital output of upper limit overflow	Digital range: 0 to 64000 4~20mA:
CH1_LowerAnalog	INT		lower limit overflow analog quantity	Analog range: 4000~20000uA Digital range: 12800 to 64000 -20~20mA:
CH1_LowerNumerical	DINT		Lower limit overflow output digital quantity	Analog range: -20000 to 20000 μA Digital range: -32000 to 32000
CH2_enable_disable	Enumeration of BYTE		Enable/Disable channel	0: Close 1: Open
CH2_broken_line_detection_enable_disable	Enumeration of BYTE	channel 2	Enable/Disable line break detection	0: Close 1: Open
CH2_range selection	BYTE		range selection	0: 0~20mA

parameter	type	channel	meaning	remarks
				1: 4~20mA 2: -20~20mA
CH2_filtering_mode			filtering mode	0: First-order filter 1: Time average 2: Average frequency 3: moving average
CH2_FilterPar	INT		filter parameter	Time average (2-100ms) default value 2 Average count (4-500) Default value 4 Moving average (2-500) default value 2 The first-order delay filter (0-254) defaults to 0 (no filtering).
CH2_Calibrate_enable_disable	Enumeration of BYTE		Enable/Disable calibration	0: Close 1: Open
CH2_Calibration1_Analog	INT		Calibrate 1 analog signal	0~20mA: Analog range: 0~20000μA
CH2_Calibration1_Numerical	DINT		Calibrate 1 digital quantity	Digital range: 0 to 64000 4~20mA:
CH2_Calibration2_Analog	INT		Calibrate the 2 analog signals.	Analog range: 4000~20000uA Digital range: 12800 to 64000
CH2_Calibration2_Numerical	DINT		Calibrate 2 digital quantities	-20~20mA: Analog range: -20000 to 20000 μA Digital range: -32000 to 32000
CH2_unit_display_conversion_enabled_disable	Enumeration of BYTE		Enable/Disable unit display conversion	0: Close 1: Open
CH2_UpperLimit	DINT		Unit display conversion upper limit	Range: -100000000 to 100000000, and the converted unit must be greater than 0.
CH2_LowerLimit		Lower limit of unit conversion		
CH2_Upper_and_lower_limit_overflow_set_enabled_disable	Enumeration of BYTE		Enable/Disable upper/lower bound overflow	0: Close 1: Open
CH2_UpperAnalog	INT		overflow analog signal	0~20mA: Analog range: 0~20000μA
CH2_UpperNumerical	DINT		digital output of upper limit	Digital range: 0 to 64000 4~20mA:
CH2_LowerAnalog	INT		overflow lower limit	Analog range: 4000~20000uA Digital range: 12800 to 64000
			overflow	-20~20mA:

parameter	type	channel	meaning	remarks
CH2_LowerNumerical	DINT		analog quantity	Analog range: -20000 to 20000
			Lower limit overflow output digital quantity	μA Digital range: -32000 to 32000
.....	channel..
.....	channel
CH3_enable_disable	Enumeration of BYTE	channel7	Enable/Disable channel	0: Close 1: Open
CH3_broken_line_detection_enable_disable	Enumeration of BYTE		Enable/Disable line break detection	0: Close 1: Open
CH3_range selection	BYTE		range selection	0: 0~20mA 1: 4~20mA 2: -20~20mA
CH3_filtering_mode			filtering mode	0: First-order filter 1: Time average 2: Average frequency 3: moving average
CH3_FilterPar	INT		filter parameter	Time average (2-100ms) default value 2 Average count (4-500) Default value 4 Moving average (2-500) default value 2 The first-order delay filter (0-254) defaults to 0 (no filtering).
CH3_Calibrate_enable_disable	Enumeration of BYTE		Enable/Disable calibration	0: Close 1: Open
CH3_Calibration1_Analog	INT		Calibrate 1 analog signal	0~20mA: Analog range: 0~20000μA
CH3_Calibration1_Numerical	DINT		Calibrate 1 digital quantity	Digital range: 0 to 64000 4~20mA:
CH3_Calibration2_Analog	INT		Calibrate the 2 analog signals.	Analog range: 4000~20000uA Digital range: 12800 to 64000
CH3_Calibration2_Numerical	DINT		Calibrate 2 digital quantities	-20~20mA: Analog range: -20000 to 20000 μA Digital range: -32000 to 32000
CH3_unit_display_conversion_enabled_disable	Enumeration of BYTE	Enable/Disable unit display conversion	0: Close 1: Open	
CH3_UpperLimit	DINT	Unit display	Range: -100000000 to	

parameter	type	channel	meaning	remarks
			conversion upper limit	100000000, and the converted unit must be greater than 0.
CH3_LowerLimit			Lower limit of unit conversion	
CH3_Upper_and_lower_limit_overflow_set_enabled_disable	Enumeration of BYTE		Enable/Disable upper/lower bound overflow	0: Close 1: Open
CH3_UpperAnalog	INT		overflow analog signal	0~20mA: Analog range: 0~20000μA
CH3_UpperNumerical	DINT		digital output of upper limit overflow	Digital range: 0 to 64000 4~20mA: Analog range: 4000~20000uA
CH3_LowerAnalog	INT		lower limit overflow analog quantity	Digital range: 12800 to 64000 -20~20mA: Analog range: -20000 to 20000 μA
CH3_LowerNumerical	DINT		Lower limit overflow output digital quantity	Digital range: -32000 to 32000

7.4.7 Functions and Settings

■ Module power detection

- Check if the external 24V power supply for the detection module is normal:
- Normal: The module is functioning properly.
- Error: The module channel is unavailable but can be configured, set up, and scanned.
- Parameters: Enable, disable (disabled by default).

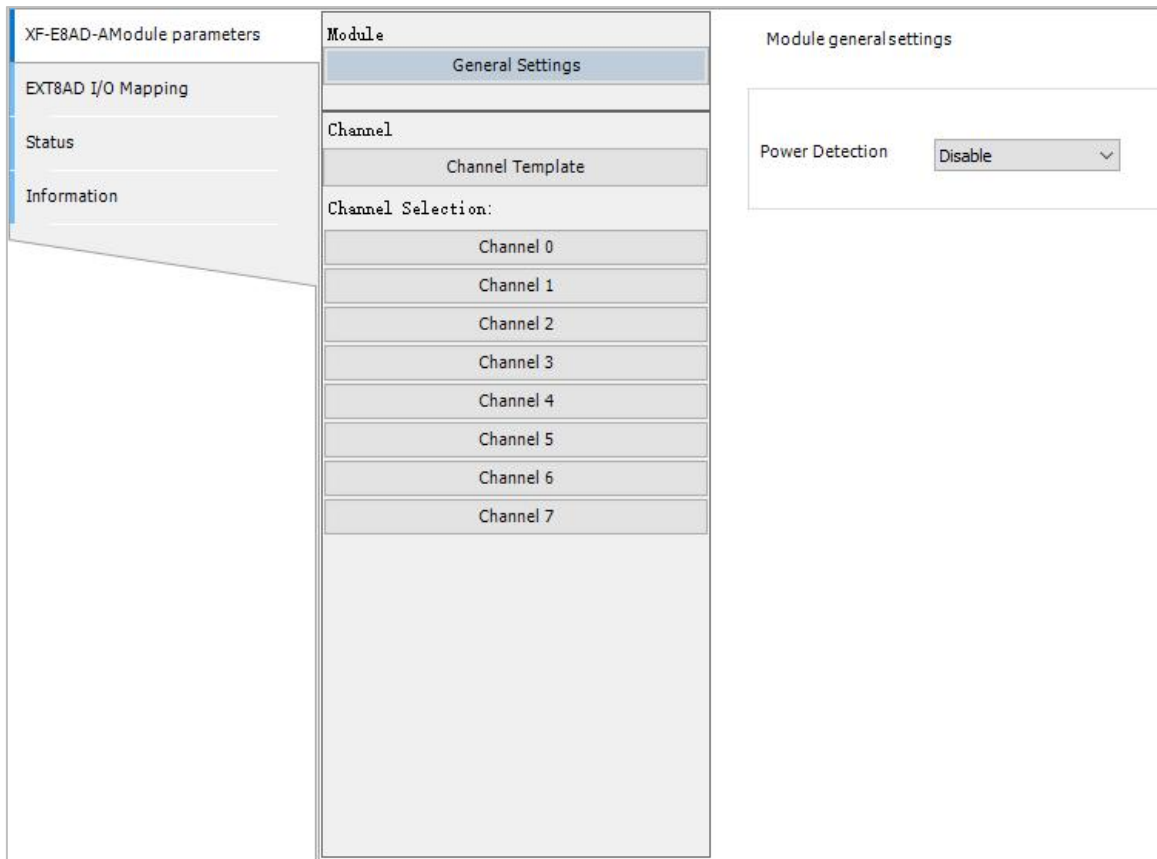

■ Enable/Disable channel

Enable or disable AD sampling channels to save module sampling time.

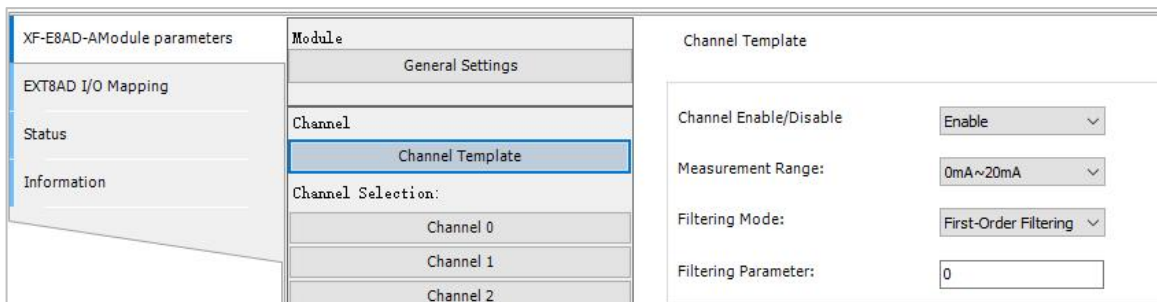

Parameters can be set	Enable or disable (After disabling, you cannot configure subsequent software functions for the corresponding channel)
Default parameters	start using
Matters need attention	Each channel has a conversion time of 60μs. The total time equals the switching speed multiplied by the number of active channels. To reduce the module's total conversion time, you can disable the channel if it is not in use.

■ Sampling type/Range

You can choose different measurement ranges.

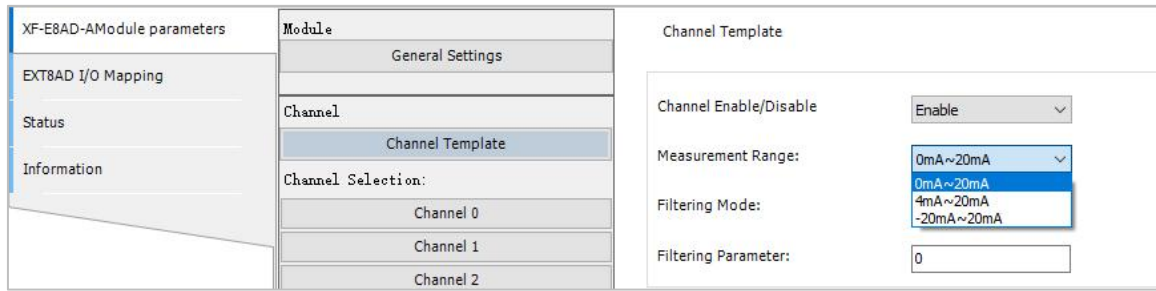

Parameters can be set	The drop-down box method shows configurable parameters
Default parameters	0~20mA
current measurement range	0mA~20mA, 4mA~20mA, -20mA~20mA

■ disconnection detection

- When an abnormality is detected in the AD input channel, disconnect and configure the alarm log. If no current flows through the module or the current is too low (when the XF-E8AD-A measures 4~20 mA or the XF-E8AD-V measures 1~5V), the corresponding alarm log will be triggered, activating both circuit break detection and underflow simultaneously. In this case, the channel value is 0.
- Parameters: Enable, disable (disabled by default).



Only the "Measurement Range" set to "4mA ~ 20mA" and "1V ~ 5V" supports this function.

■ channel filter parameter

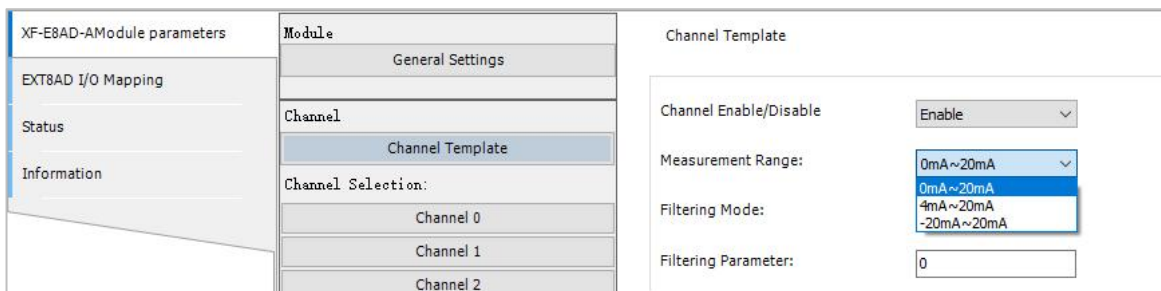

● first order filter

The first-order low-pass filter method combines the current sampling value with the previous filtered output value to produce a filtered result. The filter coefficient, adjustable by the user between 0 and 254, ensures data stability when set lower but may cause delays. A coefficient of 1 delivers optimal filtering performance with maximum stability, while 254 provides minimal filtering. The default setting is 0 (no filtering).

● average filtering

time average	Function actions	Perform A/D conversion based on the set time, then average the total value after removing the maximum and minimum values. The averaged value is stored in the corresponding output buffer. The number of processing cycles within the set time varies according to the number of channels allowed for A/D conversion.
	Set range	2~100ms (default: 2)
number of times average	Function actions	Perform A/D conversion based on the set number of times, and average the total value after removing the maximum and minimum values. The averaged value is stored in the corresponding channel variable. The time for storing the average of the averaged values in the corresponding channel variable varies according to the number of channels allowed for A/D conversion.
	Set range	4 to 500 (default 4)
Moving Average	Function actions	Calculate the average of the specified number of digital output values obtained in each sampling cycle and store it in the corresponding output register/variable. Since moving average processing is performed during each sampling, the latest digital output value can be obtained.
	Set range	2 to 500 (default 2)

- Settable parameter

- ◆ Filter mode (select from dropdown): "First-order filter", "Time average filter", "Frequency average filter", "Moving average filter" (default: First-order filter).
- ◆ Filter parameters (selected via input box): 0~254 (default: 0) for first-order filter mode; 2ms~100ms (default: 2) for time average filter mode; 4~500 (default: 4) for moving average filter mode; 2~500 (default: 2) for moving average filter mode.

- Overflow setting

When the AD channel sampling exceeds the preset upper or lower limit, the system triggers an alarm log and outputs the preset value.

Module General Settings <hr/> Channel Channel Template <hr/> Channel Selection: Channel 0 Channel 1 Channel 2 Channel 3 Channel 4 Channel 5 Channel 6 Channel 7	Channel Template Channel Enable/Disable: <input type="text" value="Enable"/>
	Measurement Range: <input type="text" value="0mA~20mA"/>
	Filtering Mode: <input type="text" value="First-Order Filtering"/>
	Filtering Parameter: <input type="text" value="0"/>
	DisconnectionDetection: <input type="text" value="Disable"/>
	Over/Underflow: <input type="text" value="Enable"/>
	Upper Overflow-Set Value: <input type="text" value="10000"/> <input type="text" value="uA"/>
	Upper Overflow-Output Value: <input type="text" value="64000"/>
	Lower Overflow-Set Value: <input type="text" value="0"/> <input type="text" value="uA"/>
	Lower Overflow-Output Value: <input type="text" value="0"/>

Input current	0~20mA	4~20mA	-20~20mA
Analog range	0~20000uA	4000~20000uA	-20000~20000uA
Digital range	0~64000	12800~64000	-32000~32000

■ Calibration function

Module General Settings <hr/> Channel Channel Template <hr/> Channel Selection: Channel 0 Channel 1 Channel 2 Channel 3 Channel 4 Channel 5 Channel 6 Channel 7	Filtering Parameter: <input type="text" value="0"/>
	DisconnectionDetection: <input type="text" value="Disable"/>
	Over/Underflow: <input type="text" value="Enable"/>
	Upper Overflow-Set Value: <input type="text" value="10000"/> <input type="text" value="uA"/>
	Upper Overflow-Output Value: <input type="text" value="64000"/>
	Lower Overflow-Set Value: <input type="text" value="0"/> <input type="text" value="uA"/>
	Lower Overflow-Output Value: <input type="text" value="0"/>
	Calibration: <input type="text" value="Enable"/>
	AD Calibra2 - Digital: <input type="text" value="64000"/>
	AD Calibra1 - Digital: <input type="text" value="0"/>

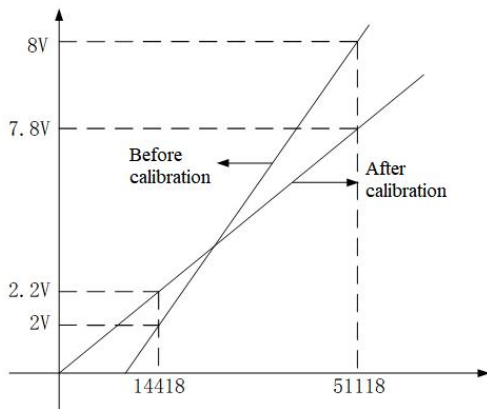

Since the digital values from AD acquisition and conversion may drift from the received analog signals after the product has been in use for some time, customers can calibrate by setting the AD calibration function. The calibration results will be immediately reflected in the proportional scaling value (digital calculation value), allowing them to easily complete the system calibration during startup.

- Parameters: Enable, Disable (default: Disable)
- When the measurement or output range of the module is selected, the analog and digital outputs of calibration 1 and 2 will have different ranges.

Input range	0~20mA	4~20mA	-20~20mA
Calibration for analog signal ranges 1 and 2	0~20000uA	4000~20000uA	-20000~20000uA
Calibrate the digital range of 1 and 2	0~64000	12800~64000	-32000~32000

■ Unit display conversion

Module

General Settings

Channel

Channel Template

Channel Selection:

- Channel 0
- Channel 1
- Channel 2
- Channel 3
- Channel 4
- Channel 5
- Channel 6
- Channel 7

Over/Underflow Enable ▾

Upper Overflow-Set Value: uA

Upper Overflow-Output Value:

Lower Overflow-Set Value: uA

Lower Overflow-Output Value:

Calibration Enable ▾

AD Calibra2 - Digital

AD Calibra1 - Digital

Unit Display Conversion Enable ▾

Unit Display Upper Limit:

Unit Display Lower Limit:

This function can display the input analog data directly as the actual input unit required by the customer. The analog input of the analog expansion module AD is mainly used by some instruments or sensors to input the corresponding analog quantity.

7.5 Analog Input current unit XF-E8AD-V

7.5.1 Product Overview

The XF-E8AD-V series analog voltage input expansion module features 8-channel analog voltage input, compatible with XF/XSF series CPU units and XF series communication coupler units.

- 8-channel analog voltage input;
- channel switching speed 125us/channel;
- Maximum error of 0.2%;
- 12mm width design.

■ Module Version

Hardware version	Firmware version	function
H2.0	V2.0	The basic functions are now officially operational for the first time.

7.5.2 Module View

1) Explanation of each section

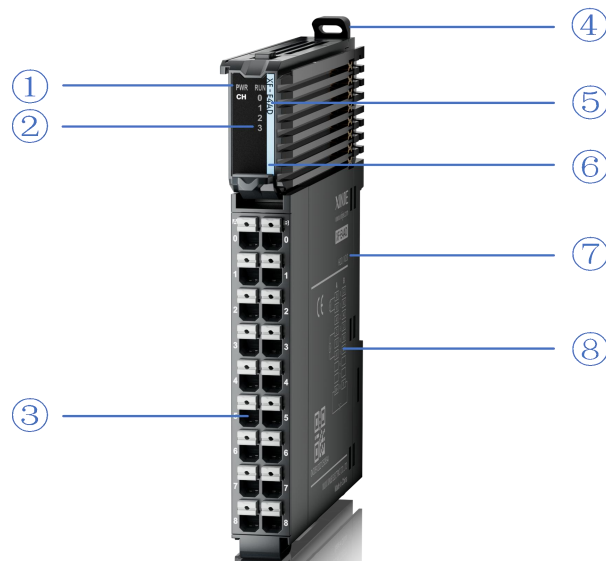

Number	name	Number	name
①	System LED indicator lights	②	Channel LED indicator light
③	disconnectable terminal block	④	fastener
⑤	model indication	⑥	Color code for indicator module type
⑦	Module hardware and Firmware version	⑧	hookup

2) System Indicator Light

System Indicator Light	meaning	
PWR (green)	extinct	Module not powered on (backplane bus)
	Always on	All external power supplies for the module are functioning normally (backplane bus power and external 24V input).
	Flash 1Hz*1	Partial module power supply is abnormal and cannot operate normally (external)
RUN (green)	Always on	The module is running normally
	Flash 1Hz*1	The module encountered a general error in the log
	extinct	The module encountered a critical error in the log
	10Hz*2	Modeling communication
	Dual Flash*3	firmware update



- *1: The duty cycle is 50%, and the frequency is 1Hz, with a square wave.
- *2: The duty cycle is 50%, and the frequency is 10Hz, with a square wave.
- *3: As shown below:

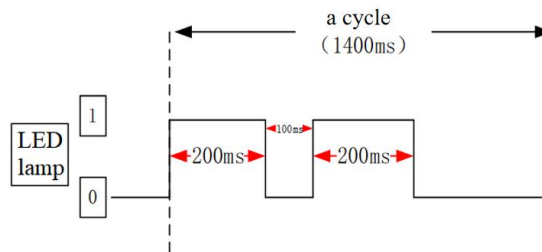

3) Channel indicator light light

model	Channel indicator light		
XF-E8AD-V	CH0~CH7	Always on (green)	The channel is enabled and configured correctly
		10Hz Flash	The channel has an error message
		go out	forbidden channel

4) Color labels

Number	Color	Module type
1	hoar	digital input
2	gray	digital output & digital mixing module
3	wathet	read analogue input
4	mazarine	analog output
5	green	232&485 serial communication
6	rose hermosa	Temperature signal input
7	white	high speed counting
8	purple	pulse output
9	red	repeater power supply

7.5.3 General Specifications

Project		Specifications
Operation temperature	Maximum temperature	55°C
	Minimum temperature	-20°C
Transportation/Storage Temperature	Maximum temperature	70°C
	Minimum temperature	-40°C
Environmental humidity (including operation/storage)	superior limit	95%
	lower limit	10%
Levels of protection		IP20
Anti-vibration		Complies with IEC61131-2 under intermittent vibration (frequency 5-9Hz, constant amplitude 3.5mm peak displacement) and (frequency 9-150Hz, constant acceleration 1.0g peak acceleration) The continuous shock vibration (5-9Hz, half amplitude 1.75mm displacement) and (9-150Hz, constant acceleration 0.5g, constant frame amplitude) Scan 10 times in X, Y, and Z directions
Shock resistance		Complies with IEC61131-2 standard Impact intensity of 15G (peak) was applied for 11ms on three mutually perpendicular axes, with 3 impacts per axis (total 18 impacts).
Operating environment		Non-corrosive gas
Operating altitude		0-2000 meters
Overvoltage class		II: Complies with IEC61131-2
Pollution level		2; Complies with IEC61131-2
Anti-interference EMC		Complies with IEC 61131-2 and IEC 61000-6-4 Type B
Relevant certifications		CE

7.5.4 Technical Specifications

7.5.4.1 Module Performance

Project		Specifications
Input channel		8
Analog input range (specified)	Input voltage range	0V~5V (0~64000) 0V~10V (0~64000) -5V~5V (-32000~32000) -10V~10V (-32000~32000) 1V~5V (12800~64000) Impedance greater than 1M
Maximum input range	Input voltage	DC±15V
Conversion rate		125μs/CH, 250μs/8 channels
Resolution ratio		1/64000 (16Bit)
Module power supply Source	Rated input	DC24V±10%, 150mA
	Protect	reverse protection
Error	Room temperature: 25°C ± 5°C	±0.1%(25±5 °C)
	Full temperature range: -20 to 55°C	±0.2%
Insulate		Channel is not isolated, power is isolated
Module dissipation		0.6W (internal backplane) + 0.65W (external input)
Module weight		80g

7.5.4.2 Module Conversion Diagram

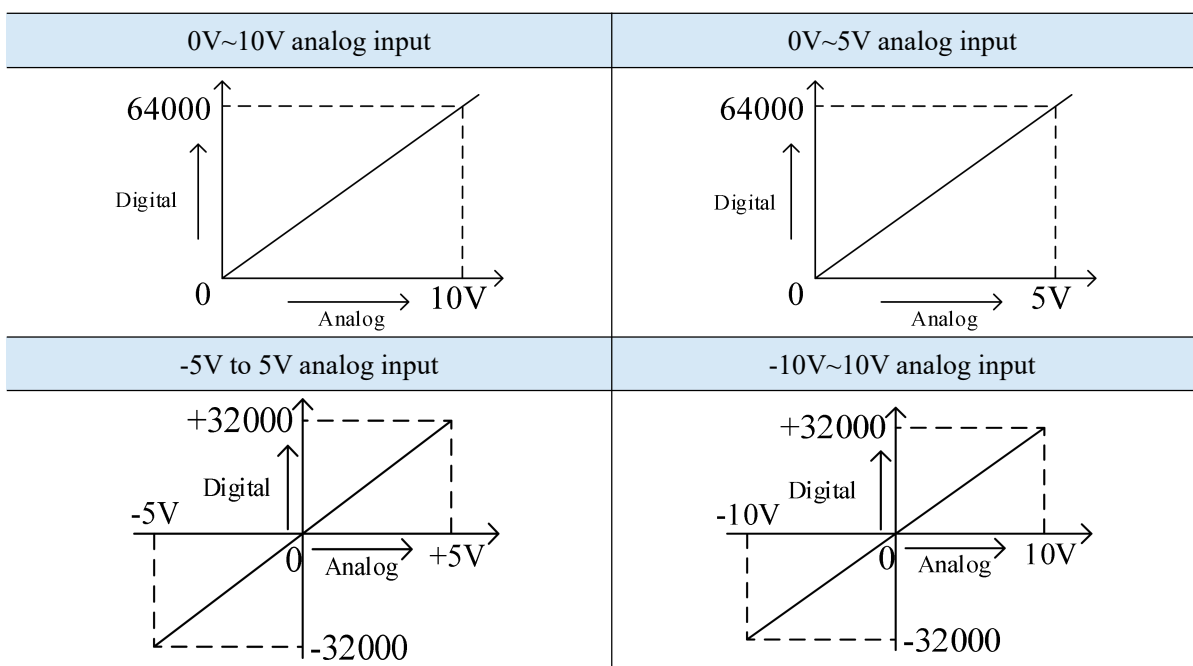

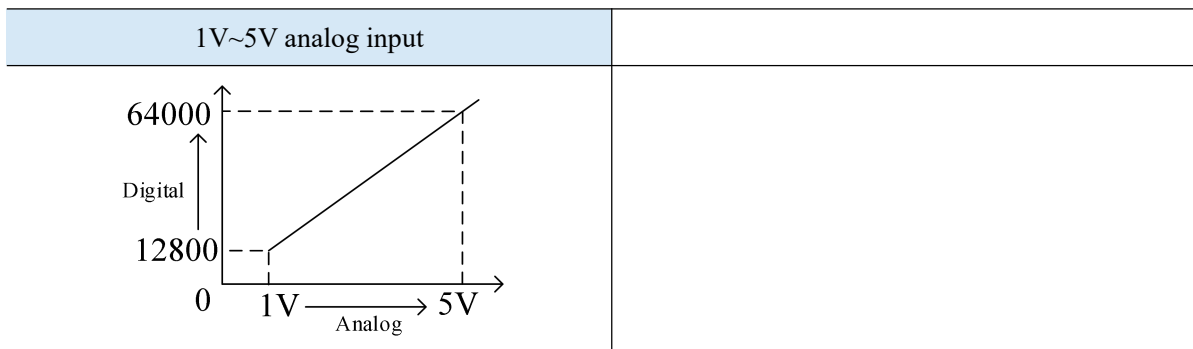

7.5.5 Installation & Wiring

7.5.5.1 Appearance dimensions

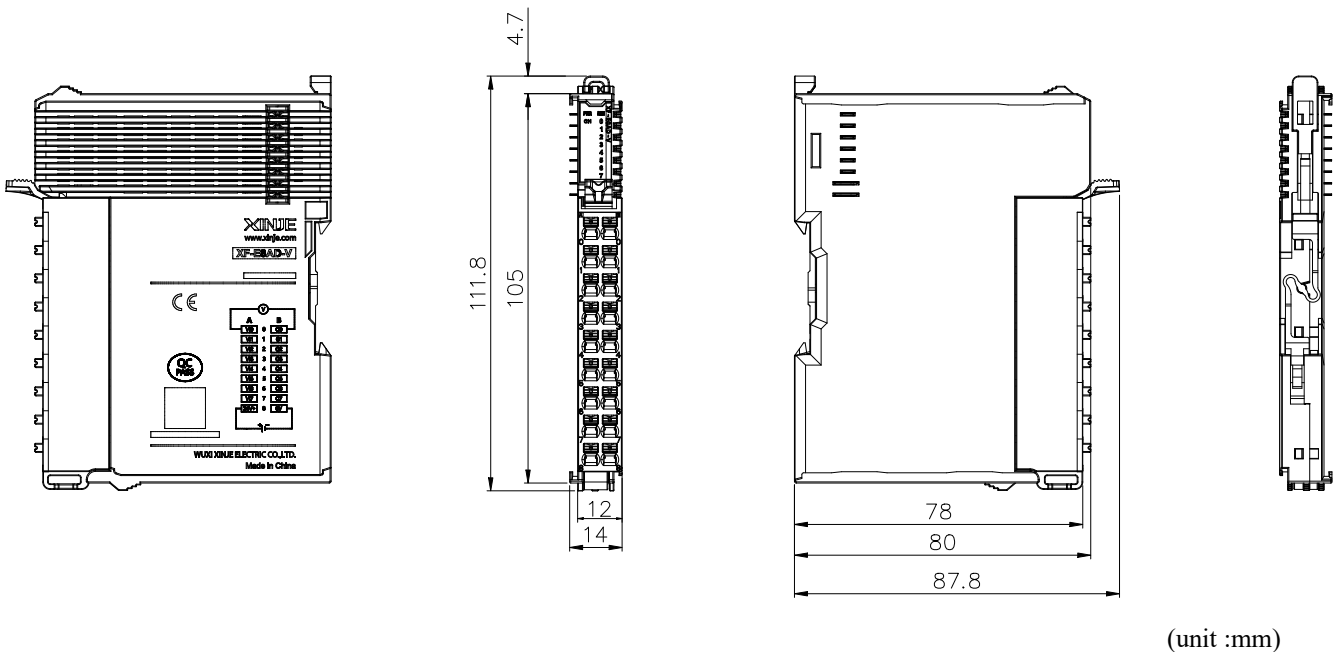

7.5.5.2 Terminal Definitions & Wiring

1) Terminal definition

XF-E8AD-V				
meaning	A terminal	terminal arrangement	B terminal	meaning
CH0-AD analog voltage input terminal	0		0	CH0-Common input terminal
CH1-AD Analog Voltage Input Terminal	1		1	CH1-Common input terminal
CH2-AD analog voltage input terminal	2		2	CH2-Input Common Terminal

XF-E8AD-V				
meaning	A terminal	terminal arrangement	B terminal	meaning
CH3-AD Analog Voltage Input Terminal	3		3	CH3-Input Common Terminal
CH4-AD analog voltage input terminal	4		4	CH4-Input common terminal
CH5-AD Analog Voltage Input Terminal	5		5	CH5-Input common terminal
CH6-AD Analog Voltage Input Terminal	6		6	CH6-Input common terminal
CH7-AD Analog Voltage Input Terminal	7		7	CH7-Input common terminal
The external module receives a 24V positive power supply.	8		8	The external module is powered by a 24V negative power supply.

2) External wiring

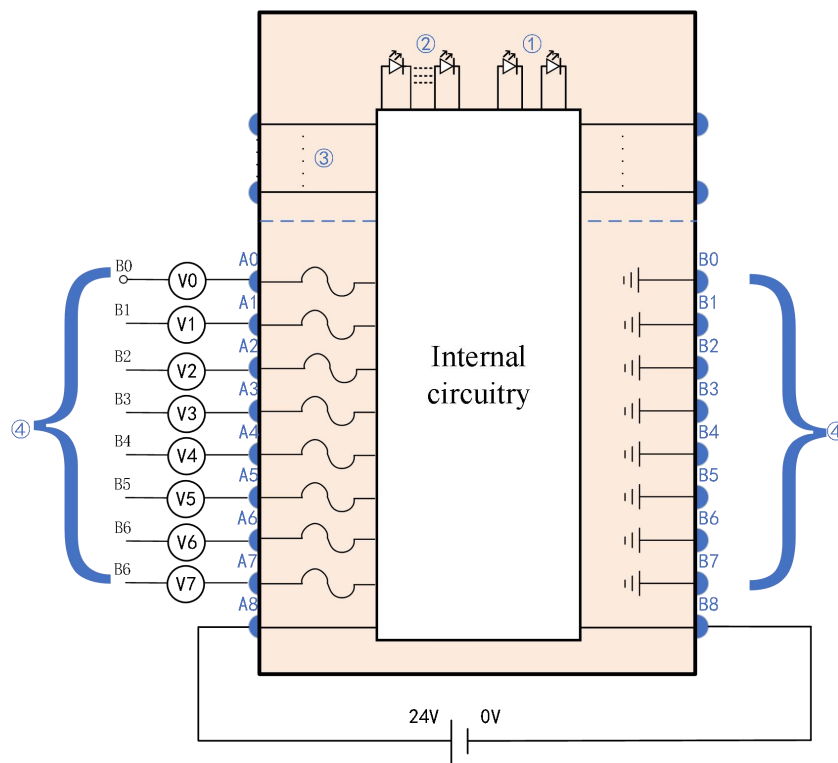

- ① System Indicator Light ② Channel indicator light ③ backplane bus ④ Input channel & wiring light

7.5.5.3 Installation Method

1) Installation requirements

The module is mounted using DIN rails that comply with IEC 60715 standards (35mm wide, 1mm thick). The dimensions are shown in the figure below, with measurements in millimeters.

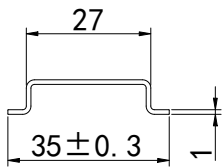

Attention

When the module is installed on a DIN rail not recommended above, the DIN rail latch may fail to lock properly.

2) Installation Steps

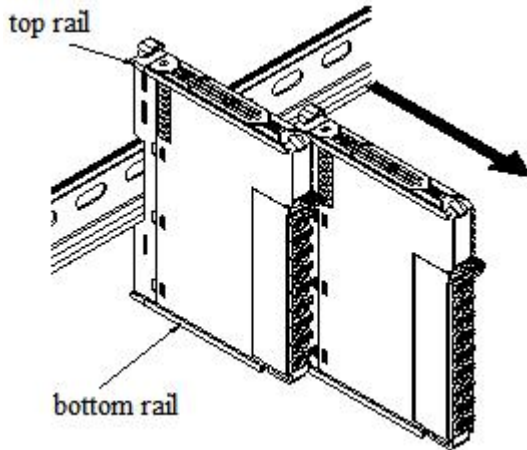

1. The IO modules are assembled by sliding along the top and bottom rails, as shown in the left figure.

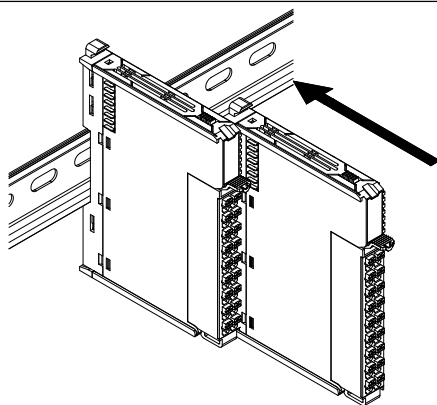

2. The module is mounted on the guide rail. During installation, align the module with the DIN guide rail and press it in the direction indicated by the arrow. A clear click sound will be heard when the module is properly secured, as shown in the left image.

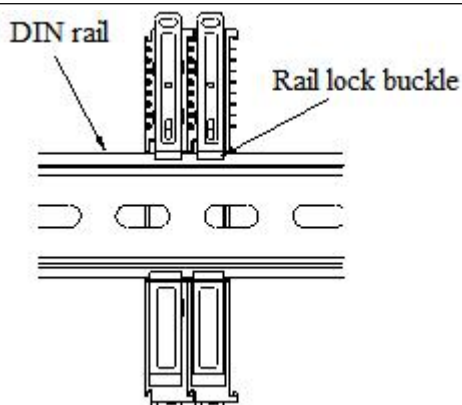

3. After module installation, the latch will automatically lower to lock. If it fails to move down, press the top of the latch downward to ensure proper installation.

3) Disassembly steps

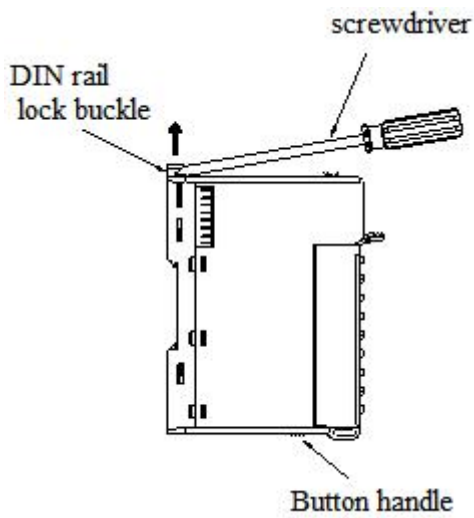

1. Use a screwdriver or similar tool to pry up the guide rail lock, as shown in the left image:

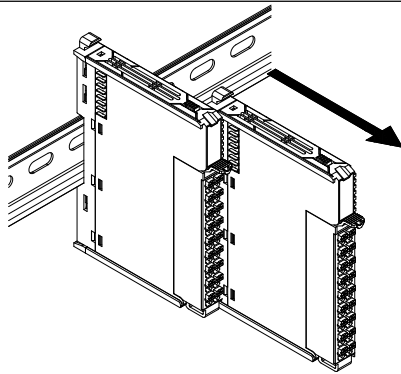

2. Pull the module straight forward from the buckle position (the raised part), then press down the top of the buckle as shown in the left image.

7.5.5.4 Installation Environment

This product supports four installation orientations: horizontal, vertical, top-mounted on electrical cabinets, and bottom-mounted. Horizontal installation is recommended. The cooling system utilizes natural convection. To ensure proper ventilation and heat dissipation while providing sufficient wiring space, a minimum clearance must be maintained around the product, as shown in the figure below.

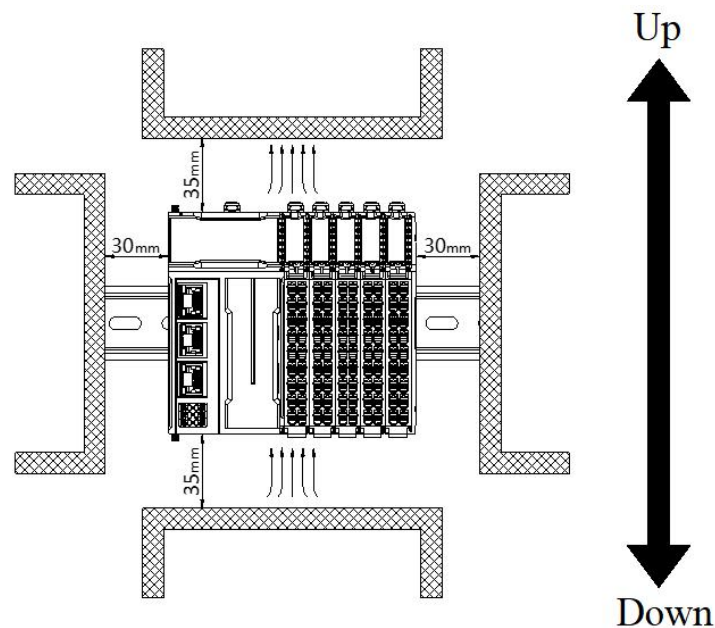



If the product is surrounded by high-temperature heat source equipment (heaters, transformers, large resistors, etc.), maintain a minimum gap of 100mm between the product and such equipment.

7.5.5.5 Equipment Wiring

When wiring the module, its connectors must meet the following requirements:

Suitable wire gauge	
National standard/mm ²	American-Standard /AWG
0.3	22
0.5	20
0.75	18
1.0	18
1.5	16

If using other wire-type terminal lugs, press them onto the stranded wire as shown in the figure below for shape and size requirements.

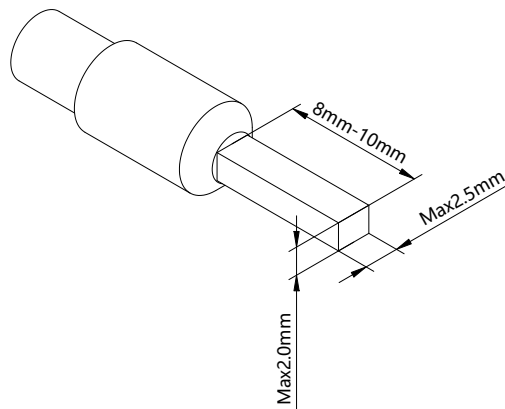

7.5.6 Parameters and Mapping Addresses

name	type	Explanation
XF_E8AD-V	Stuct	8-channel input module
CH0	DINT	Input value for channel 0
CH1	DINT	Input value for channel 1
CH2	DINT	Input value for channel 2
CH3	DINT	Input value for channel 3
CH4	DINT	Input value for channel 4
CH5	DINT	Input value for channel 5
CH6	DINT	Input value for channel 6

name	type	Explanation
XF_E8AD-V	Stuct	8-channel input module
CH7	DINT	Input value for channel 7
ErrCode_module	WORD	Module-level error code
ErrCode_CH	DWORD	Channel level error code

■ Error code parameter

Module-level error code (ErrCode_module)		
Bit position	meaning	Error level
0	The 24V input power of the module is abnormal.	Critical
2	An internal module error occurred and the user layer cannot fix it	Critical
3	Version mismatch	Critical
4	ADC/DAC read/write failure	Critical

Channel level error code (ErrCode_CH)		
Bit position	meaning	Error level
0	channel 0 overflow	Medium
1	channel 0 overflow	Medium
2	Channel 0 disconnected	Critical
3	obligate	-
4	channel 1 overflow	Medium
5	channel 1 lower limit overflow	Medium
6	Channel 1 disconnected	Critical
7	obligate	-
8	channel 2 overflow	Medium
9	channel 2 lower limit overflow	Medium
10	Channel 2 is disconnected	Critical
11	obligate	-
12	channel 3 overflow	Medium
13	channel 3 lower limit overflow	Medium
14	Channel 3 is disconnected	Critical
15	obligate	-
16	channel 4 overflow	Medium
17	channel 4 lower limit overflow	Medium
18	Channel 4 is disconnected.	Critical
19	obligate	-
...
28	channel 7 overflow	Medium
29	channel 7 lower limit overflow	Medium
30	Channel 7 is disconnected.	Critical

■ configuration parameter

parameter	type	channel	meaning	remarks
Power_Detection	Enumeration of BYTE	-	Power supply detection	0: Close 1: Open
CH0_enable_disable			Enable/Disable channel	0: Close 1: Open
CH0_broken_line_detectio n_enable_disable	Enumeration of BYTE		Enable/Disable line break detection	0: Close 1: Open
CH0_range selection	BYTE		range selection	0: 0~10V 1: 0~5V 2: -10~10V 3: -5~5V 4: 1~5V
CH0_filtering_mode			filtering mode	0: First-order filter 1: Time average 2: Average frequency 3: moving average
CH0_FilterPar	INT	channel 0	filter parameter	Time average (2-100ms) default value 2 Average count (4-500) Default value 4 Moving average (2-500) default value 2 The first-order delay filter (0-254) defaults to 0 (no filtering).
CH0_Calibrate_enable_dis able	Enumeration of BYTE		Enable/Disable calibration	0: Close 1: Open
CH0_Calibration1_Analog	INT		Calibrate 1 analog signal	0~10V: Analog range: 0~10000mV
CH0_Calibration1_Numeri cal	DINT		Calibrate 1 digital quantity	Digital range: 0 to 64000 0~5V:
CH0_Calibration2_Analog	INT		Calibrate the 2 analog signals.	Analog range: 0~5000mV Digital range: 0 to 64000
CH0_Calibration2_Numeri cal	DINT		Calibrate 2 digital quantities	-10~10V: Analog range: -10000 to 10000 mV Digital range: -32000 to 32000
				-5~5V: Analog range: -5000 to 5000 mV Digital range: -32000 to 32000
				1~5V: Analog range: 1000mV~5000mV Digital range: 12800 to 64000
CH0_unit_display_convers	Enumeration			Enable/Disable

parameter	type	channel	meaning	remarks
ion_enabled_disable	of BYTE		unit display conversion	
CH0_UpperLimit	DINT		Unit display conversion upper limit	Range: -100000000 to 100000000, and the converted unit must be greater than 0.
CH0_LowerLimit		Lower limit of unit conversion		
CH0_Upper_and_lower_limit_overflow_set_enabled_disable	Enumeration of BYTE		Enable/Disable upper/lower bound overflow	0: Close 1: Open
CH0_UpperAnalog	INT		overflow analog signal	Analog range: in mV, e.g., 0~10V:0~10000mV
CH0_UpperNumerical	DINT		digital output of upper limit overflow	Input voltage 0~10V: Analog range: 0~10000mV
CH0_LowerAnalog	INT		lower limit overflow analog quantity	Digital range: 0 to 64000 0~5V: Analog range: 0~5000mV
CH0_LowerNumerical	DINT		Lower limit overflow output digital quantity	Digital range: 0 to 64000 -10~10V: Analog range: -10000 to 10000 mV Digital range: -32000 to 32000 -5~5V: Analog range: -5000 to 5000 mV Digital range: -32000 to 32000 1~5V: Analog range: 1000mV~5000mV Digital range: 12800 to 64000
CH1_enable_disable	Enumeration of BYTE		Enable/Disable channel	0: Close 1: Open
CH1_broken_line_detection_enable_disable	Enumeration of BYTE		Enable/Disable line break detection	0: Close 1: Open
CH1_range selection	BYTE	channel 1	range selection	0: 0~10V 1: 0~5V 2: -10~10V 3: -5~5V 4: 1~5V
CH1_filtering_mode			filtering mode	0: First-order filter 1: Time average 2: Average frequency 3: moving average
CH1_FilterPar	INT		filter parameter	Time average (2-100ms) default value 2 Average count (4-500) Default value 4 Moving average (2-500) default

parameter	type	channel	meaning	remarks
				value 2 The first-order delay filter (0-254) defaults to 0 (no filtering).
CH1_Calibrate_enable_disable	Enumeration of BYTE		Enable/Disable calibration	0: Close 1: Open
CH1_Calibration1_Analog	INT		Calibrate 1 analog signal	Input voltage 0~10V:
CH1_Calibration1_Numerical	DINT		Calibrate 1 digital quantity	Analog range: 0~10000mV Digital range: 0 to 64000
CH1_Calibration2_Analog	INT		Calibrate the 2 analog signals.	0~5V: Analog range: 0~5000mV Digital range: 0 to 64000
CH1_Calibration2_Numerical	DINT		Calibrate 2 digital quantities	-10~10V: Analog range: -10000 to 10000 mV Digital range: -32000 to 32000 -5~5V: Analog range: -5000 to 5000 mV Digital range: -32000 to 32000 1~5V: The analog signal range is 1000mV to 5000mV. Digital range: 12800 to 64000
CH1_unit_display_conversion_enabled_disable	Enumeration of BYTE		Enable/Disable unit display conversion	0: Close 1: Open
CH1_UpperLimit	DINT		Unit display conversion upper limit	Range: -100000000 to 100000000, and the converted unit must be greater than 0.
CH1_LowerLimit			Lower limit of unit conversion	
CH1_Upper_and_lower_limit_overflow_set_enabled_disable	Enumeration of BYTE		Enable/Disable upper/lower bound overflow	0: Close 1: Open
CH1_UpperAnalog	INT		overflow analog signal	Analog range: in mV, e.g., 0~10V:0~10000mV
CH1_UpperNumerical	DINT		digital output of upper limit overflow	Input voltage 0~10V: Analog range: 0~10000mV
CH1_LowerAnalog	INT		lower limit overflow analog quantity	Digital range: 0 to 64000 0~5V: Analog range: 0~5000mV
CH1_LowerNumerical	DINT		Lower limit overflow output digital quantity	Digital range: 0 to 64000 -10~10V: Analog range: -10000 to 10000

parameter	type	channel	meaning	remarks
				mV Digital range: -32000 to 32000 -5~5V: Analog range: -5000 to 5000 mV Digital range: -32000 to 32000 1~5V: The analog signal range is 1000mV to 5000mV. Digital range: 12800 to 64000
CH2_enable_disable	Enumeration of BYTE	channel 2	Enable/Disable channel	0: Close 1: Open
CH2_broken_line_detection_enable_disable	Enumeration of BYTE		Enable/Disable line break detection	0: Close 1: Open
CH2_range selection	BYTE		range selection	0: 0~10V 1: 0~5V 2: -10~10V 3: -5~5V 4: 1~5V
CH2_filtering_mode			filtering mode	0: First-order filter 1: Time average 2: Average frequency 3: moving average
CH2_FilterPar	INT		filter parameter	Time average (2-100ms) default value 2 Average count (4-500) Default value 4 Moving average (2-500) default value 2 The first-order delay filter (0-254) defaults to 0 (no filtering).
CH2_Calibrate_enable_disable	Enumeration of BYTE		Enable/Disable calibration	0: Close 1: Open
CH2_Calibration1_Analog	INT		Calibrate 1 analog signal	Input voltage 0~10V:
CH2_Calibration1_Numerical	DINT		Calibrate 1 digital quantity	Analog range: 0~10000mV Digital range: 0 to 64000
CH2_Calibration2_Analog	INT		Calibrate the 2 analog signals.	0~5V: Analog range: 0~5000mV
CH2_Calibration2_Numerical	DINT		Calibrate 2 digital quantities	Digital range: 0 to 64000 -10~10V: Analog range: -10000 to 10000 mV Digital range: -32000 to 32000 -5~5V: Analog range: -5000 to 5000 mV Digital range: -32000 to 32000

parameter	type	channel	meaning	remarks
				1~5V: The analog signal range is 1000mV to 5000mV. Digital range: 12800 to 64000
CH2_unit_display_conversion_enabled_disable	Enumeration of BYTE		Enable/Disable unit display conversion	0: Close 1: Open
CH2_UpperLimit	DINT		Unit display conversion upper limit	Range: -100000000 to 100000000, and the converted unit must be greater than 0.
CH2_LowerLimit			Lower limit of unit conversion	
CH2_Upper_and_lower_limit_overflow_set_enabled_disable	Enumeration of BYTE		Enable/Disable upper/lower bound overflow	0: Close 1: Open
CH2_UpperAnalog	INT		upper limit overflow analog quantity	Analog range: in mV, e.g., 0~10V:0~10000mV Input voltage
CH2_UpperNumerical	DINT		digital output of upper limit overflow	0~10V: Analog range: 0~10000mV Digital range: 0 to 64000
CH2_LowerAnalog	INT		lower limit overflow analog quantity	0~5V: Analog range: 0~5000mV Digital range: 0 to 64000
CH2_LowerNumerical	DINT		Lower limit overflow output digital quantity	-10~10V: Analog range: -10000 to 10000 mV Digital range: -32000 to 32000 -5~5V: Analog range: -5000 to 5000 mV Digital range: -32000 to 32000 1~5V: The analog signal range is 1000mV to 5000mV. Digital range: 12800 to 64000
.....	channel
.....	channel
CH3_enable_disable	Enumeration of BYTE		Enable/Disable channel	0: Close 1: Open
CH3_broken_line_detection_enable_disable	Enumeration of BYTE	channel 7	Enable/Disable line break detection	0: Close 1: Open
CH3_range selection	BYTE		range selection	0: 0~10V

parameter	type	channel	meaning	remarks
				1: 0~5V 2: -10~10V 3: -5~5V 4: 1~5V
CH3_filtering_mode			filtering mode	0: First-order filter 1: Time average 2: Average frequency 3: moving average
CH3_FilterPar	INT		filter parameter	Time average (2-100ms) default value 2 Average count (4-500) Default value 4 Moving average (2-500) default value 2 The first-order delay filter (0-254) defaults to 0 (no filtering).
CH3_Calibrate_enable_disable	Enumeration of BYTE		Enable/Disable calibration	0: Close 1: Open
CH3_Calibration1_Analog	INT		Calibrate 1 analog signal	Input voltage 0~10V:
CH3_Calibration1_Numerical	DINT		Calibrate 1 digital quantity	Analog range: 0~10000mV Digital range: 0 to 64000
CH3_Calibration2_Analog	INT		Calibrate the 2 analog signals.	0~5V: Analog range: 0~5000mV
CH3_Calibration2_Numerical	DINT		Calibrate 2 digital quantities	Digital range: 0 to 64000 -10~10V: Analog range: -10000 to 10000 mV Digital range: -32000 to 32000 -5~5V: Analog range: -5000 to 5000 mV Digital range: -32000 to 32000 1~5V: The analog signal range is 1000mV to 5000mV. Digital range: 12800 to 64000
CH3_unit_display_conversion_enabled_disable	Enumeration of BYTE		Enable/Disable unit display conversion	0: Close 1: Open
CH3_UpperLimit	DINT		Unit display conversion upper limit	Range: -100000000 to 100000000, and the converted unit must be greater than 0.
CH3_LowerLimit		Lower limit of unit conversion		
CH3_Upper_and_lower_limit_overflow_set_enabled	Enumeration of BYTE		Enable/Disable upper/lower	0: Close 1: Open

parameter	type	channel	meaning	remarks
_disable			bound overflow	
CH3_UpperAnalog	INT		upper limit overflow analog quantity	Analog range: in mV, e.g., 0~10V:0~10000mV Input voltage
CH3_UpperNumerical	DINT		digital output of upper limit overflow	0~10V: Analog range: 0~10000mV Digital range: 0 to 64000
CH3_LowerAnalog	INT		lower limit overflow analog quantity	0~5V: Analog range: 0~5000mV Digital range: 0 to 64000
CH3_LowerNumerical	DINT		Lower limit overflow output digital quantity	-10~10V: Analog range: -10000 to 10000 mV Digital range: -32000 to 32000 -5~5V: Analog range: -5000 to 5000 mV Digital range: -32000 to 32000 1~5V: The analog signal range is 1000mV to 5000mV. Digital range: 12800 to 64000

7.5.7 Functions and Settings

■ Module power detection

- Check if the external 24V power supply for the detection module is normal:
- Normal: The module is functioning properly.
- Error: The module channel is unavailable but can be configured, set up, and scanned.
- Parameters: Enable, disable (disabled by default).

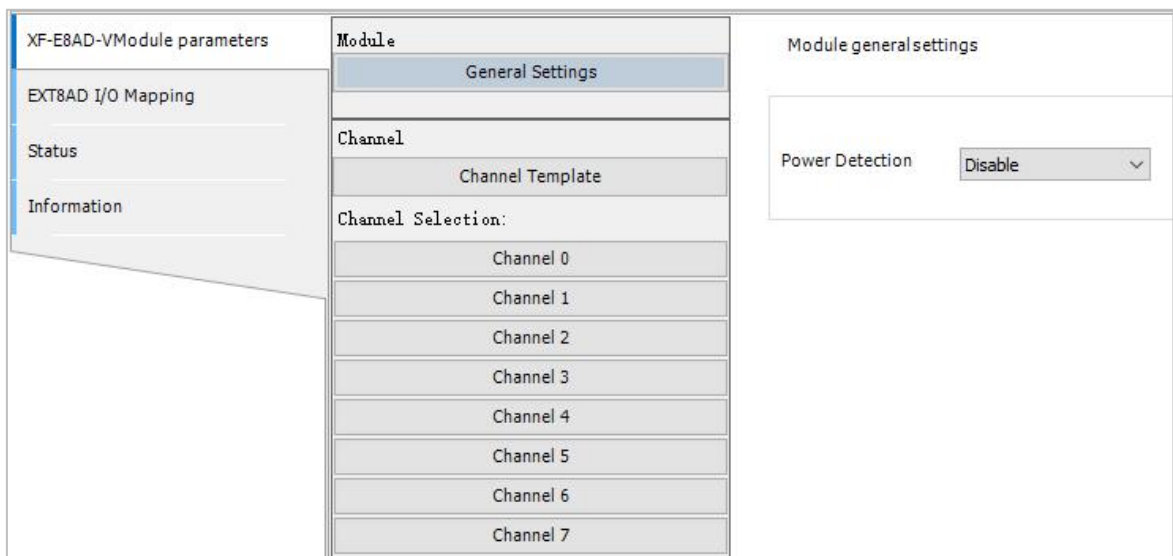

■ Enable/Disable channel

Enable or disable AD sampling channels to save module sampling time.

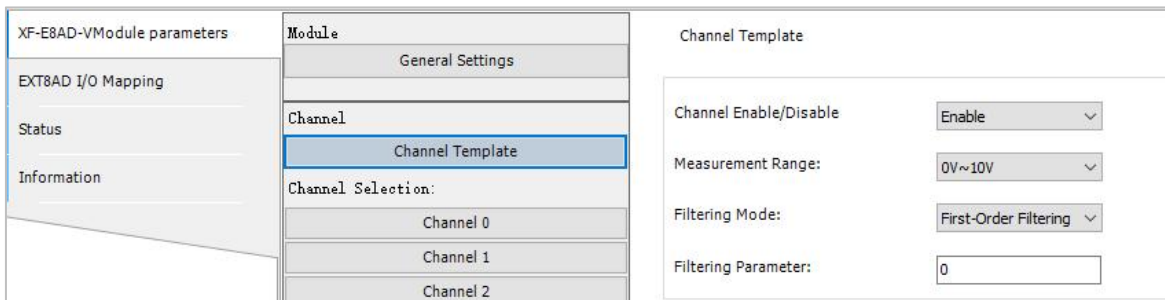

Parameters can be set	Enable or disable (After disabling, you cannot configure subsequent software functions for the corresponding channel)
Default parameters	start using
Matters need attention	Each channel has a conversion time of 60μs. The total time equals the switching speed multiplied by the number of active channels. To reduce the module's total conversion time, you can disable the channel if it is not in use.

■ Sampling type/Range

You can choose different measurement ranges.

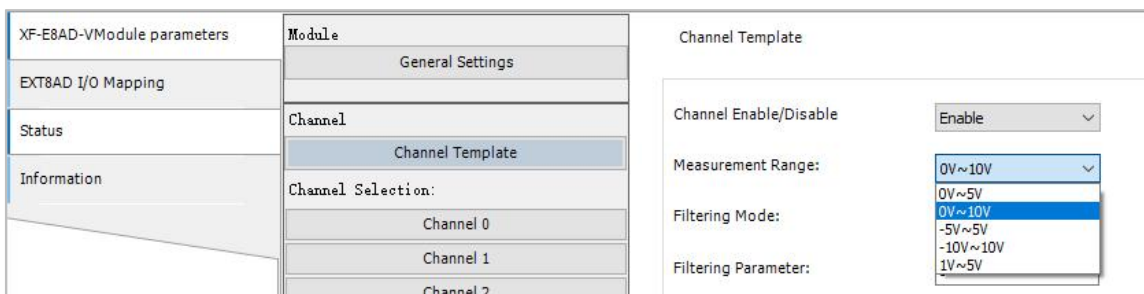

Parameters can be set	The drop-down box method shows configurable parameters
Default parameters	0V~10V
Voltage measurement range	0V~5V,0V~10V,-5V~5V,-10V~10V,1V~5V

■ disconnection detection

- When an abnormality is detected in the AD input channel, disconnect and configure the alarm log. If no current flows through the module or the current is too low (when the XF-E8AD-A measures 4~20 mA or the XF-E8AD-V measures 1~5V), the corresponding alarm log will be triggered, activating both circuit break detection and underflow simultaneously. In this case, the channel value is 0.
- Parameters: Enable, disable (disabled by default).



Only the "Measurement Range" set to "4mA ~ 20mA" and "1V ~ 5V" supports this function.

■ channel filter parameter

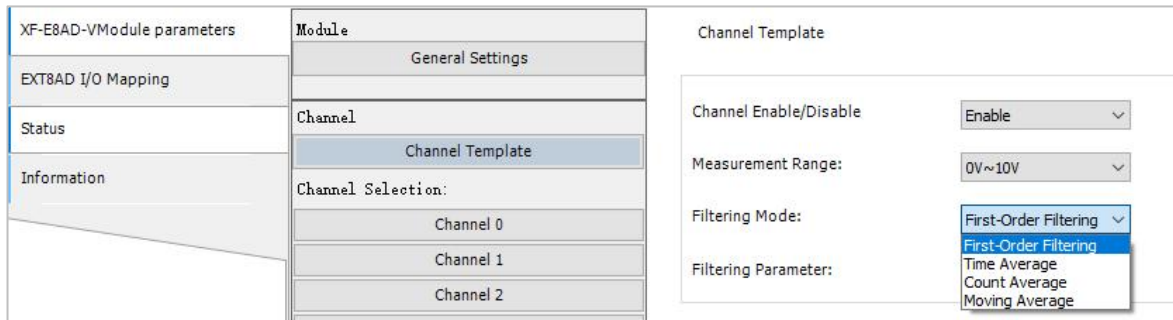

● first order filter

The first-order low-pass filter method combines the current sampling value with the previous filtered output value to produce a filtered result. The filter coefficient, adjustable by the user between 0 and 254, ensures data stability when set lower but may cause delays. A coefficient of 1 delivers optimal filtering performance with maximum stability, while 254 provides minimal filtering. The default setting is 0 (no filtering).

● average filtering

time average	Function actions	Perform A/D conversion based on the set time, then average the total value after removing the maximum and minimum values. The averaged value is stored in the corresponding output buffer. The number of processing cycles within the set time varies according to the number of channels allowed for A/D conversion.
	Set range	2–100ms (default: 2)
number of times average	Function actions	Perform A/D conversion based on the set number of times, and average the total value after removing the maximum and minimum values. The averaged value is stored in the corresponding channel variable. The time for storing the average of the averaged values in the corresponding channel variable varies according to the number of channels allowed for A/D conversion.
	Set range	4 to 500 (default 4)
shift Average per	Function actions	Calculate the average of the specified number of digital output values obtained in each sampling cycle and store it in the corresponding output register/variable. Since moving average processing is performed during each sampling, the latest digital output value can be obtained.
	Set range	2 to 500 (default 2)

● Settable parameter

- ◆ Filter mode (select from dropdown): "First-order filter", "Time average filter", "Frequency average filter", "Moving average filter" (default: First-order filter).
- ◆ Filter parameters (selected via input box): 0~254 (default: 0) for first-order filter mode; 2ms~100ms (default: 2) for time average filter mode; 4~500 (default: 4) for moving average filter mode; 2~500 (default: 2) for moving average filter mode.

■ overflow setting

When the AD channel sampling exceeds the preset upper or lower limit, the system triggers an alarm log and outputs the preset value.

Input voltage	0~5V	0~10V	-5~5V	-10~10V	1~5V
analog range	0~5000mV	0~10000mV	-5000~5000mV	-10000~10000mV	1000~5000mV
digital range	0~64000	0~64000	-32000~32000	-32000~32000	12800~64000

■ Calibration function

Module General Settings <hr/> Channel Channel Template <hr/> Channel Selection: Channel 0 Channel 1 Channel 2 Channel 3 Channel 4 Channel 5 Channel 6 Channel 7	Filtering Parameter: <input type="text" value="0"/>
	DisconnectionDetection: <input type="text" value="Disable"/>
	Over/Underflow: <input type="text" value="Disable"/>
	Upper Overflow-Set Value: <input type="text" value="10000"/> mV
	Upper Overflow-Output Value: <input type="text" value="64000"/>
	Lower Overflow-Set Value: <input type="text" value="0"/> mV
	Lower Overflow-Output Value: <input type="text" value="0"/>
	Calibration: <input type="text" value="Disable"/>
	AD Calibra2 - Digital: <input type="text" value="64000"/> AD Calibra1 - Digital: <input type="text" value="0"/>

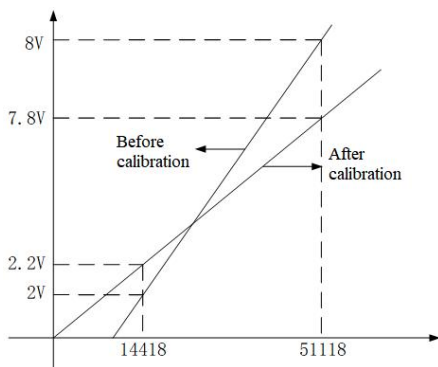

Since the digital values from AD acquisition and conversion may drift from the received analog signals after the product has been in use for some time, customers can calibrate by setting the AD calibration function. The calibration results will be immediately reflected in the proportional scaling value (digital calculation value), allowing them to easily complete the system calibration during startup.

- Parameters: Enable, Disable (default: Disable)
- When the measurement or output range of the module is selected, the analog and digital outputs of calibration 1 and 2 will have different ranges.

Input voltage range	0~5V	0~10V	-5~5V	-10~10V	1~5V
Calibration for analog signal ranges 1 and 2	0~5000mV	0~10000mV	-5000~5000mV	-10000~10000mV	1000~5000mV
Calibrate the digital range of 1 and 2.	0~64000	0~64000	-32000~32000	-32000~32000	12800~64000

■ Unit display conversion

Module	
General Settings	
Channel	
Channel Template	
Channel Selection:	
Channel 0	
Channel 1	
Channel 2	
Channel 3	
Channel 4	
Channel 5	
Channel 6	
Channel 7	

Over/Underflow:

Upper Overflow-Set Value: mV

Upper Overflow-Output Value:

Lower Overflow-Set Value: mV

Lower Overflow-Output Value:

Calibration:

AD Calibra2 - Digital:

AD Calibra1 - Digital:

AD Calibra1 - Analog: mV

AD Calibra2 - Analog: mV

Unit Display Conversion:

Unit Display Upper Limit:

Unit Display Lower Limit:

This function can display the input analog data directly as the actual input unit required by the customer. Since the analog expansion module AD is used by customers, the input basically consists of some instruments or sensors to input the corresponding analog quantities.

7.6 Analog Current Output Unit XF-E8DA-A

7.6.1 Product Overview

The XF-E8DA-A series analog current output expansion module features 8-channel analog current output and is compatible with XF/XSF series CPU units as well as XF series communication coupler units.

- 8-channel analog current output;
- Channel switching speed: 1.5 ms per 8 channels;
- Maximum error of 0.2%;
- Designed with a 12mm width.

■ Module Version

Hardware Version	Firmware version	function
H2	V2.0	The basic functions have been officially put into production for the first time.

7.6.2 Module View

1) Description of each section

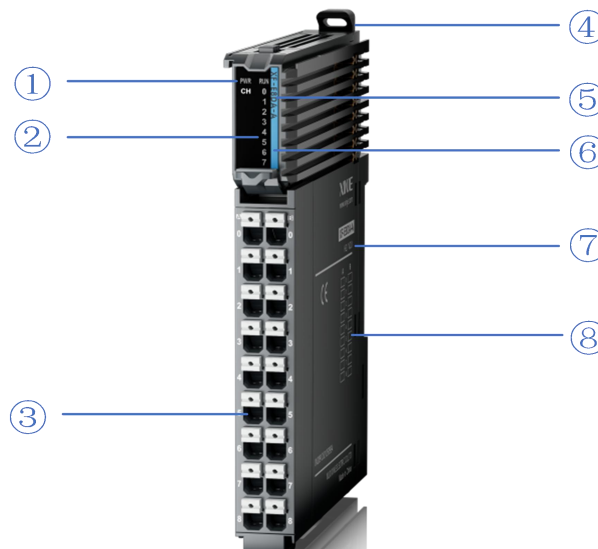

Number	Name	Number	Name
①	System LED indicator light	②	Channel LED indicator light
③	Removable terminal block	④	snap joint
⑤	Model Identification	⑥	Color identifier for the indicator module type
⑦	Module hardware and Firmware version	⑧	Wiring diagram

2) System Indicator Light

System Indicator Light	meaning	
PWR (green)	extinct	Module not powered on (backplane bus)
	Always on	All external power supplies for the module are functioning normally (backplane bus power and external 24V input).
	Flash 1Hz*1	Partial module power supply is abnormal and cannot operate normally (external)
RUN	Always on	The module is running normally

System Indicator Light	meaning	
(green)	Flash 1Hz* ¹	The module encountered a general error in the log
	extinct	The module encountered a critical error in the log
	10Hz* ²	Modeling communication
	Dual Flash* ³	firmware update



- *1: The duty cycle is 50%, and the frequency is 1Hz, with a square wave.
- *2: The duty cycle is 50%, and the frequency is 10Hz, with a square wave.
- *3: As shown below:

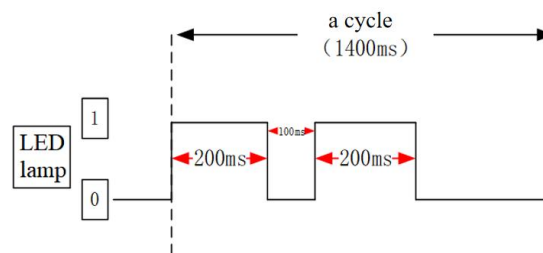

3) Channel indicator light light

model	Channel indicator light		
XF-E8DA-A	CH0~CH7	Always on (green)	The channel is enabled and configured correctly
		10Hz Flash	The channel has an error message
		go out	forbidden channel

4) Color labels

Number	Color		Module type
1		hoar	digital input
2		gray	digital output & digital mixing module
3		wathet	read analogue input
4		mazarine	analog output
5		green	232&485 serial communication
6		rose hermosa	Temperature signal input
7		white	high speed counting
8		purple	pulse output
9		red	repeater power supply

7.6.3 General Specifications

project		specifications
Operation temperature	Maximum temperature	55°C
	Minimum temperature	-20°C
Transportation/Storage Temperature	Maximum temperature	70°C
	Minimum temperature	-40°C
Environmental humidity (including operation/storage)	superior limit	95%
	lower limit	10%
Levels of protection		IP20
Anti-vibration		Complies with IEC61131-2 under intermittent vibration (frequency 5-9Hz, constant amplitude 3.5mm peak displacement) and (frequency 9-150Hz, constant acceleration 1.0g peak acceleration) The continuous shock vibration (5-9Hz, half amplitude 1.75mm displacement) and (9-150Hz, constant acceleration 0.5g, constant frame amplitude) Scan 10 times in X, Y, and Z directions
Shock resistance		Complies with IEC61131-2 standard Impact intensity of 15G (peak) was applied for 11ms on three mutually perpendicular axes, with 3 impacts per axis (total 18 impacts).
Operating environment		Non-corrosive gas
Operating altitude		0-2000 meters
Overvoltage class		II: Complies with IEC61131-2
Pollution level		2; Complies with IEC61131-2
Anti-interference EMC		Complies with IEC 61131-2 and IEC 61000-6-4 Type B
Relevant certifications		CE

7.6.4 Technical Specifications

7.6.4.1 Module Performance

Project		Specifications
Input channel		8
Analog output range (specified)	output range	0mA~20mA (0~64000) 4mA~20mA (12800~64000) The external load resistance is less than 500 Ω.
Maximum output range	current output	-40~40mA

Project		Specifications
Conversion rate		150us/CH, 1.5ms/8CH
Resolution ratio		1/64000 (16Bit)
Module power supply Source	Rated input	DC24V±10%, 150mA
	Protect	reverse protection
Error	Room temperature: 25°C ± 5°C	±0.1%(25±5 °C)
	Full temperature range: -20 to 55°C	±0.2%
Insulate		Channel is not isolated, power is isolated
Module dissipation		0.75W (internal backplane) +1.45W (outside input)
Module weight		88g

7.6.4.2 Module Conversion Diagram

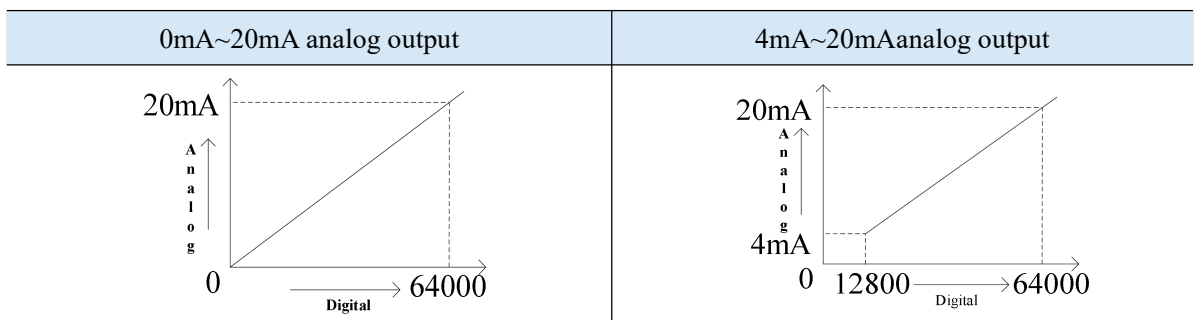

7.6.5 Installation & Wiring

7.6.5.1 Appearance dimensions

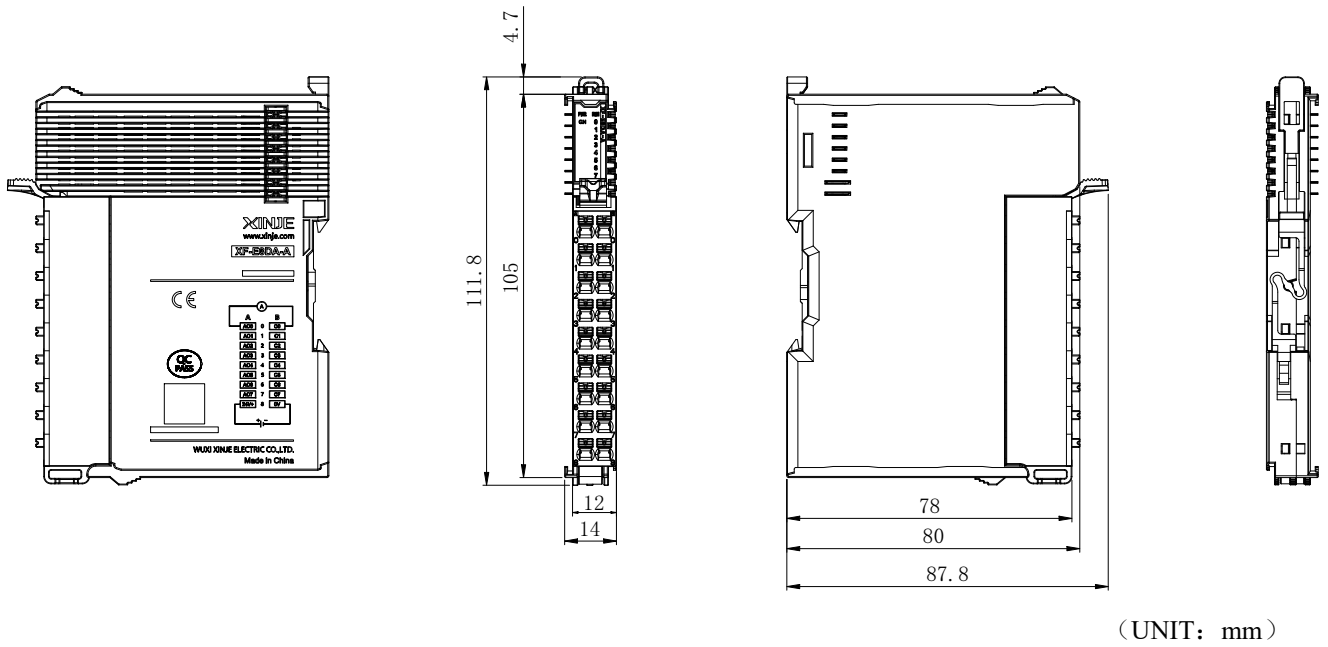

7.6.5.2 Terminal Definitions & Wiring

1) Terminal definition

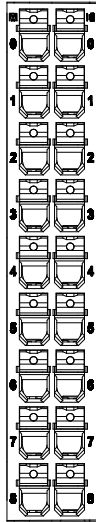
XF-E8DA-A				
Meaning	A terminal	Terminal arrangement	B terminal	Meaning
CH0-AD analog current output terminal	0		0	CH0-Common output terminal
CH1-AD Analog Current output Terminal	1		1	CH1-Common output terminal
CH2-AD analog current output terminal	2		2	CH2-output Common Terminal
CH3-AD analog current output terminal	3		3	CH3-output Common Terminal
CH4-AD analog current output terminal	4		4	CH4-output common terminal
CH5-AD analog current output terminal	5		5	CH5-output common terminal
CH6-AD analog current output terminal	6		6	CH6-output common terminal
CH7-AD Analog Current output Terminal	7		7	CH7-output common terminal
The external module receives a 24V positive power supply.	8		8	The external module is powered by a 24V negative power supply.

2) External wiring

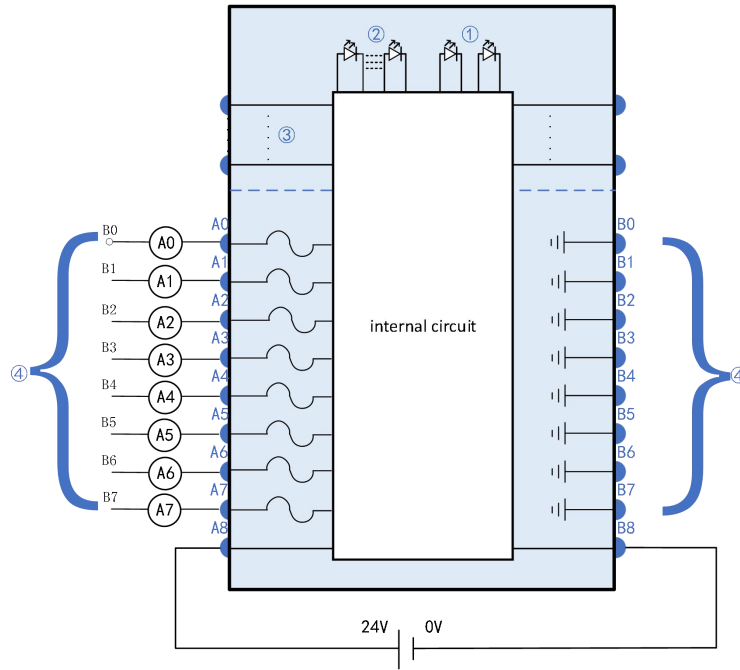

- ① System Indicator Light ② Channel indicator light ③ backplane bus ④ Input channel & wiring light

7.6.5.3 Installation Method

1) Installation requirements

The module is mounted using DIN rails that comply with IEC 60715 standards (35mm wide, 1mm thick). The dimensions are shown in the figure below, with measurements in millimeters.

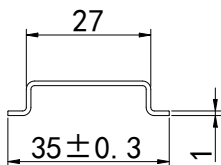

Attention

When the module is installed on a DIN rail not recommended above, the DIN rail latch may fail to lock properly.

2) Installation Steps

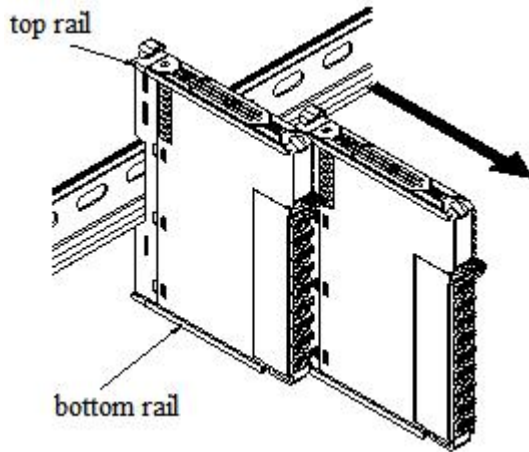

1. The IO modules are assembled by sliding along the top and bottom rails, as shown in the left figure.

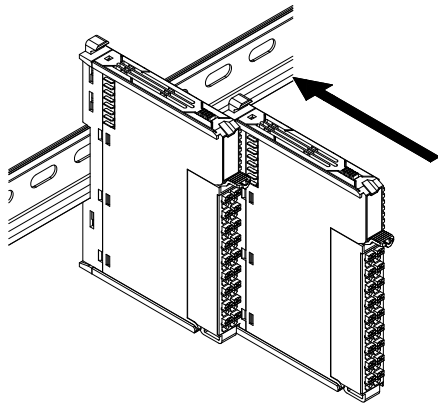

2. The module is mounted on the guide rail. During installation, align the module with the DIN guide rail and press it in the direction indicated by the arrow. A clear click sound will be heard when the module is properly secured, as shown in the left image.

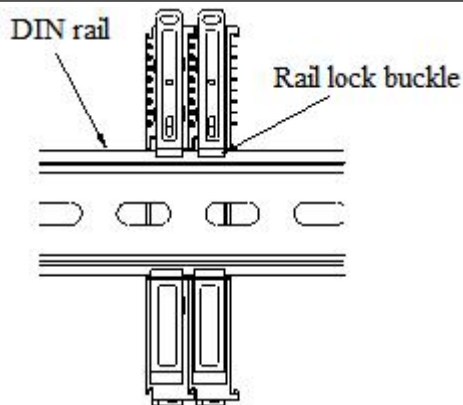

3. After module installation, the latch will automatically lower to lock. If it fails to move down, press the top of the latch downward to ensure proper installation.

3) Disassembly steps

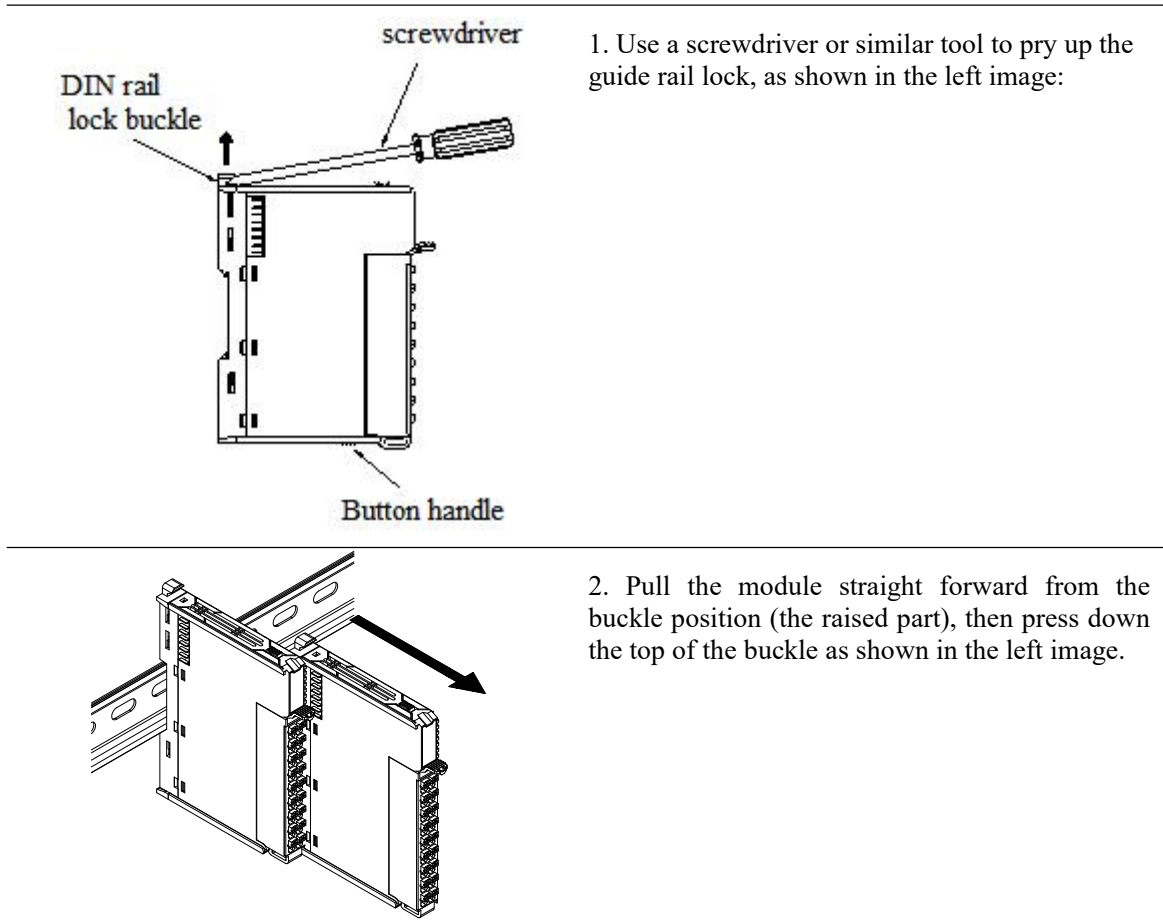

7.4.5.4 Installation Environment

This product supports four installation orientations: horizontal, vertical, top-mounted on electrical cabinets, and bottom-mounted. Horizontal installation is recommended. The cooling system utilizes natural convection. To ensure proper ventilation and heat dissipation while providing sufficient wiring space, a minimum clearance must be maintained around the product, as shown in the figure below.

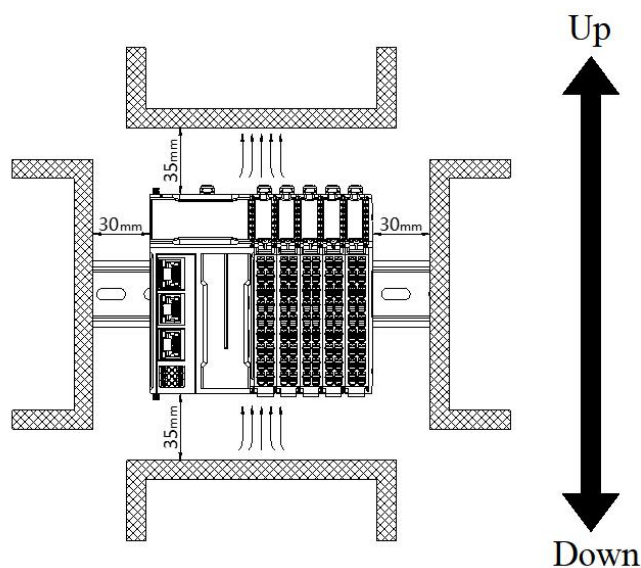



If the product is surrounded by high-temperature heat source equipment (heaters, transformers, large resistors, etc.), maintain a minimum gap of 100mm between the product and such equipment.

7.6.5.5 Equipment Wiring

When wiring the module, its connectors must meet the following requirements:

Suitable wire gauge	
National standard/mm ²	American-Standard /AWG
0.3	22
0.5	20
0.75	18
1.0	18
1.5	16

If using other wire-type terminal lugs, press them onto the stranded wire as shown in the figure below for shape and size requirements.

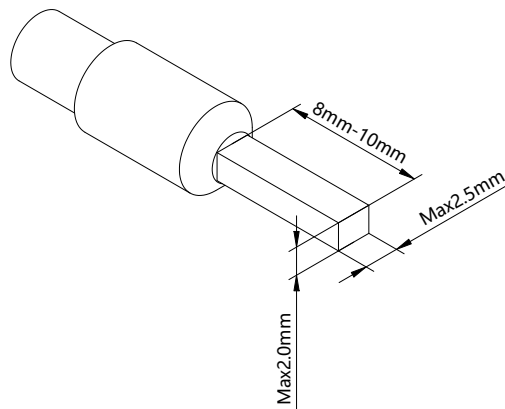

7.6.6 Parameters and Mapping Addresses

Name	Type	Explanation
XF_E8DA-A	Stuct	8-channel Output module
CH0	DINT	Output value for channel 0
CH1	DINT	Output value for channel 1
CH2	DINT	Output value for channel 2
CH3	DINT	Output value for channel 3
CH4	DINT	Output value for channel 4
CH5	DINT	Output value for channel 5
CH6	DINT	Output value for channel 6

Name	Type	Explanation
XF_E8DA-A	Stuct	8-channel Output module
CH7	DINT	Output value for channel 7
ErrCode_module	WORD	Module-level error code
ErrCode_CH	DWORD	Channel level error code

■ Error code parameter

Module-level error code (ErrCode_module)		
Bit position	meaning	Error level
0	The 24V input power of the module is abnormal.	Critical
2	An internal module error occurred and the user layer cannot fix it	Critical
3	Version mismatch	Critical
4	ADC/DAC read/write failure	Critical

7.6.7 Functions and Settings

■ Module power detection

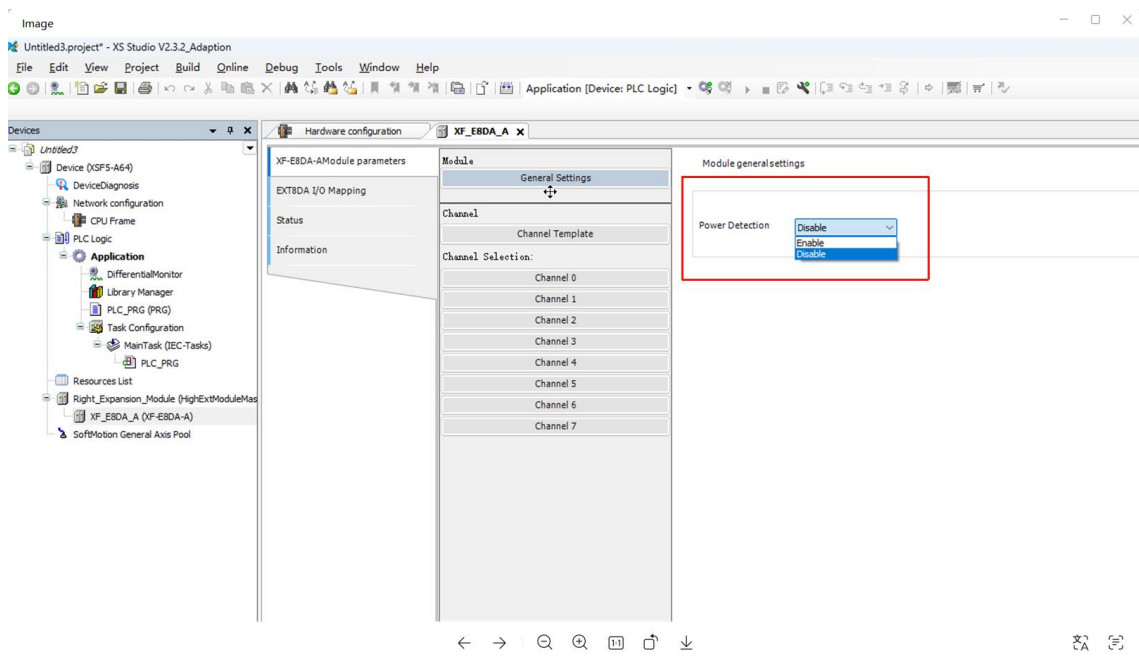

- Check if the external 24V power supply for the detection module is normal:
- Normal: The module is functioning properly.
- Error: The module channel is unavailable but can be configured, set up, and scanned.

Parameters can be set	Enable or disable (After disabling, you cannot configure subsequent software functions for the corresponding channel)
-----------------------	---

Default parameters	start using
--------------------	-------------

■ Enable/Disable channel

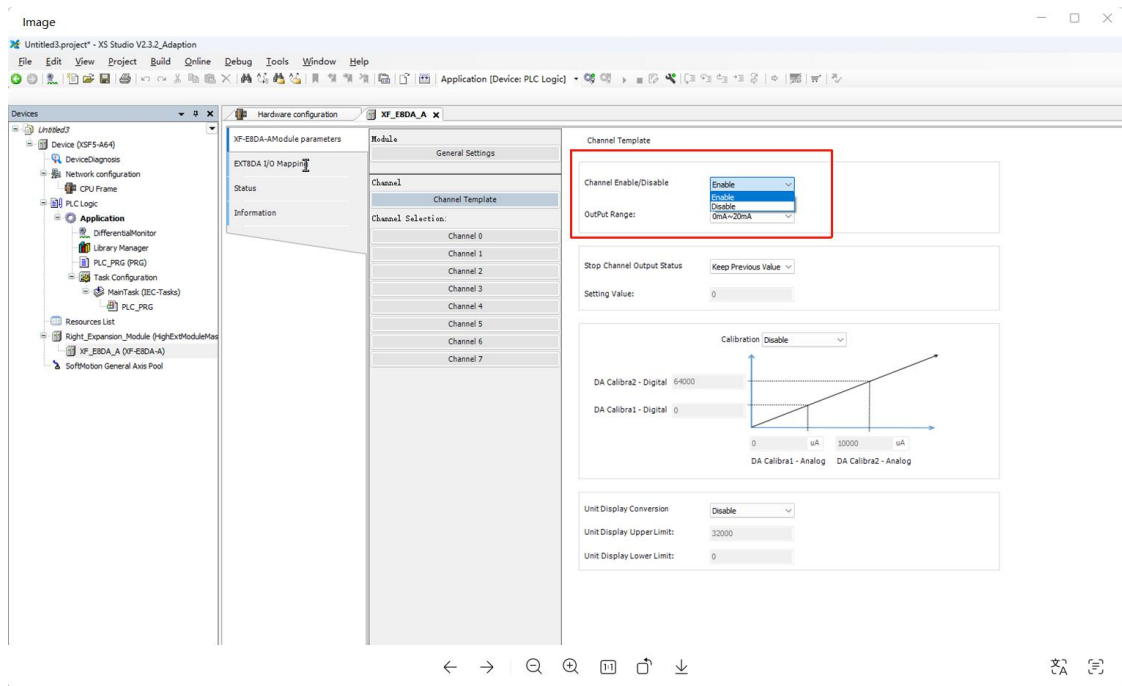

Enable or disable the DA output channel to save module sampling time.

Parameters can be set	The drop-down box method shows configurable parameters
Default parameters	Enable
Matters need attention	150 microseconds per channel, maximum 1.5 milliseconds per 8 channels.

■ Output range

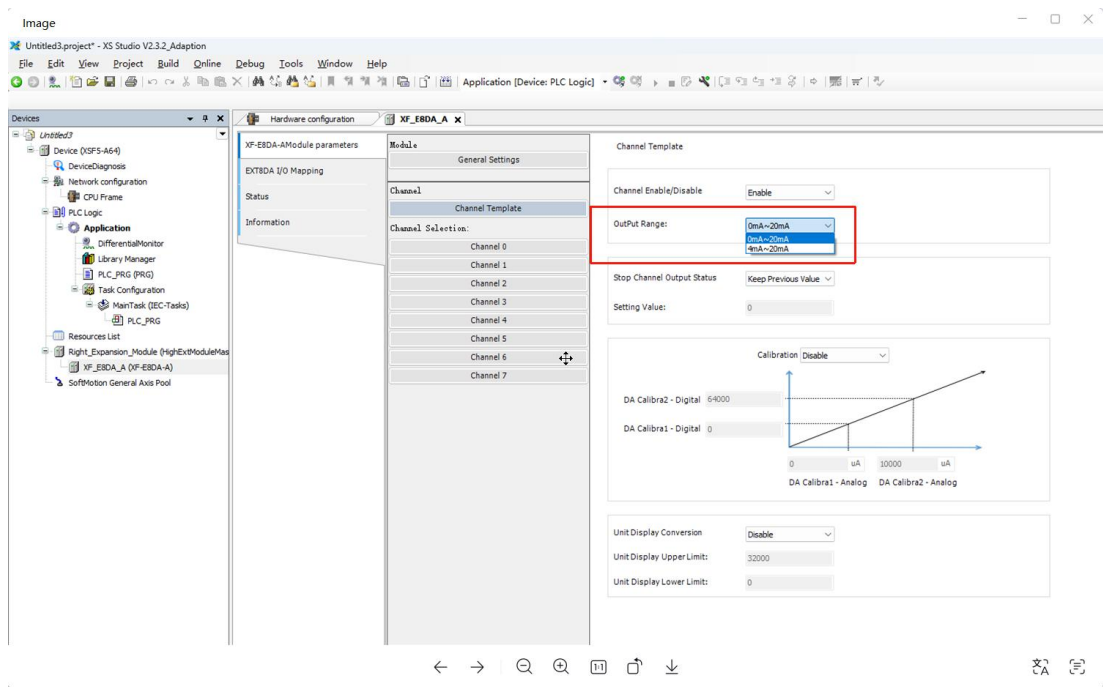

Can choose different output ranges.

Parameters can be set	The parameters that can be set are illustrated through the drop-down box.
Default parameters	0~20mA
current measurement range	0mA~20mA、4mA~20mA

■ Under Stop : Output status of the lower channel

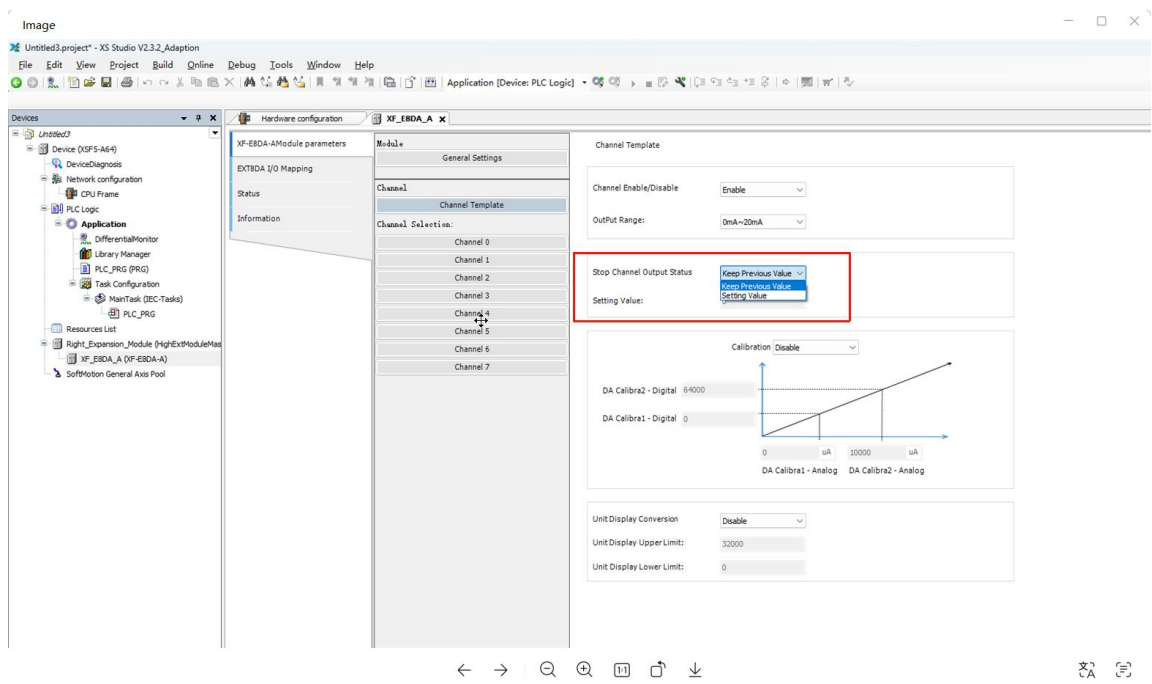

- When the CPU unit is in the STOP mode or in the abnormal error mode, the corresponding DA channel of the module outputs according to the set parameters.

Settable parameters	The parameters that can be set are illustrated through the drop-down box.
Default parameters	Maintain the previous value
Output status of the lower channel when stopped	Maintain the previous value and the set value

- scope:

Current output range	0~20mA	4~20mA
Set value	0~64000	12800~64000

■ Calibration function

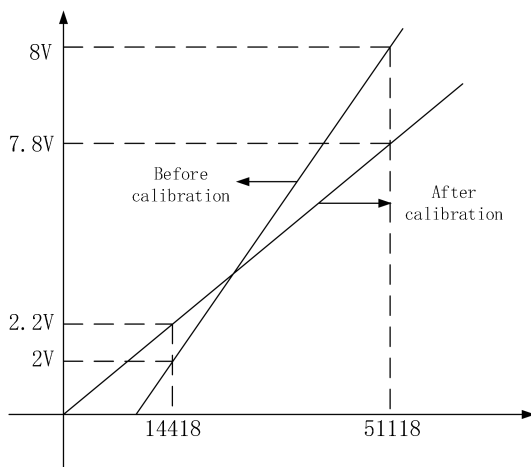
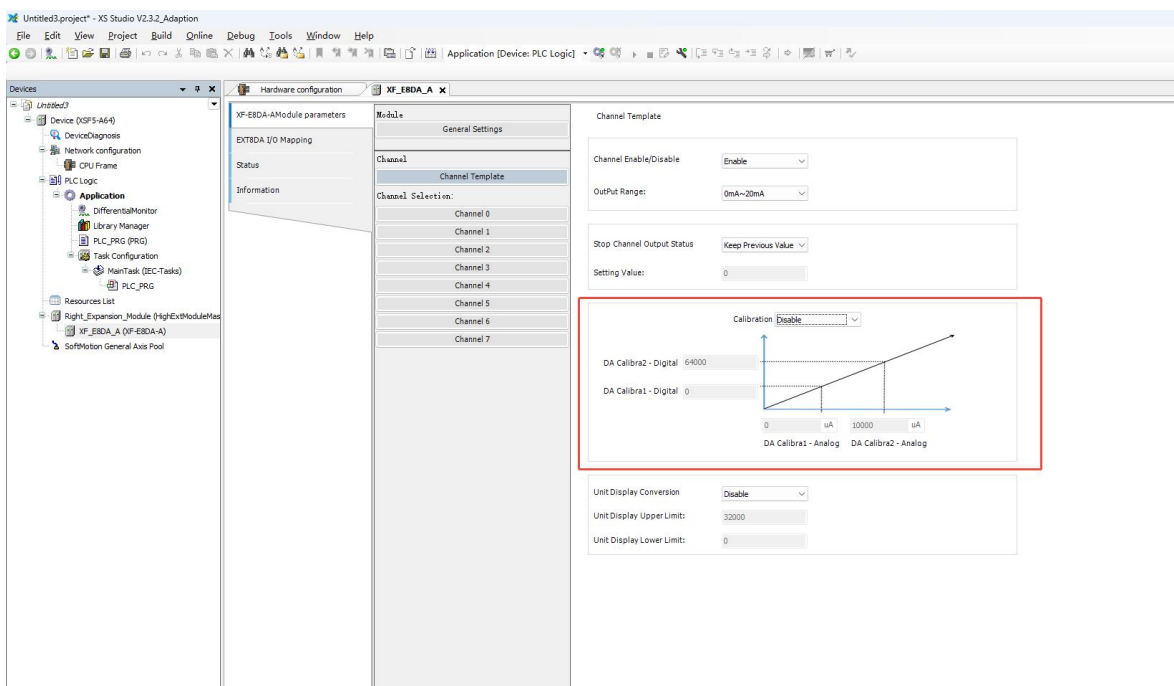

Support users to calibrate by setting the DA calibration function. The calibration result will be immediately reflected in the scale ratio value (digital calculation value), and the calibration can be easily completed by oneself during system startup.

- parameters are adjustable
 - ◆ Enable/Disable (default: disabled).

- ◆ Once the output range of the module is selected, the analog and digital outputs of Calibration 1 and 2 will correspond to different ranges.

Output current range	0~20mA	4~20mA
Calibration 1,2: Analog range calibration; Calibration 1,2: Digital range calibration	0~20000uA	4000~20000uA
Calibration 1,2: Analog range calibration; Calibration 1,2: Digital range calibration	0~64000	12800~64000

■ Unit Conversion

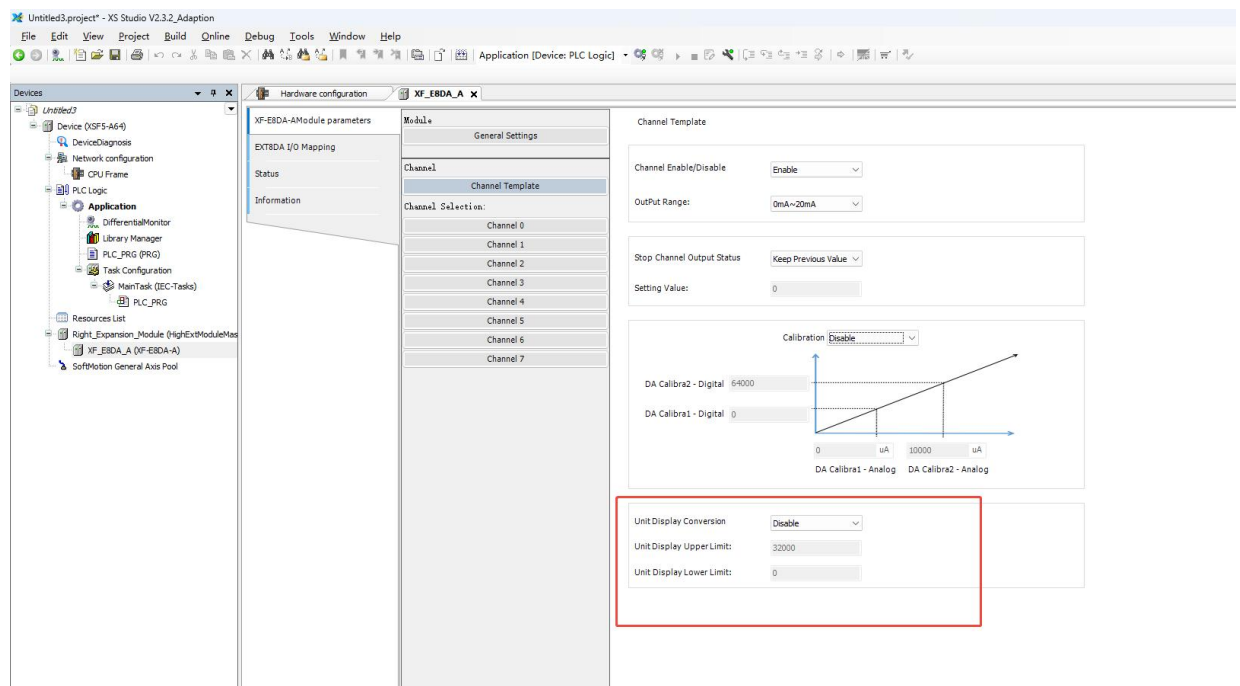

- This feature displays the output analog data directly in the actual units required by the customer.

7.7 Analog voltage output unit XF-E8DA-V

7.7.1 Product Overview

The XF-E8DA-V series analog voltage output expansion module features 8-channel analog voltage outputs and is compatible with XF/XSF series CPU units as well as XF series communication coupler units.

- 8-channel analog voltage output;
- Channel switching speed: 1.5 ms per 8 channels;
- Maximum 0.2% error;
- Design with a width of 12 mm.

■ Module Version

Hardware Version	Firmware Version	Function
H2	V2.0	The basic functions have been officially put into operation for the first time.

7.7.2 Module View

1) Description of each part

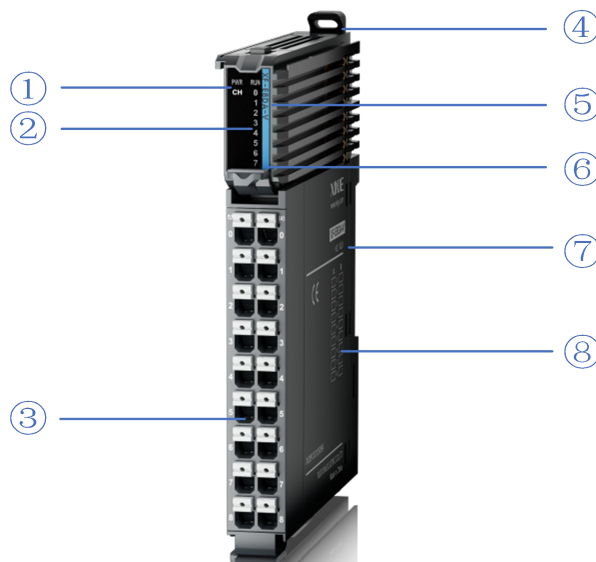

Number	Name	Nnumber	Name
①	System LED indicator lights	②	Channel LED indicator
③	Disconnectable terminal block	④	Fastener
⑤	Signal indication	⑥	Color coding for module type indication
⑦	Module hardware and Firmware version	⑧	Hookup

2) System Indicator Light

System Indicator Light	Meaning	
PWR (green)	Off	Module not powered on (backplane bus)
	Steady ON	All external power supplies for the module are functioning normally (backplane bus power and external 24V input).
	Flash 1Hz* ¹	Partial module power supply is abnormal and cannot operate normally (external)
RUN (green)	Steady ON	The module is running normally
	Flash 1Hz* ¹	The module encountered a general error in the log
	Off	The module encountered a critical error in the log
	10Hz* ²	Modeling communication



- *1: The duty cycle is 50%, and the frequency is 1Hz, with a square wave.
- *2: The duty cycle is 50%, and the frequency is 10Hz, with a square wave.

3) Channel Indicator Light

Model	Channel indicator light		
XF-E8DA-V	CH0~CH7	Steady ON (green)	The channel is enabled and configured correctly
		Flash 10Hz	This channel has error information
		Off	Forbidden channel

4) Color Identification

Number	Color	Module type
1	Grey White	Digital input
2	Gray	Digital output & digital mixing module
3	Light blue	Analogue input
4	Light blue	Analog output
5	Green	232&485 serial communication
6	Pink	Temperature signal input
7	White	High speed counting
8	Purple	Pulse output
9	Red	Repeater power supply

7.7.3 General Specifications

Project		Description
Operating temperature	Max temperature	55°C
	Min temperature	-20°C
Transportation/Storage Temperature	Max temperature	70°C
	Min temperature	-40°C
Environmental humidity (including operation/storage)	Upper limit	95%
	Lower limit	10%
Protection grade		IP20
Anti vibration		Complies with IEC61131-2 under intermittent vibration (frequency 5-9Hz, constant amplitude 3.5mm peak displacement) and (frequency 9-150Hz, constant acceleration 1.0g peak acceleration) The continuous shock vibration (5-9Hz, half amplitude 1.75mm displacement) and (9-150Hz, constant acceleration 0.5g, constant frame amplitude) Scan 10 times in each of the X, Y, and Z directions
Impact resistance		Complies with IEC61131-2 standards; Impact intensity of 15G (peak) was applied for 11ms on each of three mutually perpendicular axes, with 3 impacts per axis (total 18 impacts).
Operating environment		Non-corrosive gases
Operating altitude		0-2000 meters
Overvoltage level		II: Complies with IEC61131-2
Pollution level		2: Complies with IEC61131-2
Anti interference EMC		Complies with IEC 61131-2 and IEC 61000-6-4 Type B
Relevant certifications		CE

7.7.4 Technical Specifications

7.7.4.1 Module Performance

Project		Description
Input channel		8
Analog input range(rated)	Input voltage range	0V~5V (0~64000) 0V~10V (0~64000)

Project		Description
		-5V~5V (-32000~32000) -10V~10V (-32000~32000) 1V~5V (12800~64000) 外部负载电阻 2KΩ~1MΩ
Maximum output Enter range	Output voltage	DC±15V
Response speed		150 μs per channel, 1.5 ms per channel
Resolution ratio		1/64000 (16Bit)
Module power supply Source	Rated input	DC24V±10%, 150mA
	Protect	Reverse Connection Protection
Error	Room temperature: 25°C ± 5°C	±0.1%(25±5 °C)
	Full temperature range: -20 to 55°C	±0.2%
Insulate		Channel is not isolated; power supply is isolated
Module dissipation		0.8 W (internal backplane) + 0.85 W (external input)
Module weight		88g

7.7.4.2 Module Conversion Diagram

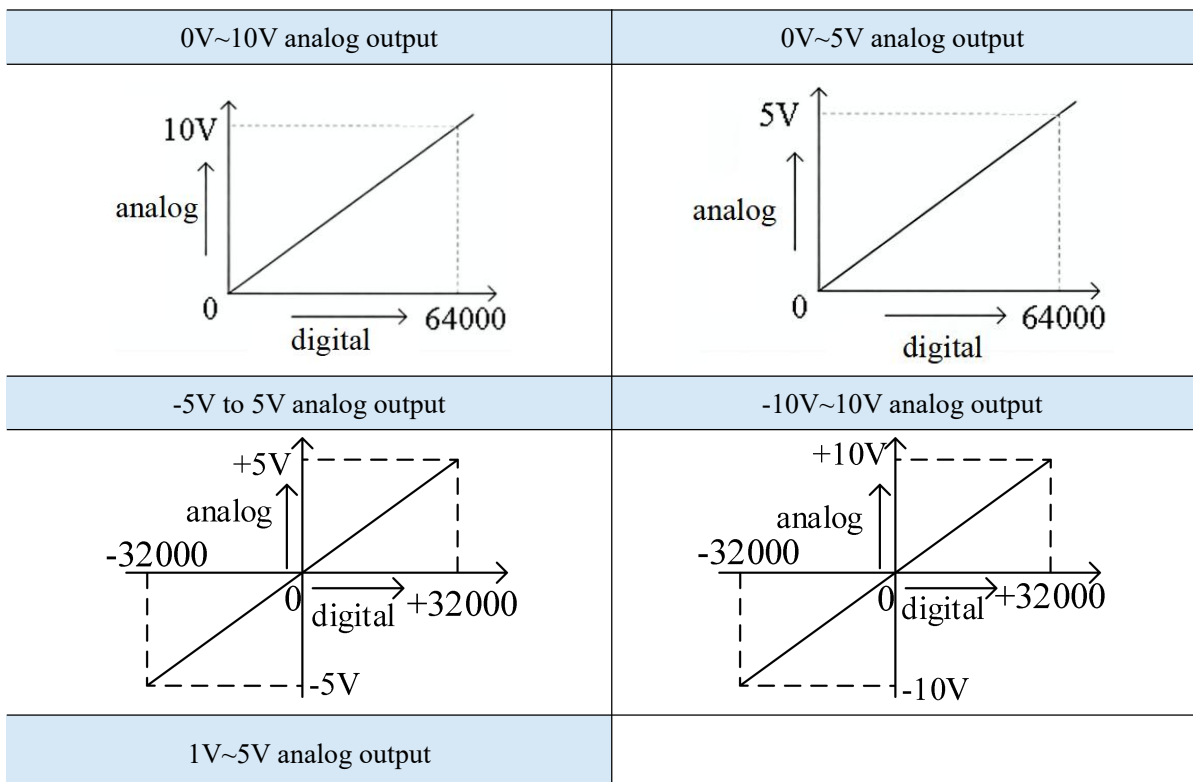

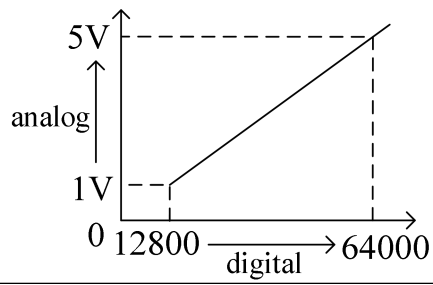

7.7.5 Installation & Wiring

7.7.5.1 Appearance dimensions

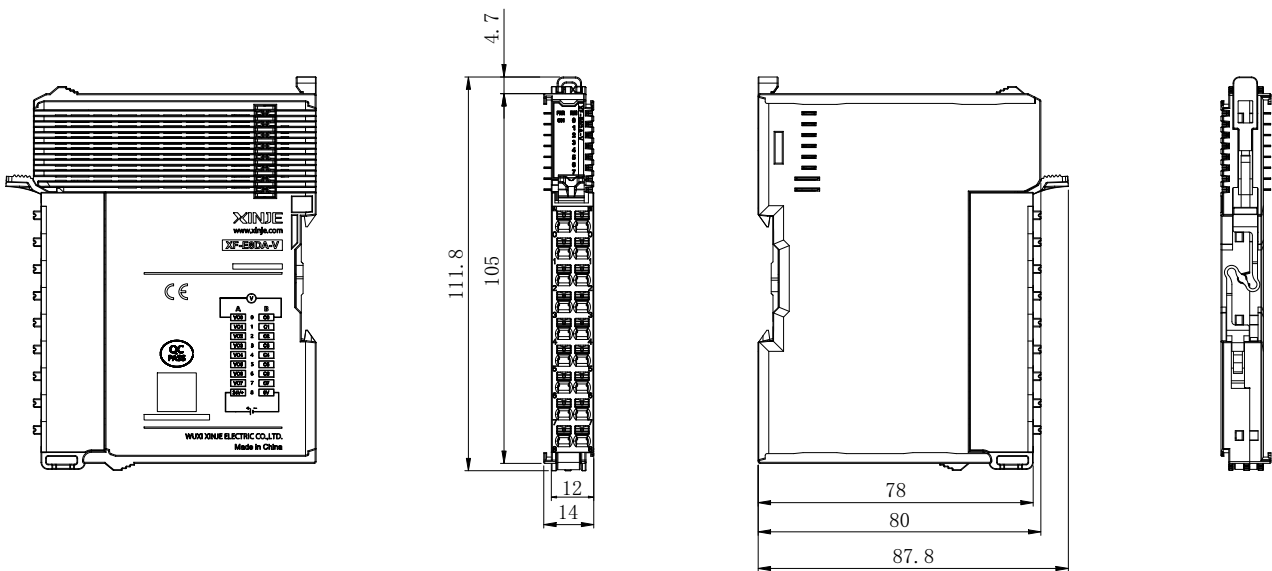

(unit: mm)

7.7.5.2 Terminal Definitions & Wiring

1) Terminal definition

XF-E8DA-V				
Meaning	A terminal	Terminal arrangement	B terminal	Meaning
CH0-DA Analog Voltage Output Terminal	0		0	CH0 – Common Output Terminal
CH1-DA Analog Voltage Output Terminal	1		1	CH1-Common Output Terminal
CH2-DA Analog Voltage Output Terminal	2		2	CH2-output common terminal
CH3-DA Analog Voltage Output Terminal	3		3	CH3 Output Common Terminal
CH4-DA Analog Voltage Output Terminal	4		4	CH4 Output Common Terminal
CH5-DA Analog Voltage Output Terminal	5		5	CH5-output common terminal
CH6-DA Analog Voltage Output Terminal	6		6	CH6-output common terminal
CH7-DA Analog Voltage Output Terminal	7		7	CH7 – Common Output Terminal
The external component receives a 24V power supply with positive polarity.	8		8	The external component is supplied with a 24V negative power supply.

2) External wiring

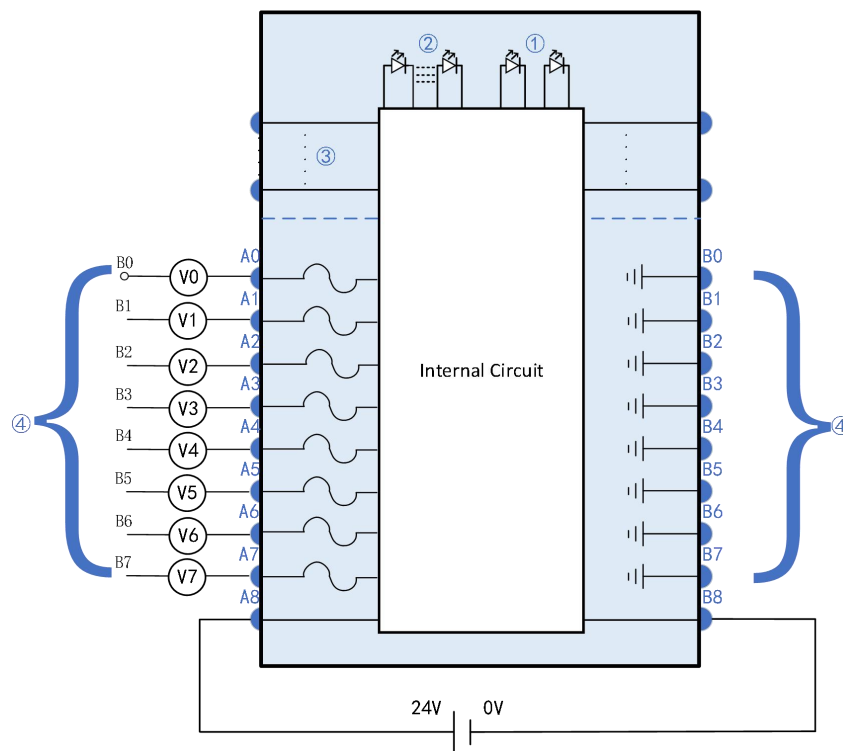

- ①System Indicator Light ②Channel indicator light ③backplane bus ④Output channel & wiring light

7.7.5.3 Installation Method

1) Installation requirements

The module is mounted using DIN rails that must comply with the IEC 60715 standard (35 mm wide, 1 mm thick). The dimensions are shown in the figure below, measured in mm.

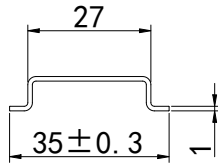

Attention

When the module is installed on a DIN rail that does not meet the recommended specifications, the DIN rail lock may fail to engage properly.

2) Installation Steps

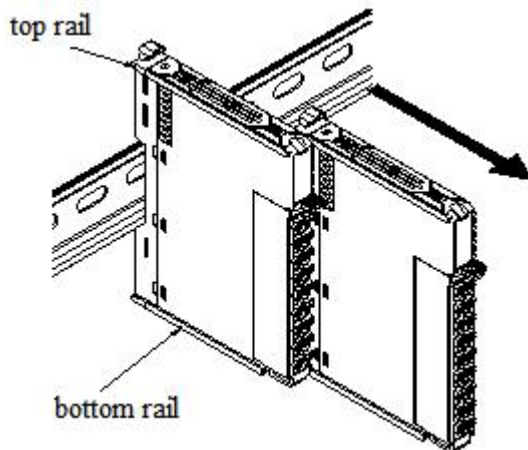

1. The IO modules are assembled by sliding along the top and bottom rails, as shown in the left figure.

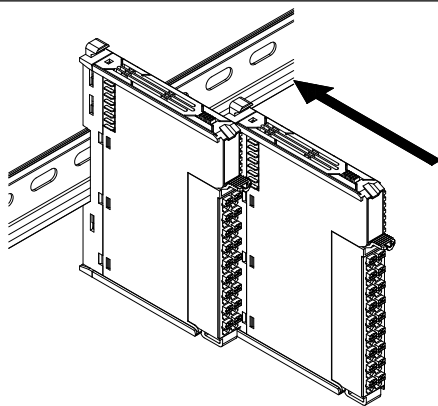

2. The module is mounted on the guide rail. During installation, align the module with the DIN guide rail and press it in the direction indicated by the arrow. A clear clicking sound will be heard when the module is properly secured, as shown in the left image.

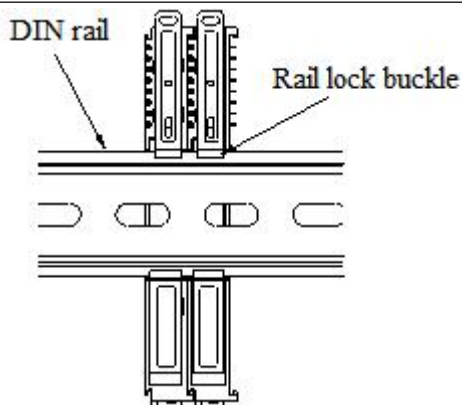

3. After module installation, the latch will automatically lower to lock. If it fails to move down, press the top of the latch downward to ensure proper installation.

3) Disassembly steps

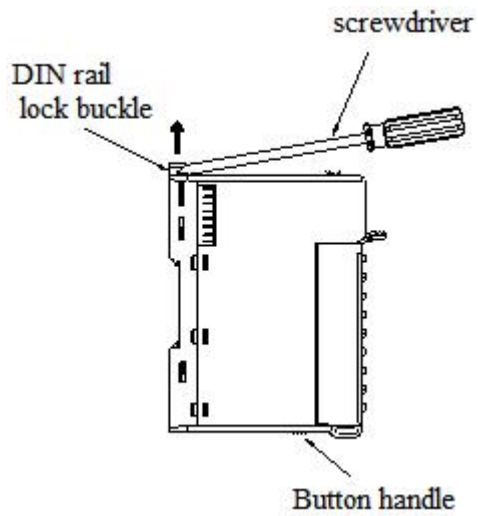

1. Use a screwdriver or similar tool to pry up the guide rail lock, as shown in the left image:

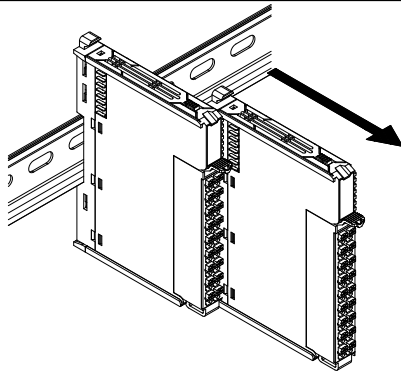

2. Pull the module straight forward from the buckle position (the raised part), then press down the top of the buckle as shown in the left image.

7.7.5.4 Installation Environment

This product supports four installation orientations: horizontal, vertical, top-mounted on electrical cabinets, and bottom-mounted. Horizontal installation is recommended. The cooling system utilizes natural convection. To ensure proper ventilation and heat dissipation while maintaining sufficient wiring clearance, a minimum clearance must be maintained around the product, as shown in the figure below.

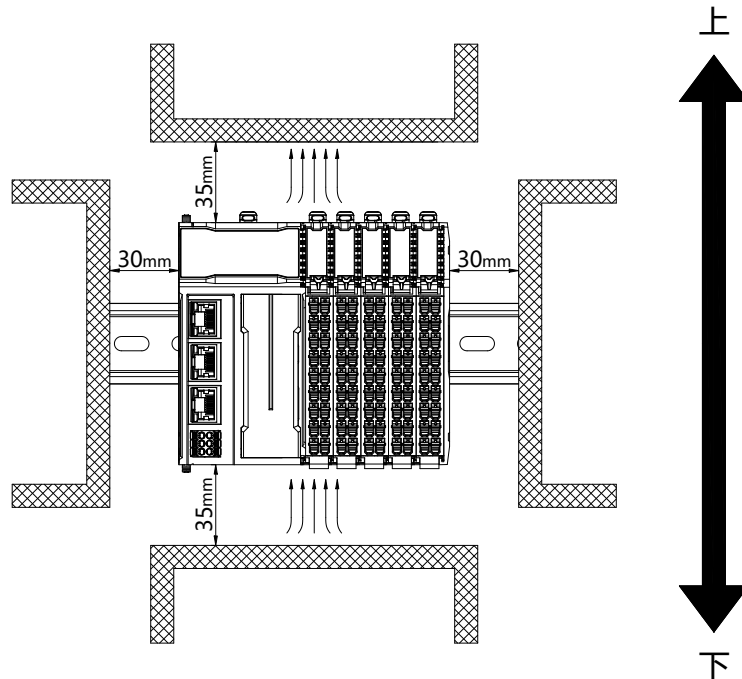

If the product is surrounded by high-temperature heat source equipment (heaters, transformers, high-resistance components, etc.), maintain a minimum clearance of 100mm between the product and such equipment.

7.7.5.5 Equipment Wiring

When wiring the module, its connectors must meet the following requirements:

Suitable wire gauge	
National standard/mm ²	American-Standard /AWG
0.3	22
0.5	20
0.75	18
1.0	18
1.5	16

If using other wire-type terminal lugs, press them onto the stranded wire as shown in the figure below for shape and size requirements.

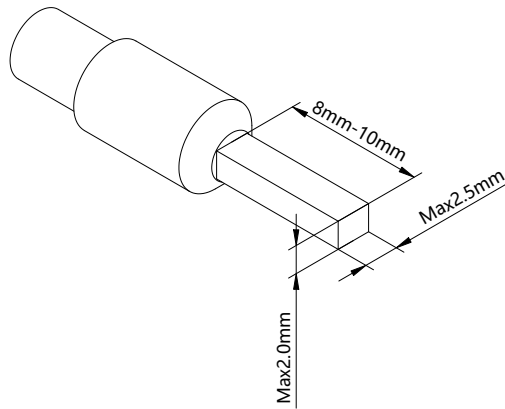

7.7.6 Parameters and Mapping Addresses

Name	Type	Explanation
XF-E8DA-V	Stuct	8-channel output module
CH0	DINT	Channel 0 output value
CH1	DINT	Channel 1 output value
CH2	DINT	Channel 2 output value
CH3	DINT	Channel 3 output value
CH4	DINT	Channel 4 output value
CH5	DINT	Channel 5 output value
CH6	DINT	Channel 6 output value
CH7	DINT	Channel 7 output value
ErrCode_module	WORD	Module-level error code
ErrCode_CH	DWORD	Channel level error code

■ Error code parameter

Module-level error code (ErrCode_module)		
Bit position	meaning	Error level
0	The 24V input power of the module is abnormal.	Critical
2	An internal module error occurred and the user layer cannot fix it	Critical
3	Version mismatch	Critical
4	ADC/DAC read/write failure	Critical

7.7.7 Functions and Settings

■ Module Power Supply Detection

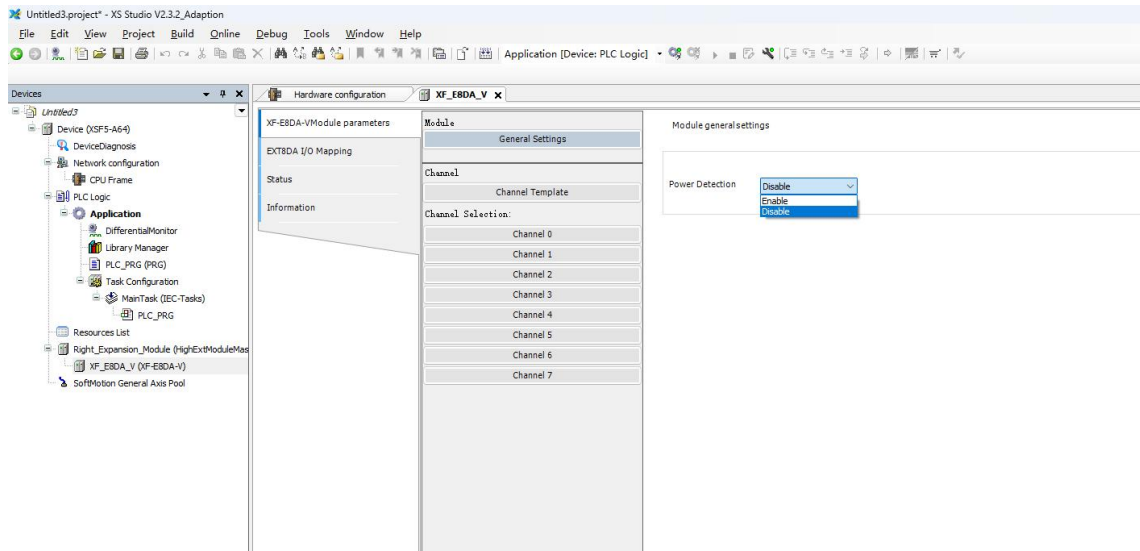

- Check whether the external 24V power supply for the detection module is functioning properly:
 - ◆ Normal: The module is operating normally;
 - ◆ Abnormality: The module channel is unavailable but can be configured, set up, and scanned normally.

Parameters can be set	Enable/Disable (disabling this option prevents you from configuring subsequent software functions for the corresponding channel)
Default Parameters	Forbidden

■ Channel Enable/Disable

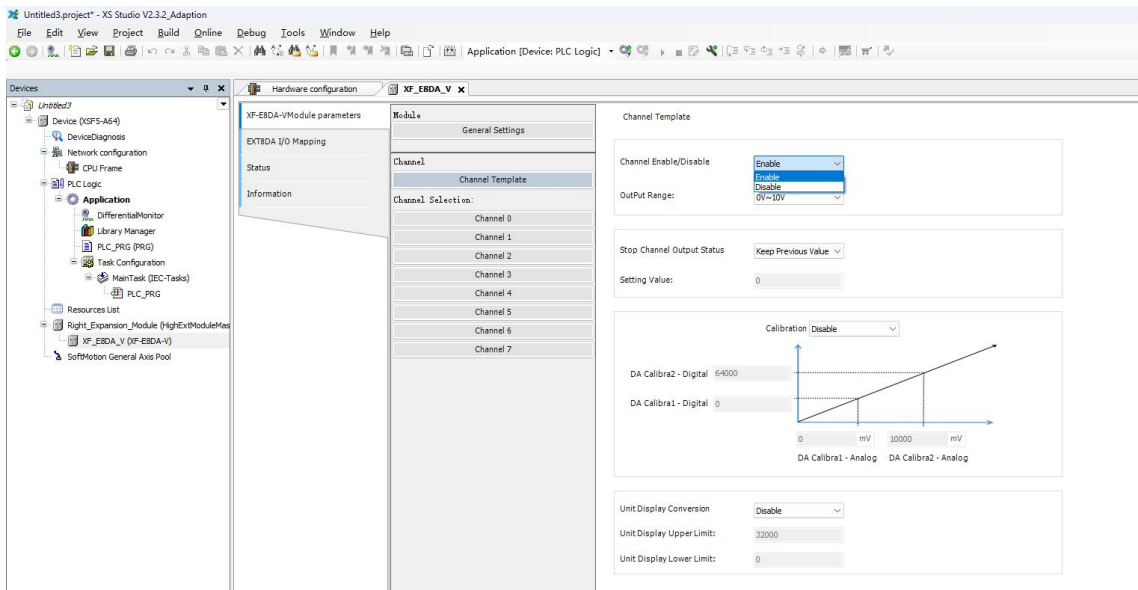

- Enable or disable the DA output channel to save module sampling time.

Parameters can be set	Enable or disable (After disabling, you cannot configure subsequent software functions for the corresponding channel)
Default parameters	start using
Matters need attention	150 μ s per channel; up to 1.5 ms per 8 channels.

■ Output range

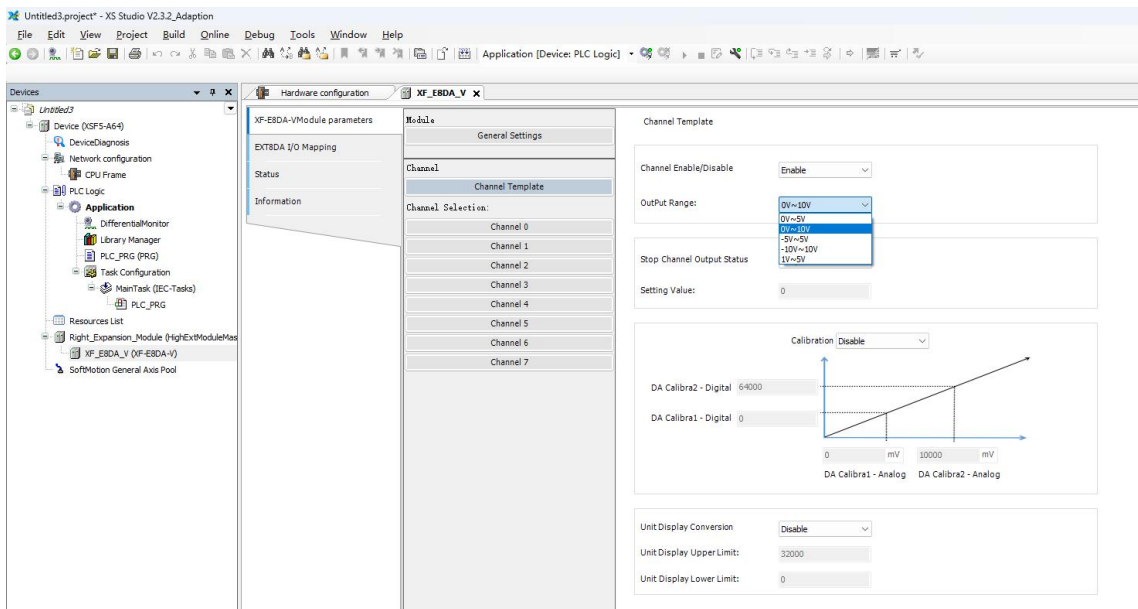

- You can choose different output ranges.

Parameters can be set	The table below shows configurable parameters: voltage and current
-----------------------	--

Default parameters	0V~10V
Voltage measurement range	0V~5V、0V~10V、-5V~5V、-10V~10V、1V~5V

■ Stop output

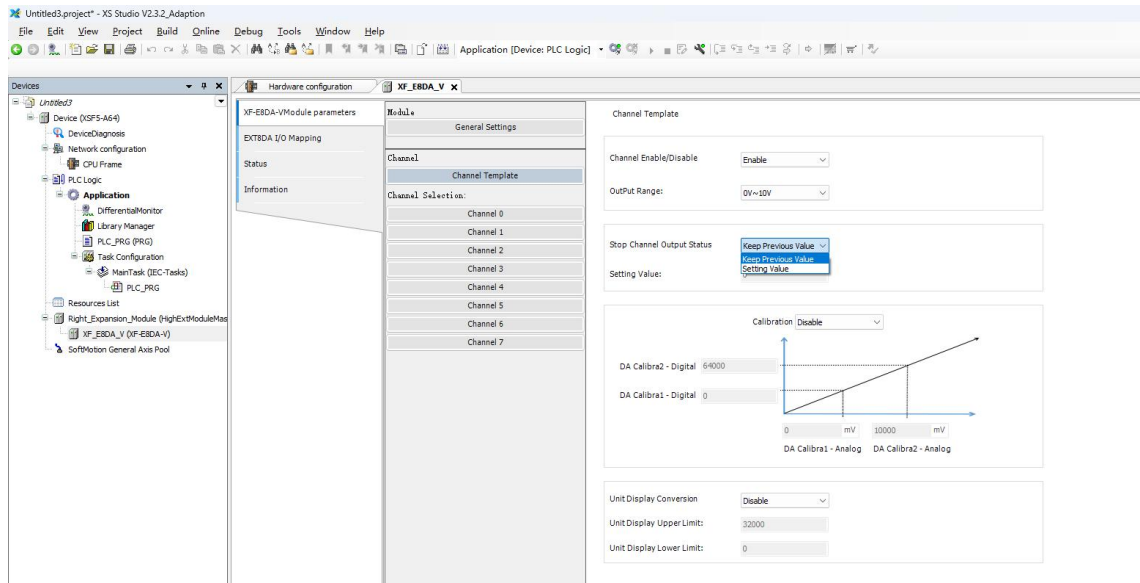

- When the CPU unit is in STOP mode or abnormal error mode, the corresponding DA channel of the module outputs data according to the set parameters.

Parameters can be set	The following scroll-down method demonstrates configurable parameters
Default Parameters	Keep the previous value
Stop the output status of the channel	Keep previous value, set new value

- Scope:

Output Voltage Range	0V~5V	0V~10V	-5V~5V	-10V~10V	1V~5V
set value	0~64000	0~64000	-32000~32000	-32000~32000	12800~64000

■ Calibration Function

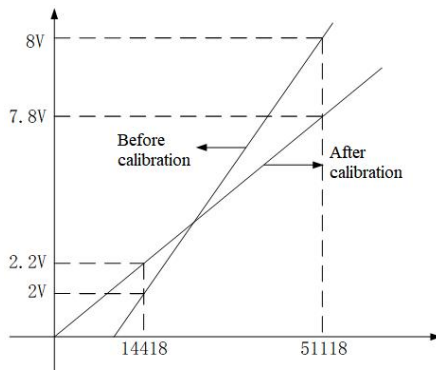
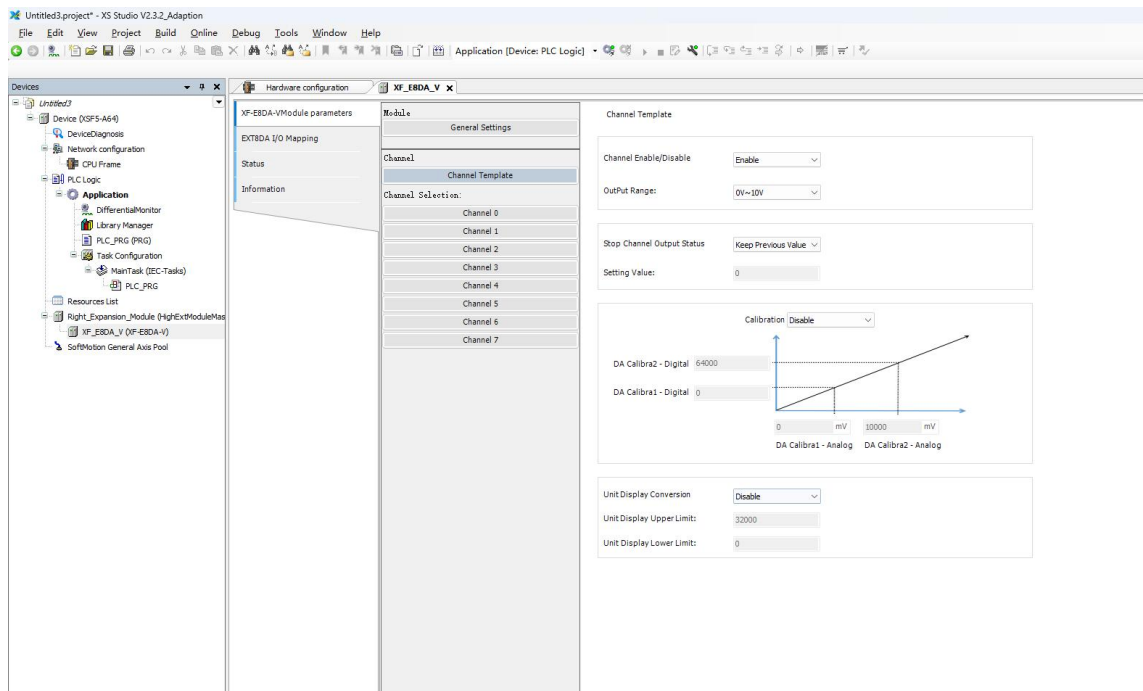

Users can calibrate by enabling the DA calibration feature, with immediate reflection in scaling values (digital calculations), allowing easy self-calibration during system startup.

- ◆ izable Parameters
- ◆ Enable/Disable (default: disabled).
- ◆ When the module's output range is selected, the analog and digital outputs of Calibration 1 and 2 will have different ranges.

Output Voltage Range	0~5V	0~10V	-5~5V	-10~10V	1~5V
Calibration 1 and 2: Analog Range	0~5000mV	0~10000mV	-5000~5000mV	-10000~10000mV	1000~5000mV
Calibration 1 and 2: Digital Range	0~64000	0~64000	-32000~32000	-32000~32000	12800~64000

■ Unit Display Conversion

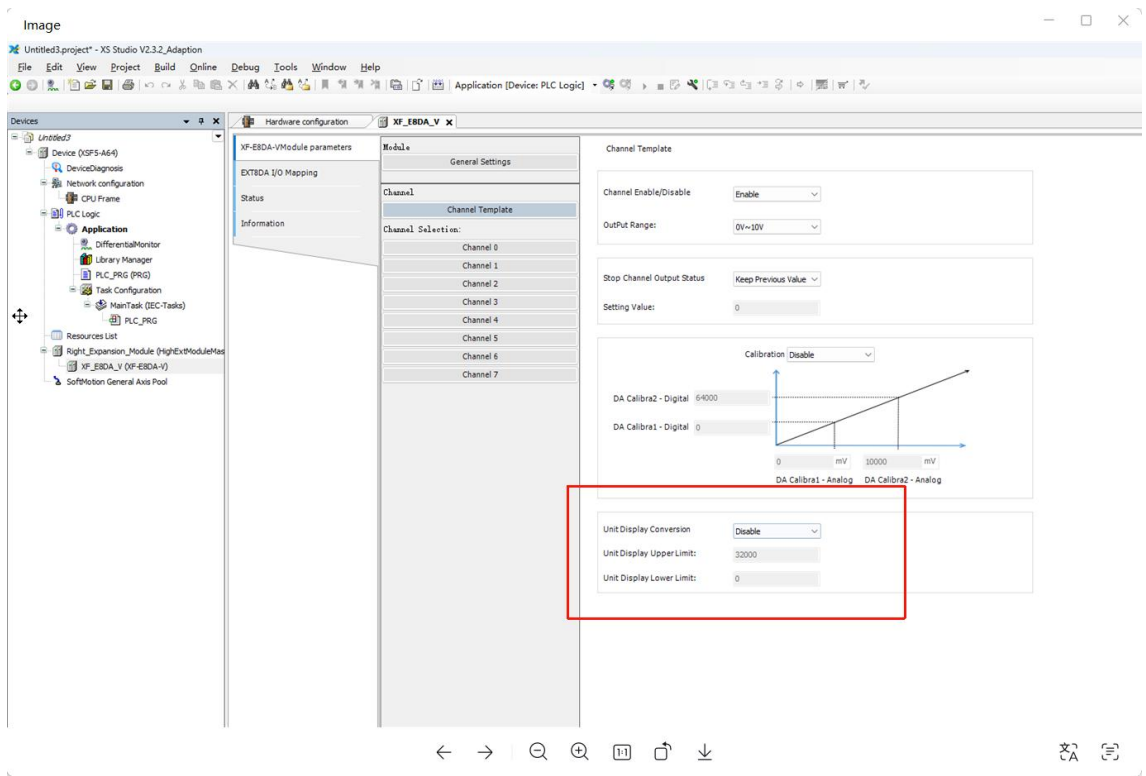

This feature displays the output analog data directly in the actual units required by the customer.

8. Serial Communication Module Unit

8.1 Naming Rules

$\frac{\text{XF}}{\textcircled{1}} - \frac{\text{E}}{\textcircled{2}} \frac{\textcircled{3}}{\text{O}} \frac{\textcircled{4}}{\square} \frac{\textcircled{5}}{\text{O}}$

①	Series name	XF: XF series expansion module
②	referential extension module	E: Right Extension Module
③	number of channels	1: 1 channel 2: 2 channel 4: 4 channel
④	Communication type	COM: serial communication CAN: CAN communication
⑤	Physical interface type	24: 232&485 2: 232 4: 485

8.2 Serial Communication Unit XF-E2COM24

8.2.1 Product Overview

The XF-E2COM24 series serial communication expansion module features two serial channels, supporting 232 and 485 communication protocols (each channel can only use one of these protocols). It is compatible with XF and XSF series CPU units, as well as XF series communication coupler units.

- 2 independent 232/485 serial communication channels;
- Supports Modbus master-slave communication and free-form communication;
- The channel and internal isolation treatment improve the Anti-interference;
- 12mm width design.

■ Module Version

Hardware version	Firmware version	function
H2.0	V2.0	The basic functions are now officially operational for the first time.



The PLC main unit supports up to 8 XF-E2COM24 serial modules on the right side, while each remote I/O adapter (LFC3-AP or LFP3-AP) can connect up to 8 such modules.

8.2.2 Module View

1) Explanation of each section

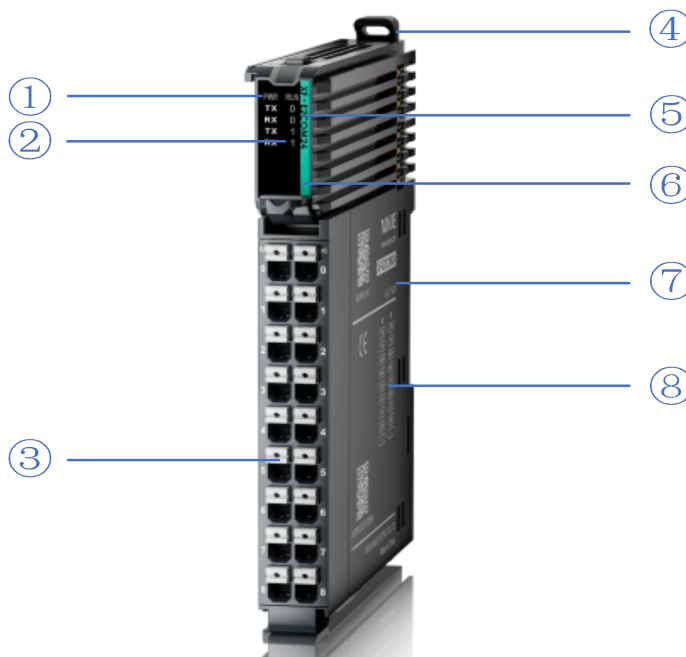

Number	name	Number	name
--------	------	--------	------

Number	name	Number	name
①	System LED indicator lights	②	Channel LED indicator light
③	disconnectable terminal block	④	fastener
⑤	model indication	⑥	Color code for indicator module type
⑦	Module hardware and Firmware version	⑧	hookup

2) System Indicator Light

System Indicator Light	meaning	
PWR (green)	extinct	The module is not powered on
	Always on	All power supplies for the module are functioning normally.
RUN (green)	Always on	The module is running normally
	Flash 1Hz* ¹	The module encountered a general error in the log* ³
	extinct	The module encountered an Critical error in the log* ⁴
	10Hz* ²	Modeling communication



- *1: The duty cycle is 50%, and the frequency is 1Hz, with a square wave.
- *2: The duty cycle is 50%, and the frequency is 10Hz, with a square wave.
- *3: Common errors that do not affect device operation.
- *4: Critical error causing device malfunction. Currently, only configuration parameter errors exist.

3) Channel indicator light light

model	Channel indicator light		
XF-E2COM24	RX0	Always on (green)	Receiving data
	RX1	go out	Received completed or no communication
	TX0	Always on (green)	Sending data
	TX1	go out	Send completed or no communication

In normal communication, the RX/TX alternates between Flash, and the Flash speed can represent the communication rate.

4) Color labels

Number	Color		Module type
1		hoar	digital input
2		gray	digital output & digital mixing module
3		wathet	read analogue input
4		mazarine	analog output
5		green	232&485 serial communication
6		rose hermosa	Temperature signal input
7		white	high speed counting

Number	Color	Module type
8	purple	pulse output
9	red	repeater power supply

8.2.3 General Specifications

project		specifications
Operation temperature	Maximum temperature	55°C
	Minimum temperature	-20°C
Transportation/Storage Temperature	Maximum temperature	70°C
	Minimum temperature	-40°C
Environmental humidity (including operation/storage)	superior limit	95%
	lower limit	10%
Levels of protection		IP20
Anti-vibration		Complies with IEC61131-2 under intermittent vibration (frequency 5-9Hz, constant amplitude 3.5mm peak displacement) and (frequency 9-150Hz, constant acceleration 1.0g peak acceleration) The continuous shock vibration (5-9Hz, half amplitude 1.75mm displacement) and (9-150Hz, constant acceleration 0.5g, constant frame amplitude) Scan 10 times in X, Y, and Z directions
Shock resistance		Complies with IEC61131-2 standard Impact force of 15g (peak) was applied for 11ms to three mutually perpendicular axes, with 3 impacts per axis (total 18 impacts).
Operating environment		Non-corrosive gas
Operating altitude		0-2000 meters
Overvoltage class		II: Complies with IEC61131-2
Pollution level		2; Complies with IEC61131-2
Anti-interference EMC		Complies with IEC 61131-2 and IEC 61000-6-4 Type B
Relevant certifications		CE

8.2.4 Technical Specifications

project		specifications
Number of ports		2
communication port		RS-232 and RS-485 (select one of the two single-channel COM ports for RS-232 or RS-485)
communicating protocol		Modbus-RTU/ASCII master-slave/free format
communication specification	communication mode	half-duplex
	channel separation	yes
	Baud rate	2400bps, 4800bps, 9600bps, 19200bps (default), 38400bps, 57600bps, 115200bps
	data bit	7 or 8 (default)
	stop bit	1 (default) or 2
	verification	Odd, Even (Default), None
haul up		RS-232 15 meters (19200bps) RS-485 1200 meters (9600bps)
Maximum module count		8 units (each main unit supports right expansion, and each remote IO adapter supports up to 8 units)
Maximum byte count		256 bytes (Modbus) 1024 bytes (Free format)
Module dissipation		0.8W

8.2.5 Installation & Wiring

8.2.5.1 Appearance dimensions

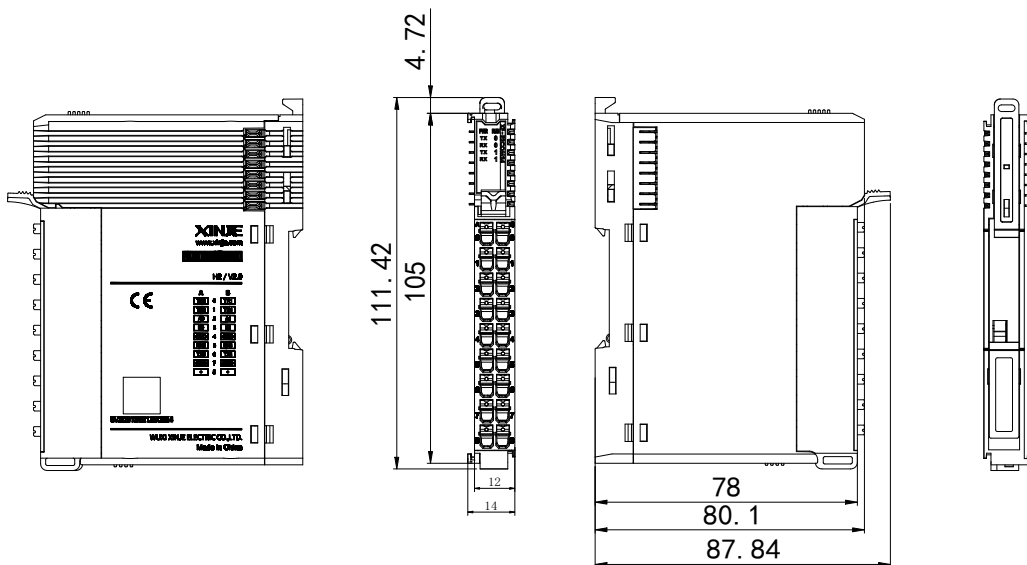

(unit :mm)

8.2.5.2 Terminal Definitions

XF-E2COM24				
meaning	A terminal	terminal arrangement	B terminal	meaning
TR0- A Terminal Resistance of Channel	0		0	TR1 - B channel terminal resistance
TR0- A Terminal Resistance of Channel	1		1	TR1 - B channel terminal resistance
A0- RS485 communication 485+ terminal	2		2	A1 - RS485 communication 485+ terminal
B0- RS485 communication 485 terminal	3		3	B1 - RS485 communication 485 terminal
GND - earth terminal	4		4	GND- earth terminal
RX0 -RS232 communication data receiving terminal	5		5	RX1- RS232 communication data receiving terminal
TX0 -RS232 communication data sending terminal	6		6	TX1-RS232 communication data transmitting terminal
GND - earth terminal	7		7	GND- earth terminal
.	8		8	.

8.2.5.3 Installation Method

1) Installation requirements

The module is mounted using DIN rails that comply with IEC 60715 standards (35mm wide, 1mm thick). The dimensions are shown in the figure below, with measurements in millimeters.

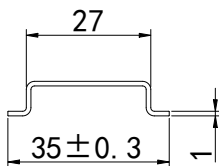

Attention

When the module is installed on a DIN rail not recommended above, the DIN rail latch may fail to lock properly.

2) Installation Steps

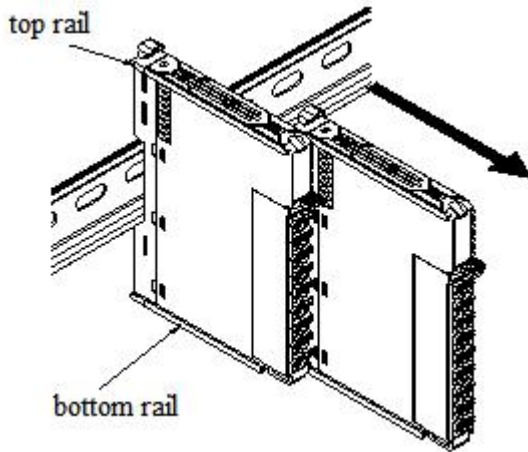

1. The IO modules are assembled by sliding along the top and bottom rails, as shown in the left figure.

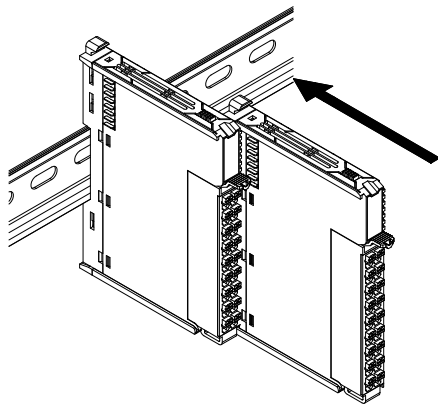

2. The module is mounted on the guide rail. During installation, align the module with the DIN guide rail and press it in the direction indicated by the arrow. A clear click sound will be heard when the module is properly secured, as shown in the left image.

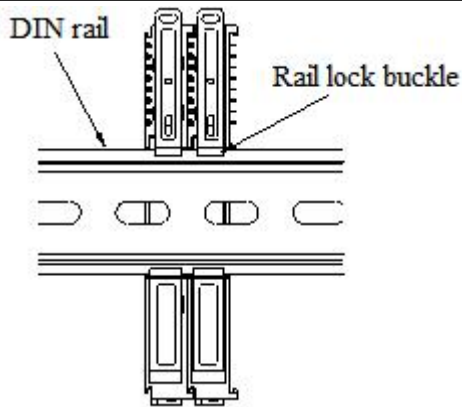

3. After module installation, the latch will automatically lower to lock. If it fails to move down, press the top of the latch downward to ensure proper installation.

3) Disassembly steps

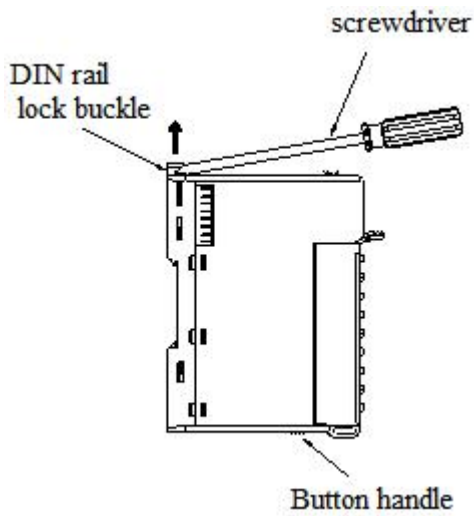

1. Use a screwdriver or similar tool to pry up the guide rail lock, as shown in the left image:

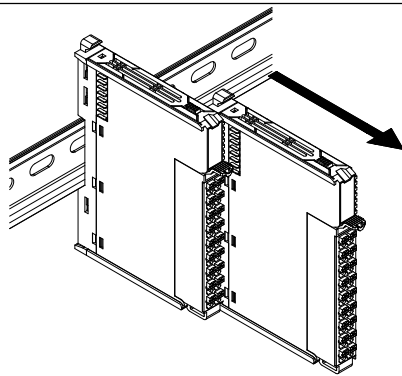

2. Pull the module straight forward from the buckle position (the raised part), then press down the top of the buckle as shown in the left image.

8.2.5.4 Installation Environment

This product supports four installation orientations: horizontal, vertical, top-mounted on electrical cabinets, and bottom-mounted. Horizontal installation is recommended. The cooling system utilizes natural convection. To ensure proper ventilation and heat dissipation while providing sufficient wiring space, a minimum clearance must be maintained around the product, as shown in the figure below.

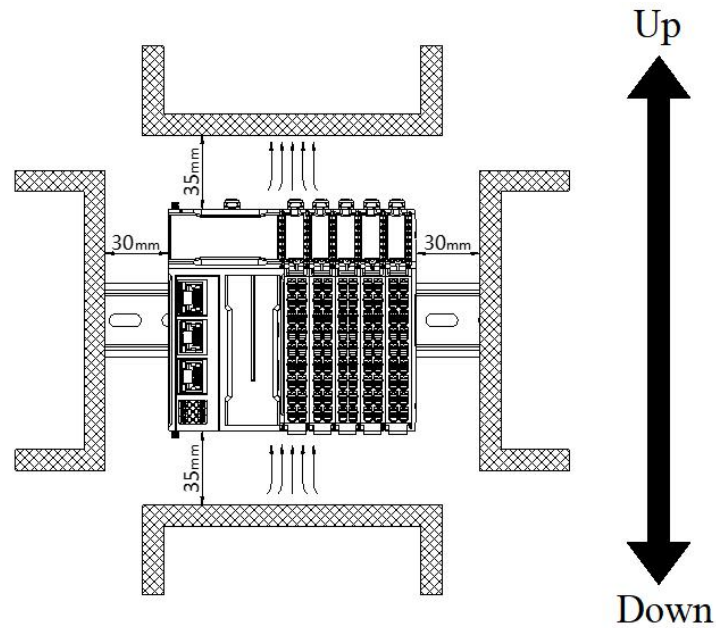

If the product is surrounded by high-temperature heat source equipment (heaters, transformers, large resistors, etc.), maintain a minimum gap of 100mm between the product and such equipment.

8.2.5.5 Equipment Wiring

When wiring the module, its connectors must meet the following requirements:

Suitable wire gauge	
National standard/mm ²	American-Standard /AWG
0.3	22
0.5	20
0.75	18
1.0	18
1.5	16

If using other wire-type terminal lugs, press them onto the stranded wire as shown in the figure below for shape and size requirements.

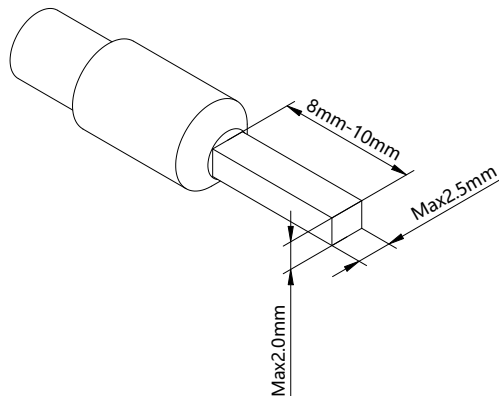

8.2.6 Functions and Settings

- channel enable

Selecting the corresponding "Channel Enable" allows configuration. If not selected, the parameter background appears gray and configuration is not allowed. When a serial port channel is configured, its data and the system parameters are synchronized to automatically configure the same parameters.

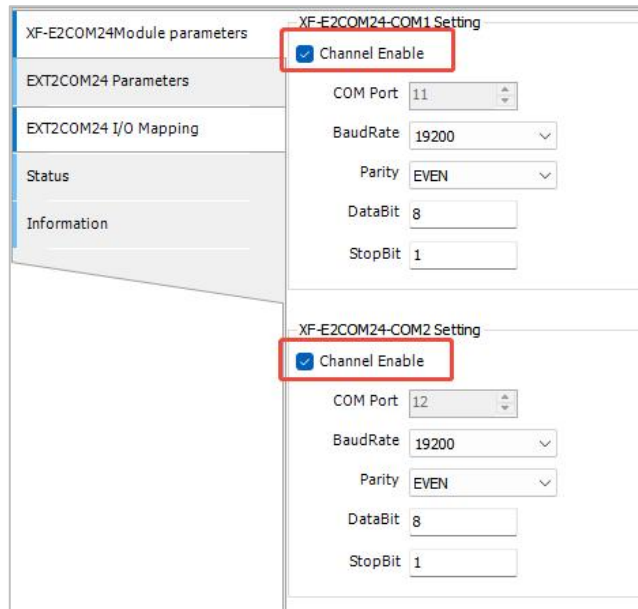

- COM port number

The controller body uses port numbers 1-10 for sorting, while the right expansion port numbers start from 11. Dragging to delete a module with an assigned port number will not rearrange the order.

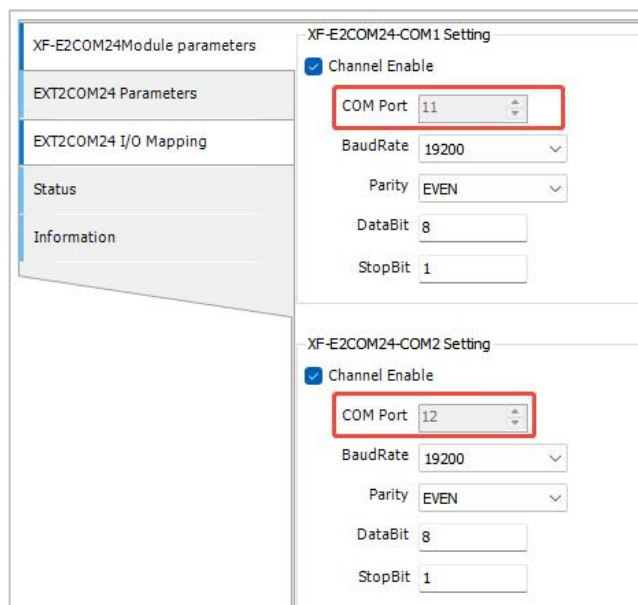



Native codesys enables addressing and sorting based on the specified port numbers.

■ Baud rate

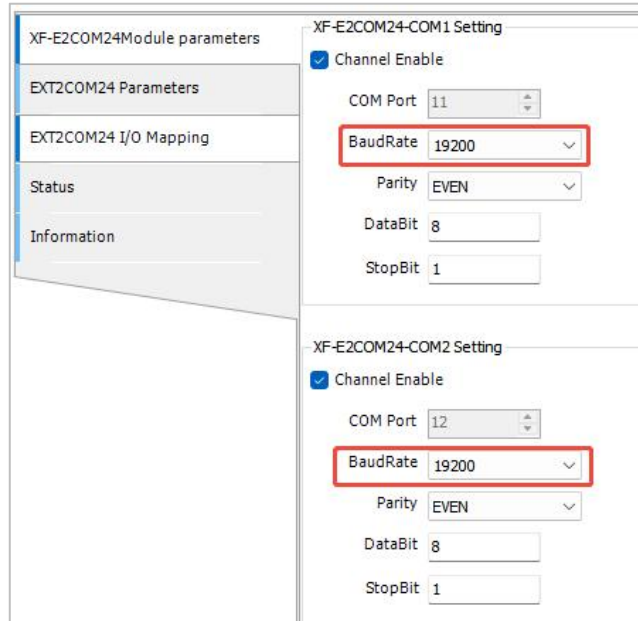

Set range	2400bps,4800bps,9600bps,19200bps,38400bps,57600bps,115200bps
Default parameter	19200bps

■ even-odd check

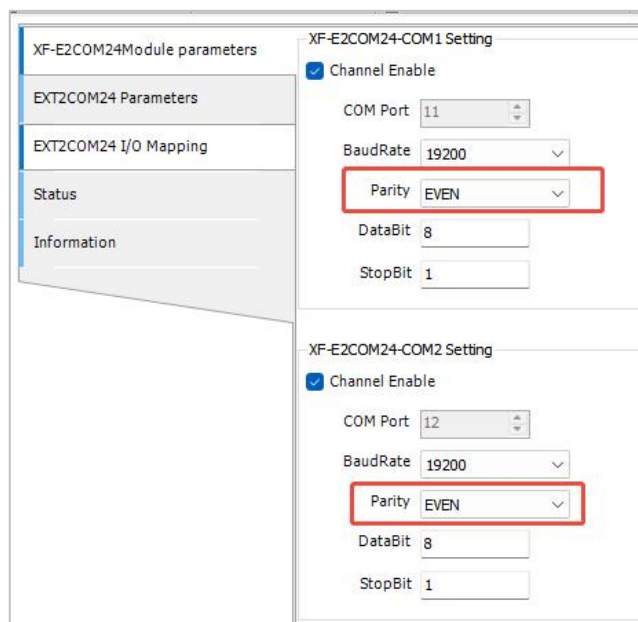

Set range	EVEN (even parity), ODD (odd parity), NONE (no parity)
Default parameter	EVEN (even parity)

■ data bit

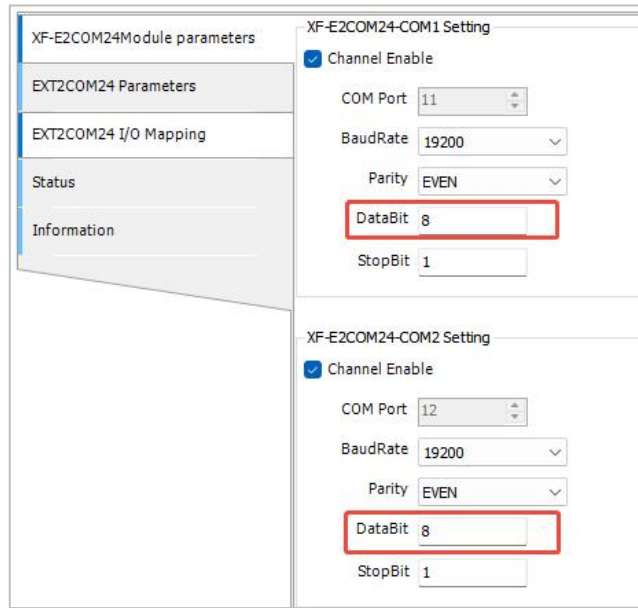

Set range	7 or 8
Default parameter	8

■ stop bit

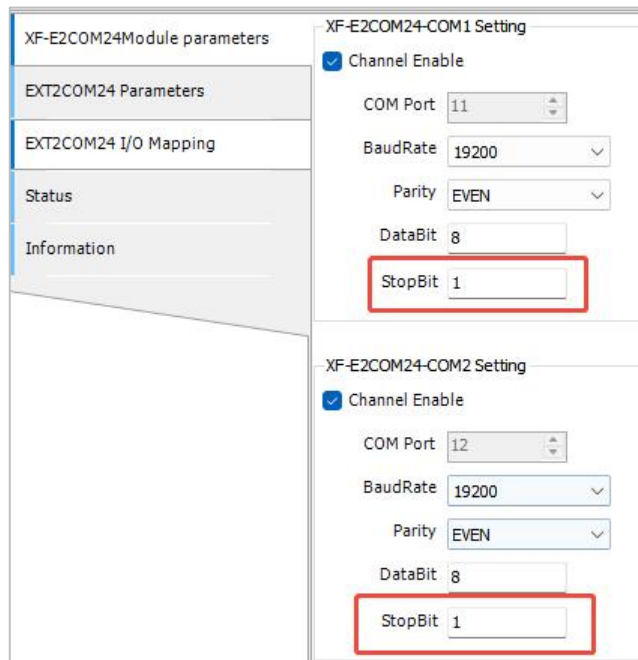

Set range	1 or 2
Default parameter	1

■ Module-level error code

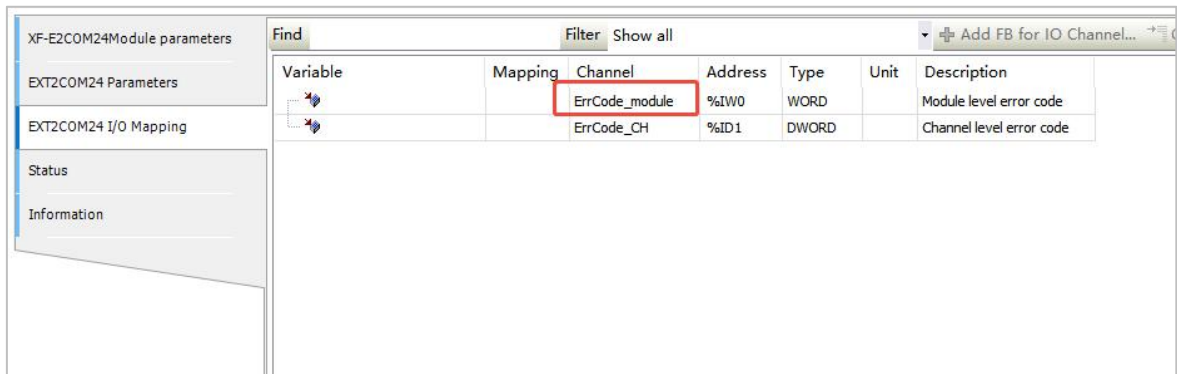

Module-level error code (ErrCode_module)		
Bit position	meaning	Error level
0	Version error	Critical
1	hardware error	Critical
2	running fault	Critical
3	parameter error	Critical

■ Channel level error code

Feature reservation.

8.2.7 Configuration Module

To add the right expansion module: First, double-click the space in the 'CPU Architecture' section. Then, in the 'Insert Host Module' dialog box that appears, select 'XF_E2COM24' to add the module, as shown in the figure below.

Configuring LF Series Remote I/O: For detailed configuration examples, refer to the LF Series Remote I/O User Manual.



8.2.7.1 MODBUS Master Station

Explanation :

As the master station, it supports up to 32 slave stations per channel.

The maximum data length a command channel can communicate:

FC	length
Read coil (01)	2000
Read input coil (02)	2000
Read register (03)	125
Read input register (04)	125
Write single coil (05)	1
Write to single register (06)	1
Write multiple coils (0F)	1968
Write multiple registers (10)	123
Read and write multiple registers (17)	Read: 125 Write: 121

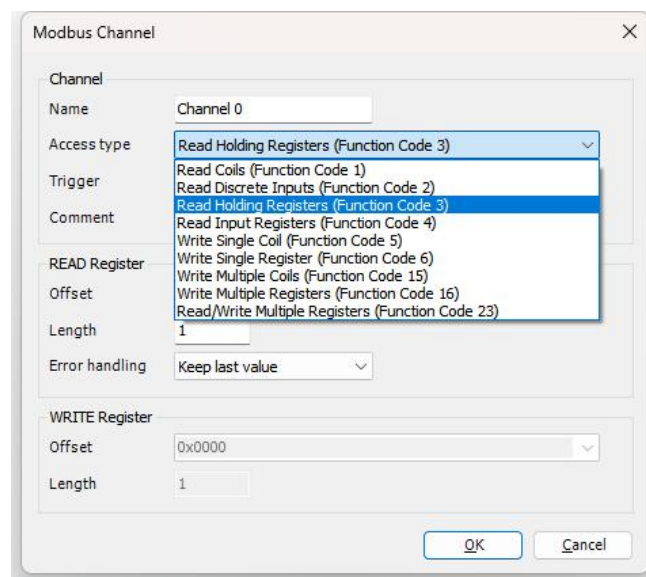

Double-click the "CPU Rack" to access the hardware configuration interface. You can configure the protocol for the module's two serial channels by checking the checkbox in the window, where selecting "MODBUS Master" is recommended.

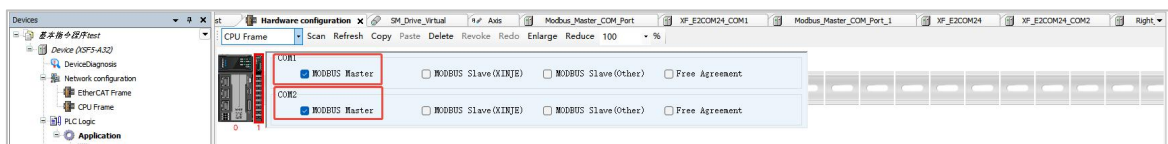

To configure the serial port as the master station, double-click "XF_E2COM24_COM" to access the Modbus communication settings interface, as shown below:

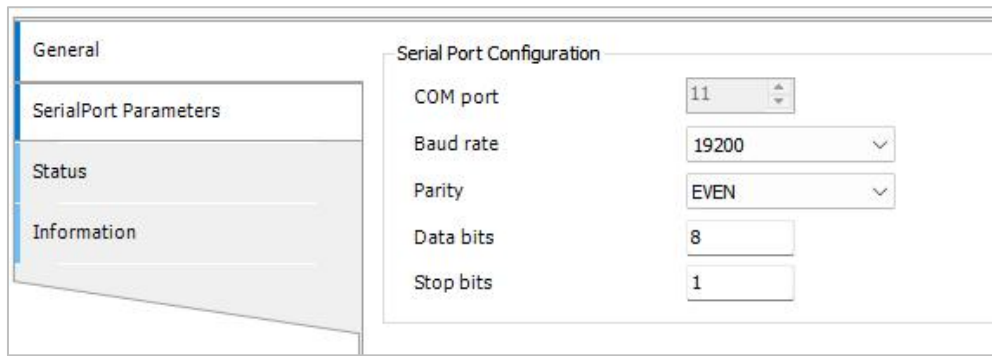

COM port	The master station's physical connection is selected as a serial port.
Baud rate	communication rate
even-odd check	communication frame check method
data bit	bits in a communication frame
stop bit	The last bit of a single packet in communication

Double-click the Modbus_Master_COM_Port master device in the device tree to open the Modbus master communication parameter configuration window. The configuration interface is shown in the figure.

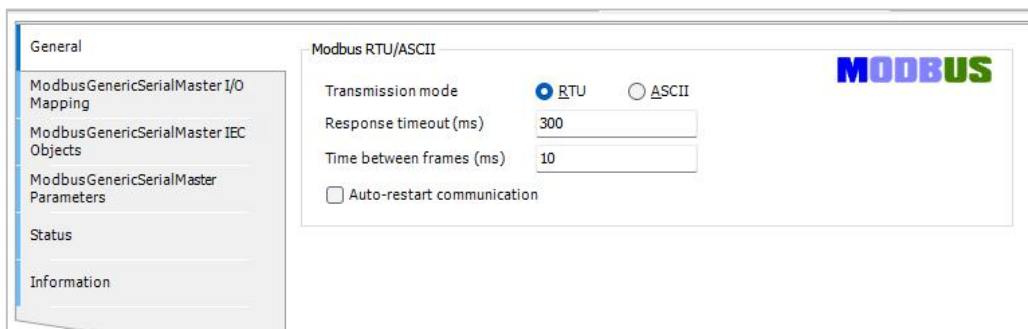

transmission mode	Select RTU or ASCII code
Response timeout (ms)	Specifies the time interval for the master station to wait for a slave station's response. If no response is received within this period, the master station will request the next slave station. The value entered here will be considered the default for each slave station. On the slave station configuration page, each slave station can set its own appropriate time interval.
Time between frames (ms)	Indicates the time interval between the master station receiving the previous response data frame and the next request data frame. This parameter can be used to adjust the data exchange rate.

After the configuration of the master station is finished, the corresponding configuration of the slave station connected to the master station is required.

After clicking the master device's "Modbus_Master_COM_Port", right-click and select "Add Device...". Choose the slave device and click "Add Device" to complete the setup. The slave device will now be added, as shown in the figure.

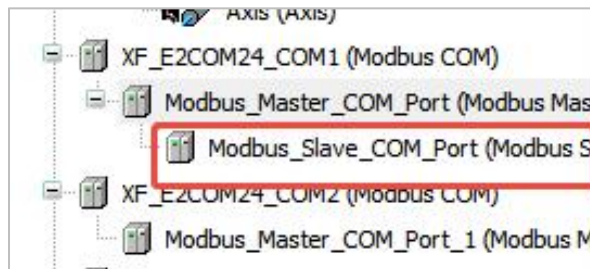
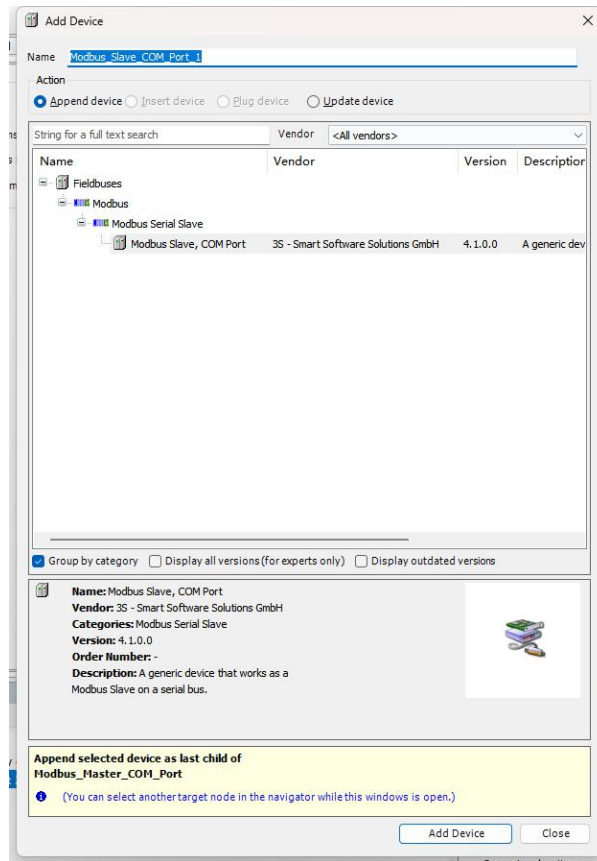
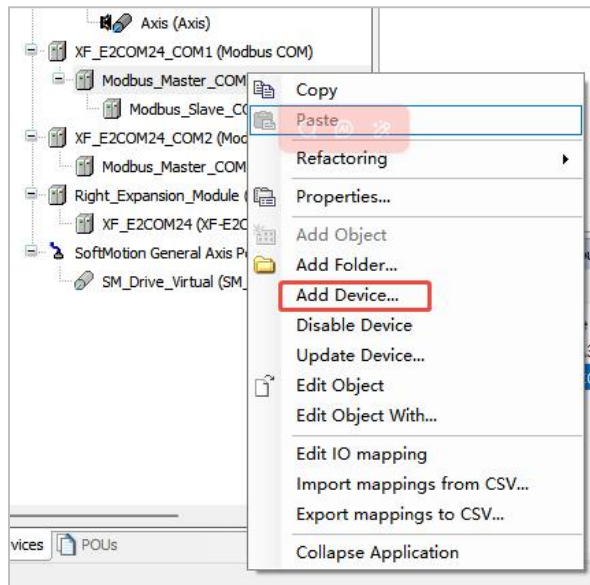

Double-click the Modbus_Slave_COM_Port node to access the slave configuration interface, as shown in the figure.

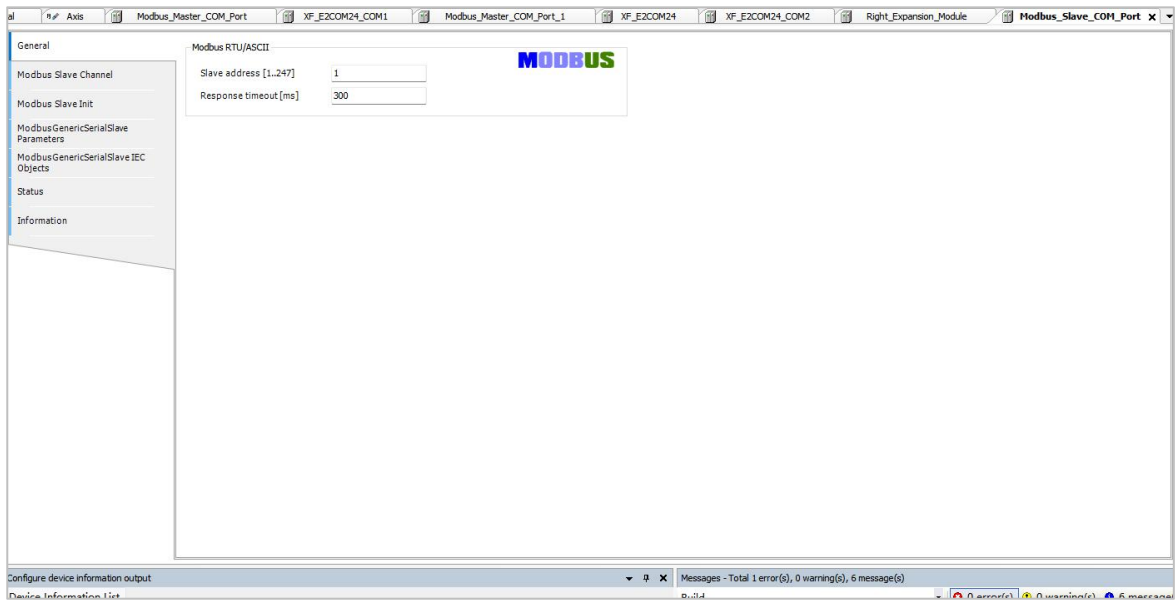

From station address	Set the slave station address (1 to 247).
Response timeout (ms)	Set the response timeout time for a slave station. If the slave station does not respond to the master station after this time, the master station will consider the slave station to have a communication failure.

Users can customize the Modbus communication channel for the slave device, provided it matches the actual hardware configuration. After clicking 'Add Channel,' the system will automatically display the 'Modbus Channel' dialog box, where users can directly configure access type, address offset, data length, and communication cycle time, as shown in the figure below.

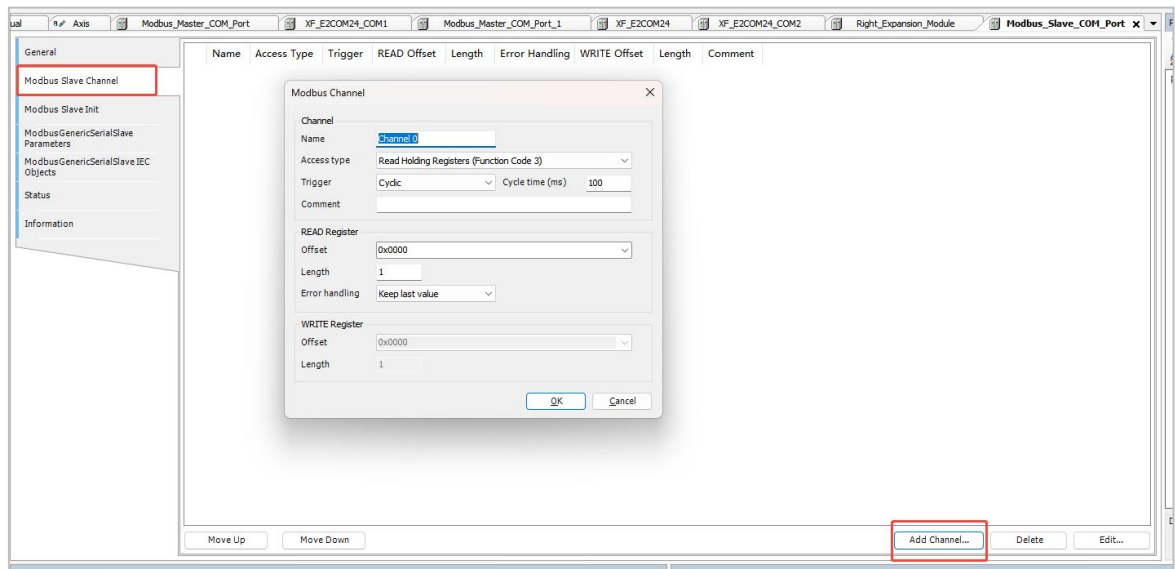

After completing the "Add Channel" configuration, the corresponding "IO Mapping" interface will automatically appear, displaying communication data and other relevant information. The "Always Update Variable" setting defaults to "Use Parent Device Settings". Users can configure the "Always Update Variable" according to their actual needs by selecting Enable 1 or Enable 2 from the dropdown menu. As shown in the figure below:

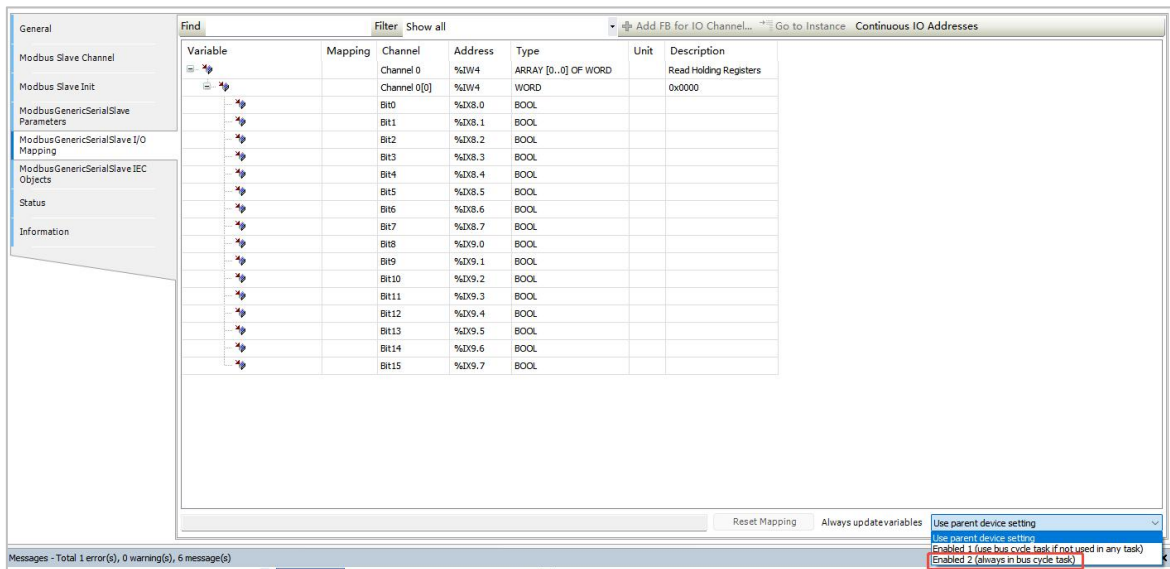

8.2.7.2 MODBUS Slave (XINJE)

Double-click "CPU Rack" to enter the hardware configuration interface. You can configure the protocol for the module's two serial channels by checking the checkbox in the window. Here, the first serial channel of the module is used for communication. Select "MODBUS Slave (XINJE)".

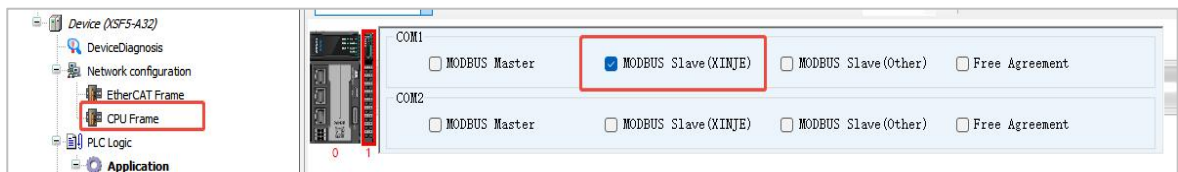

After adding a slave device, double-click the node "XF_E2COM24_COM1 (Modbus slave)" to open the configuration interface, which allows you to switch to the Modbus slave communication settings. See the figure below for details.

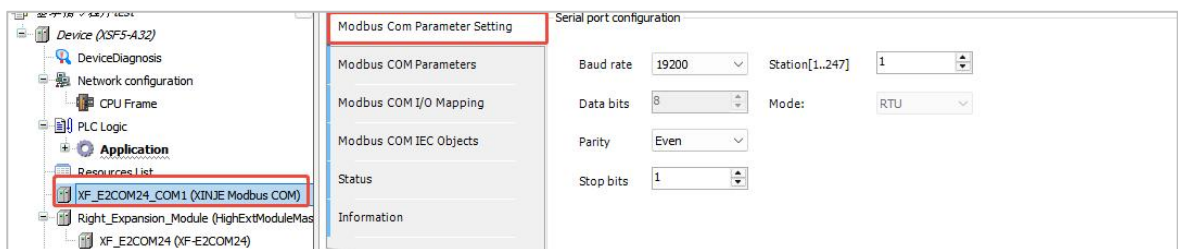

Baud rate	communication rate
data bit	bits in a communication frame
check bit	communication frame check method
stop bit	The last bit of a single packet in communication
stop number	This device station number ranges from 1 to 247.
pattern	MODBUS RTU

When configuring a Modbus RTU (XINJE) slave device, the address range accessible by the master device is defined as follows:

All coil operations (function codes 0x01,0x02,0x05,0x0F) have addresses for read/write

operations: %MB0-%MB65534.

All register operations (function codes 0x03,0x04,0x06,0x10) are accessible at addresses %MW40000-%MW105534.

8.2.7.3 MODBUS Slave (Other)

Double-click "CPU Rack" to enter the hardware configuration interface. Click the checkbox in the window to configure the protocol for the module's two serial channels. Here, the first serial channel of the module is used for communication. Select "MODBUS Slave (Other)".

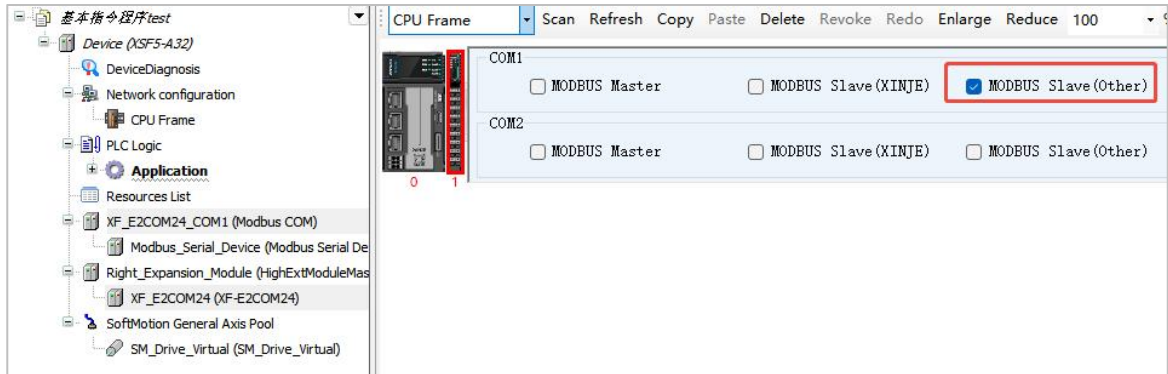

Double-click the XF_E2COM24_COM1 (Modbus COM) node to open the configuration interface, which allows switching to the Modbus slave communication configuration interface. See the figure below for details.

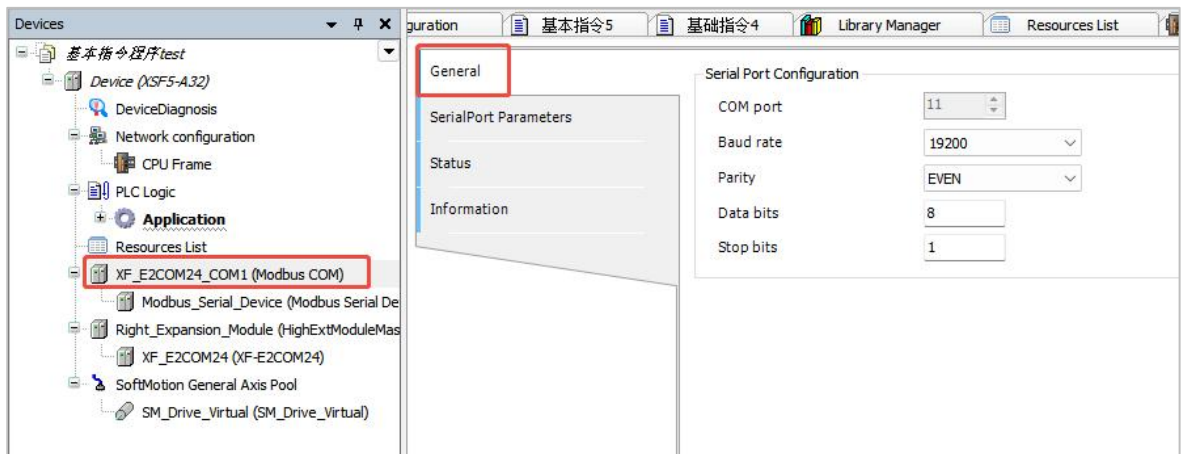

COM port	The right expansion port numbers start from 11 and cannot be modified. (Serial port numbers are arranged in the order they are added, and copied/pasted modules are also arranged in sequence. Dragging to delete a module with an assigned port number will not rearrange the port numbers.)
Baud rate	bits in a communication frame
even-odd check	communication frame check method
data bit	The last bit of a single packet in communication
stop bit	This device station number ranges from 1 to 247.

Click the "Modbus_Serial_Device" node in the left device tree to open the Modbus slave

communication data configuration interface, as shown in the figure below.

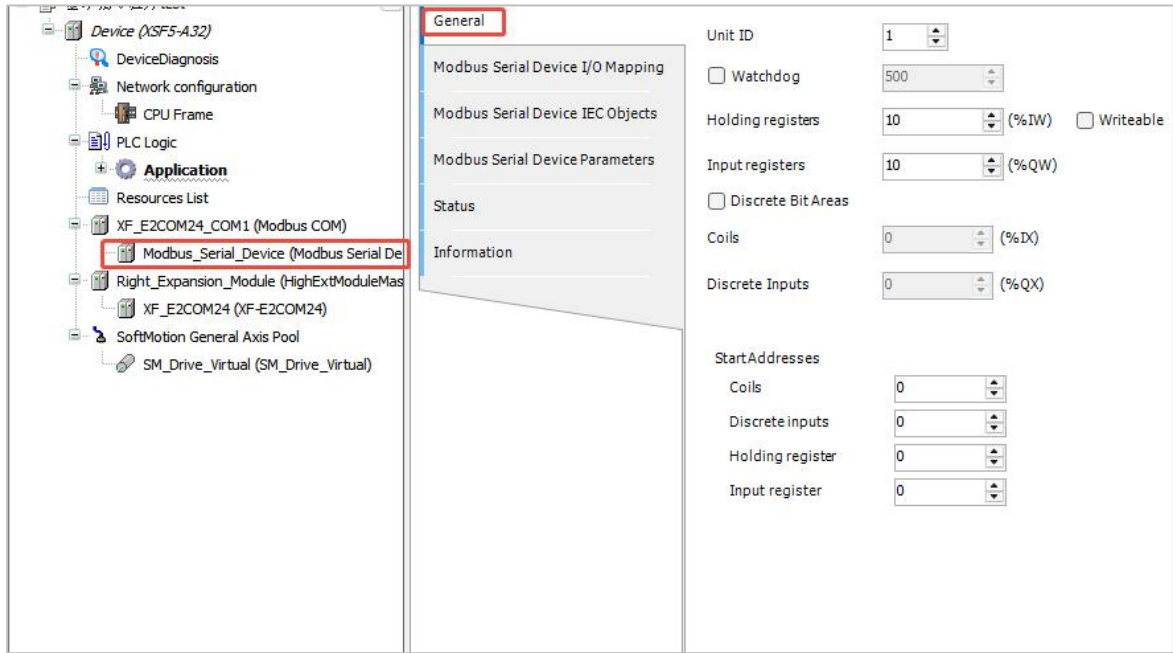

To switch to "Modbus Serial Device I/O Mapping" in this window, users must configure the "Bus Loop Options" and "Keep Variables Updated" according to their actual requirements, as shown in the figure below.

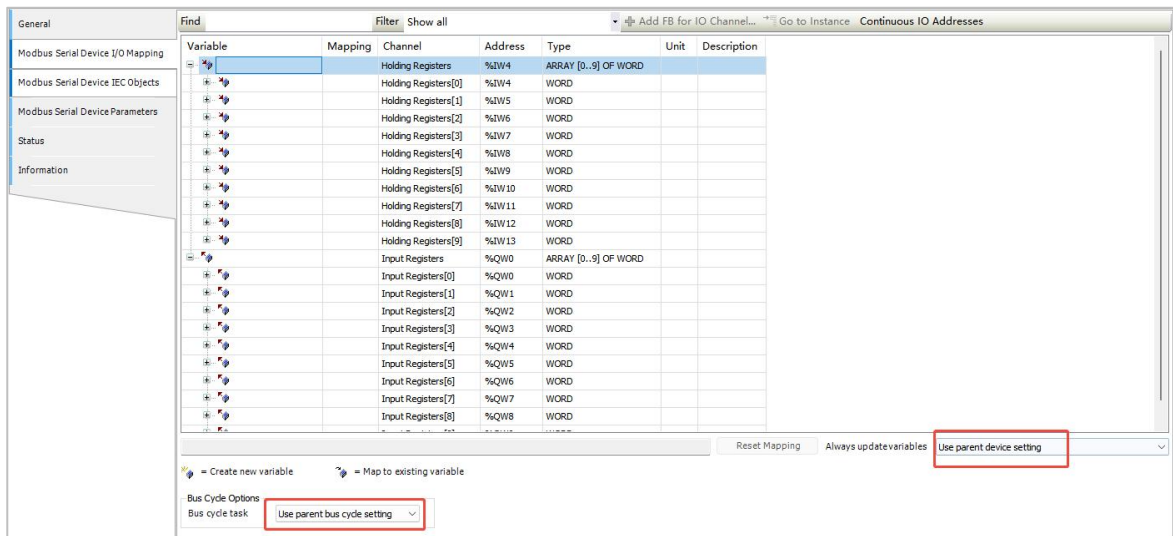

8.2.7.4 Free Format

The system provides two configuration methods: configuration interface and XJ_COMFree command library, with distinct data processing approaches.

Double-click "CPU Rack" to enter the hardware configuration interface. You can configure the protocol for the two serial ports of the module by clicking the checkbox in the window. Here, the first serial port of the module is used for communication. Select "Free Format".



9. Temperature module unit

9.1 Naming Rules

$\frac{\text{XF}}{\textcircled{1}} - \frac{\text{E}}{\textcircled{2}} \frac{\textcircled{3}}{\square} \frac{\square}{\textcircled{4}} \frac{\textcircled{5}}{\textcircled{3}} \frac{\square}{\textcircled{6}} - \frac{\textcircled{7}}{\textcircled{3}} - \frac{\square}{\textcircled{8}}$

①	Series name	XF: XF series expansion module
②	referential extension module	E: Right Extension Module
③	Input channel	4: 4 channel 8: 8 channel
④	Input type	RTD: hot resistance TC: thermocouple
⑤	outgoing channel	empty : no-output 4: 4 channel 8: 8 channel
⑥	Output type	empty : no-output Y: digital output DA: analog output
⑦	PID control function	empty : PID control is not supported P: PID control support
⑧	Module type	empty : conventional type H: channel spacing

9.2 Ordinary Resistance Temperature Detector Temperature Acquisition Unit XF-E4RTD

9.2.1 Product Overview

The XF-E4RTD series standard thermal resistance temperature acquisition expansion module features 4-channel thermal resistance temperature acquisition with DC24V power supply, compatible with XF/XSF series CPU units and XF series communication coupler units.

- 4-channel thermistor temperature acquisition;
- Compatible with three-wire and two-wire resistance temperature sensors.
- Supports the following sensor types: PT100, PT1000, CU50, CU100, NTC-5K, and NTC-10K.
- 0.1°C and 1°C resolution (optional);
- Conversion speed: 250ms/4CH, 500ms/4CH, or 1000ms/4CH (optional);
- 12mm width design.

■ Module Version

Hardware version	Firmware version	function
H2.0	V2.0	The basic functions are now officially operational for the first time.

9.2.2 Module View

1) Explanation of each part

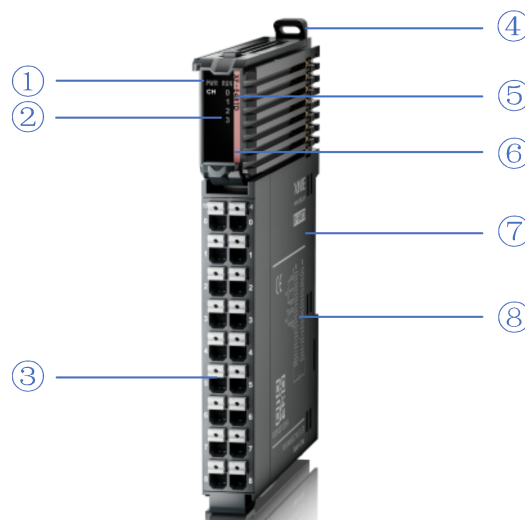

Number	name	Number	name
①	System LED indicator light	②	Channel LED indicator light
③	disconnectable terminal block	④	fastener
⑤	model indication	⑥	Color code for indicator module type

Number	name	Number	name
⑦	Module hardware and Firmware version	⑧	hookup

2) System Indicator Light

System Indicator Light	meaning	
PWR (green)	extinct	Module not powered on (backplane bus)
	Always on	All power supplies for the module are functioning normally (backplane bus power and external 24V input).
	Flash 1Hz*1	Partial module power supply is abnormal and cannot operate normally (external)
RUN (green)	Always on	The module is running normally
	Flash 1Hz*1	The module encountered a general error in the log
	extinct	The module encountered a critical error in the log
	10Hz*2	Modeling communication
	Dual Flash*3	firmware update



- *1: The duty cycle is 50%, and the frequency is 1Hz, with a square wave.
- *2: The duty cycle is 50%, and the frequency is 10Hz, with a square wave.
- *3: The hazard lights are shown below:

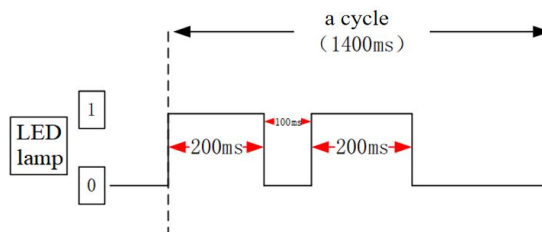

3) Channel indicator light light

model	Channel indicator light		
XF-E4RTD	CH0~CH3	Always on (green)	The channel is enabled and configured correctly
		Flash 1Hz	Sensor disconnected or channel-level error
		go out	forbidden channel

4) Color labels

Number	Color	Module type
1	hoar	digital input
2	gray	digital output & digital mixing module
3	wathet	read analogue input
4	mazarine	analog output
5	green	232&485 serial communication
6	rose hermosa	Temperature signal input
7	white	high speed counting
8	purple	pulse output
9	red	repeater power supply

9.2.3 General Specifications

project	specifications
Levels of protection	IP20
Anti-vibration	Complies with IEC61131-2 under intermittent vibration (frequency 5-9Hz, constant amplitude 3.5mm peak displacement) and (frequency 9-150Hz, constant acceleration 1.0g peak acceleration) The continuous shock vibration (5-9Hz, half amplitude 1.75mm displacement) and (9-150Hz, constant acceleration 0.5g, constant frame amplitude) Scan 10 times in X, Y, and Z directions
Shock resistance	Complies with IEC61131-2 standard Impact force of 15g (peak) was applied for 11ms to three mutually perpendicular axes, with 3 impacts per axis (total 18 impacts).
Operating altitude	0-2000 meters
Overvoltage class	II: Complies with IEC61131-2
Pollution level	2; Complies with IEC61131-2
Anti-interference EMC	Complies with IEC 61131-2 and IEC 61000-6-4 Type B
Relevant certifications	CE

9.2.4 Technical Specifications

project	specifications
Input channel count	4CH
Sensor type	PT100,PT1000,CU50,CU100,NTC-5K,NTC-10K
Temperature input range	See the sensor accuracy table for details.
conversion rate	250ms, 500ms, or 1000ms (default: 500ms)
resolution ratio	Select 1°C or 0.1°C (default: 0.1°C)
Module power supply	rated input: DC24V±10%, 6mA protect: reverse protection
accuracy	Room temperature: See the sensor accuracy table for details.

project		specifications
	25°C ± 5°C	
	Full temperature range: -20 to 55°C	See the sensor accuracy table for details.
insulate		Channel is not isolated, power is isolated
Module dissipation		0.7W (internal backplane) + 0.3W (external input)
Module weight		82g
maximum cable length		200 meters (only three-wire PT100, PT1000, CU50, and CU100 sensors; two-wire sensors cannot measure line resistance, and NTC sensors, due to their low accuracy, cannot ensure sampling precision over long distances)

Example of channel switching speed calculation:

If the sampling time is set to 250ms, each channel = 250ms/4 channels = 62.5ms.

When the channel is used, the sampling time = the number of channels 4*62.5ms =250ms/4 channels;

When the channel is disabled, for example, when 1 channel is disabled and 3 channels are enabled, the sampling time = 3*62.5ms=187.5ms; when 2 channels are disabled and 2 channels are enabled, the sampling time = 2*62.5ms=125ms.

9.2.5 Sensor Accuracy Table

type		Lower temperature limit	temperature upper limit	room temperature accuracy (25°C±5°C)	accuracy over the full temperature range (-20~55°C)
PT100		-200.0	850.0	±1°C	±2°C
PT1000		-200.0	850.0	±1°C	±2°C
CU50		-50.0	150.0	±1°C	±2°C
CU100		-50.0	150.0	±1°C	±2°C
NTC-5K	B value 2000~6000	Resistance: 40000Ω Calculate the temperature	Resistance: 400Ω Calculate the temperature	±1.5°C	±3°C
NTC-10K	B value 2000~6000	Resistance: 40000Ω Calculate the temperature	Resistance: 400Ω Calculate the temperature	±1.5°C	±3°C

The above precision indexes are all technical indexes in the unit of °C.

The NTC sensor has a resistance measurement range of 400Ω to 40,000Ω, a B value setting range of 2,000 to 6,000, and supports sensor labeling up to 5K.

For 10K and NTC sensors, the temperature measurement range is determined by the B value and sensor designation. The temperature calculation formula is as follows:

$$T = \frac{298.15 * B}{298.15 * \ln\left(\frac{R_L}{R_{25}}\right) + B} - 273.15 \text{ (Refer to the method specified in 4.9 of GB/T6663.1-2007)}$$

The resistance measured by RL ranges from 400 ohms to 40,000 ohms.

B is the B value, with a minimum of 2000 and a maximum of 6000.

R25 is the sensor model number, currently supporting 5K and 10K.

For example, using an NTC-5K sensor with a B value of 3000, the maximum resistance (RL) is 40,000 ohms and the minimum resistance is 400 ohms. The calculated temperature range is -26°C (rounded to the nearest integer) to 125°C (rounded to the nearest integer).

9.2.6 Installation & Wiring

9.2.6.1 Appearance dimensions

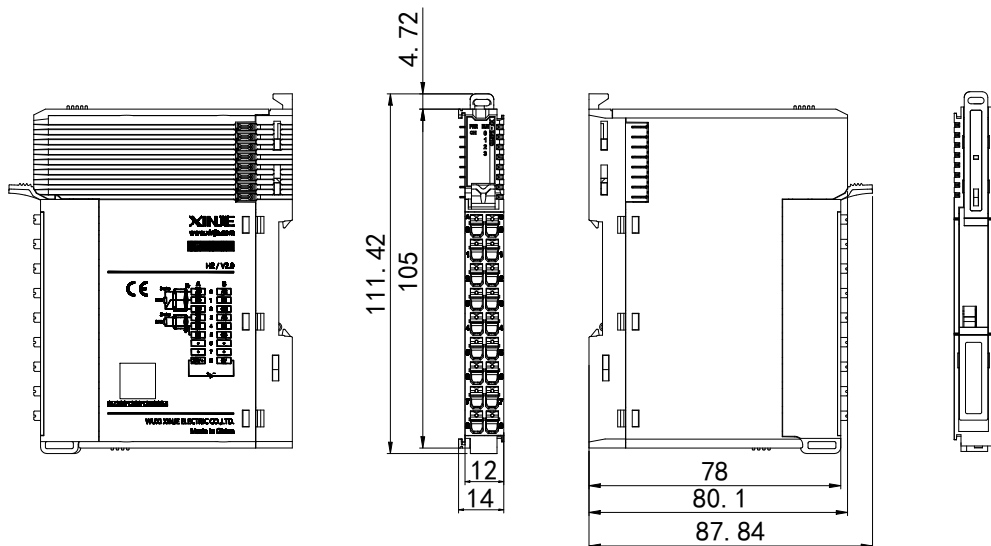

(unit :mm)

9.2.6.2 Terminal Definitions & Wiring

1) Terminal definition

XF-E4RTD						
meaning	terminal	A terminal	terminal arrangement	B terminal	terminal	meaning
CH0—Input	A0	0		0	A2	CH2—Input
CH0—Public	B0	1		1	B2	CH2—Public End
CH0—Public	C0	2		2	C2	CH2—Public End
CH1—Input	A1	3		3	A3	CH3—Input
CH1—Public	B1	4		4	B3	CH3—Public End
CH1—Public	C1	5		5	C3	CH3—Public End
empty	NC	6		6	NC	empty
empty	NC	7		7	NC	empty
external power supply to module 24V power supply positive	24V	8	8	0V	external power supply to module 24V power supply negative	

2) External wiring

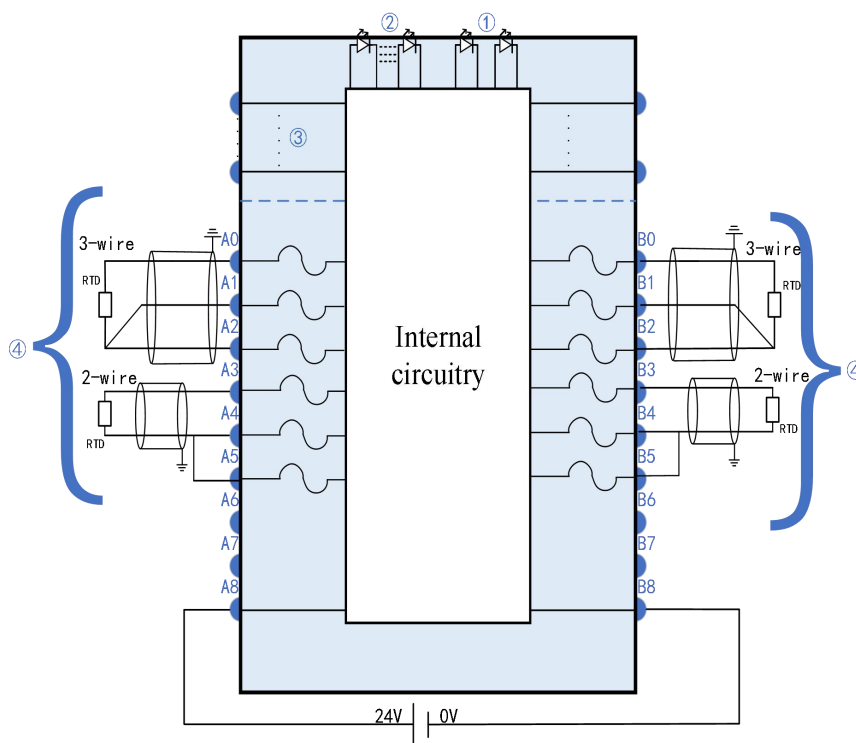

- ① System Indicator Light ② Channel indicator light ③ backplane bus ④ Input channel & wiring

9.2.6.3 Installation Method

1) Installation requirements

The module is mounted using DIN rails that comply with IEC 60715 standards (35mm wide, 1mm thick). The dimensions are shown in the figure below, with measurements in millimeters.

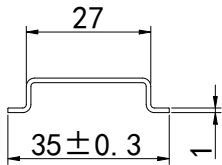

Attention

When the module is installed on a DIN rail not recommended above, the DIN rail latch may fail to lock properly.

2) Installation Steps

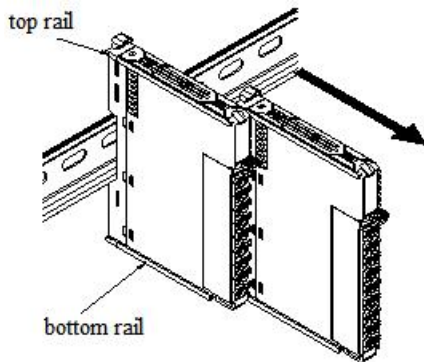

1. The IO modules are assembled by sliding along the top and bottom rails, as shown in the left figure.

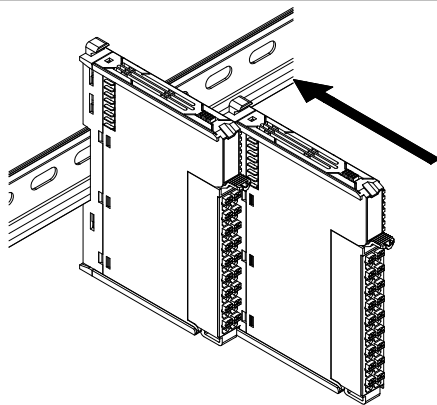

2. The module is mounted on the guide rail. During installation, align the module with the DIN guide rail and press it in the direction indicated by the arrow. A clear click sound will be heard when the module is properly secured, as shown in the left image.

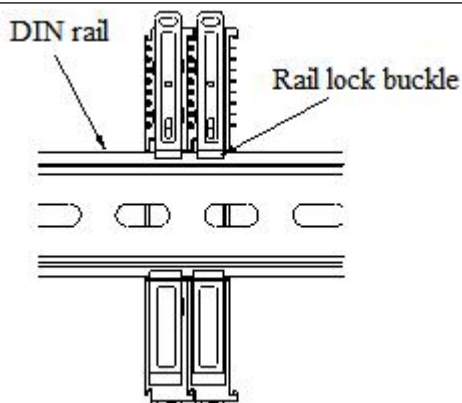

3. After module installation, the latch will automatically lower to lock. If it fails to move down, press the top of the latch downward to ensure proper installation.

3) Disassembly steps

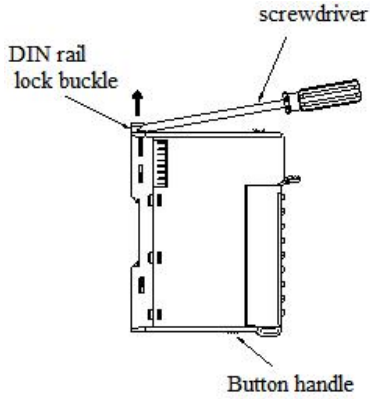

1. Use a screwdriver or similar tool to pry up the guide rail lock, as shown in the left image:

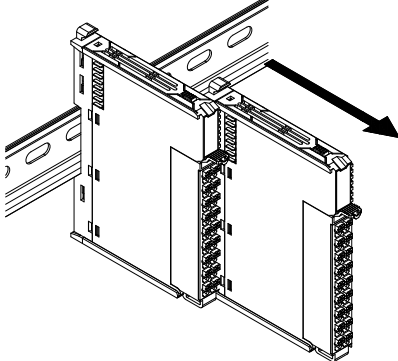

2. Pull the module straight forward from the buckle position (the raised part), then press down the top of the buckle as shown in the left image.

9.2.6.4 Installation Environment

This product supports four installation orientations: horizontal, vertical, top-mounted on electrical cabinets, and bottom-mounted. Horizontal installation is recommended. The cooling system utilizes natural convection. To ensure proper ventilation and heat dissipation while providing sufficient wiring space, a minimum clearance must be maintained around the product, as shown in the figure below.

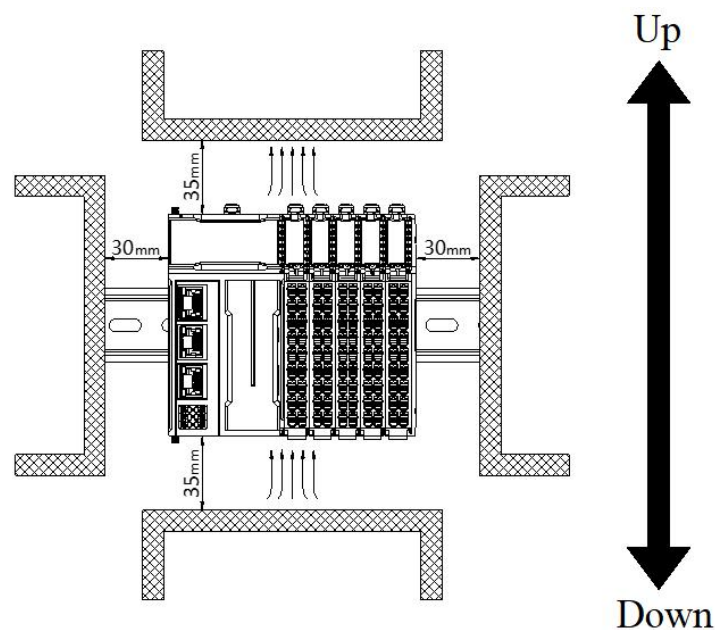



If the product is surrounded by high-temperature heat source equipment (heaters, transformers, large resistors, etc.), maintain a minimum gap of 100mm between the product and such equipment.

9.2.6.5 Equipment Wiring

When wiring the module, its connectors must meet the following requirements:

Suitable wire gauge	
National standard/mm ²	American-Standard /AWG
0.3	22
0.5	20
0.75	18
1.0	18
1.5	16

If using other wire-type terminal lugs, press them onto the stranded wire as shown in the figure below for shape and size requirements.

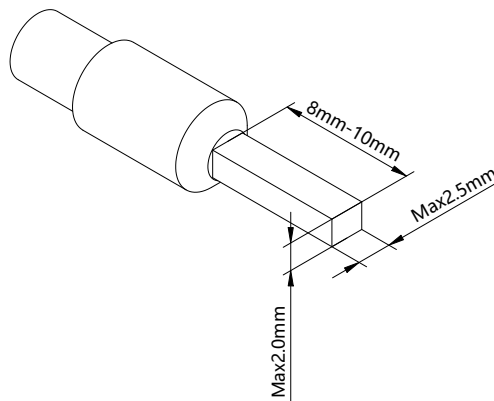

9.2.7 Configuration Module

To add the right expansion module: First, double-click the space in the 'CPU Architecture' section. Then, in the 'Insert Main Body Expansion Module' dialog box that appears, select 'XF_E4RTD' to add the module, as shown in the figure below.

Configuring LF Series Remote I/O: For detailed configuration examples, refer to the LF Series Remote I/O User Manual.

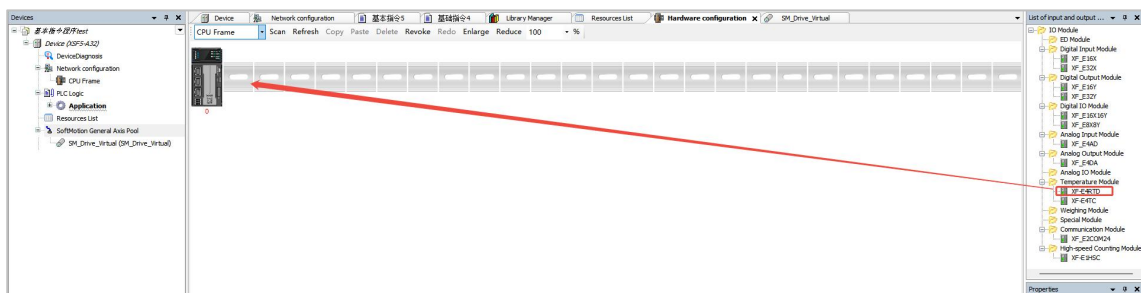

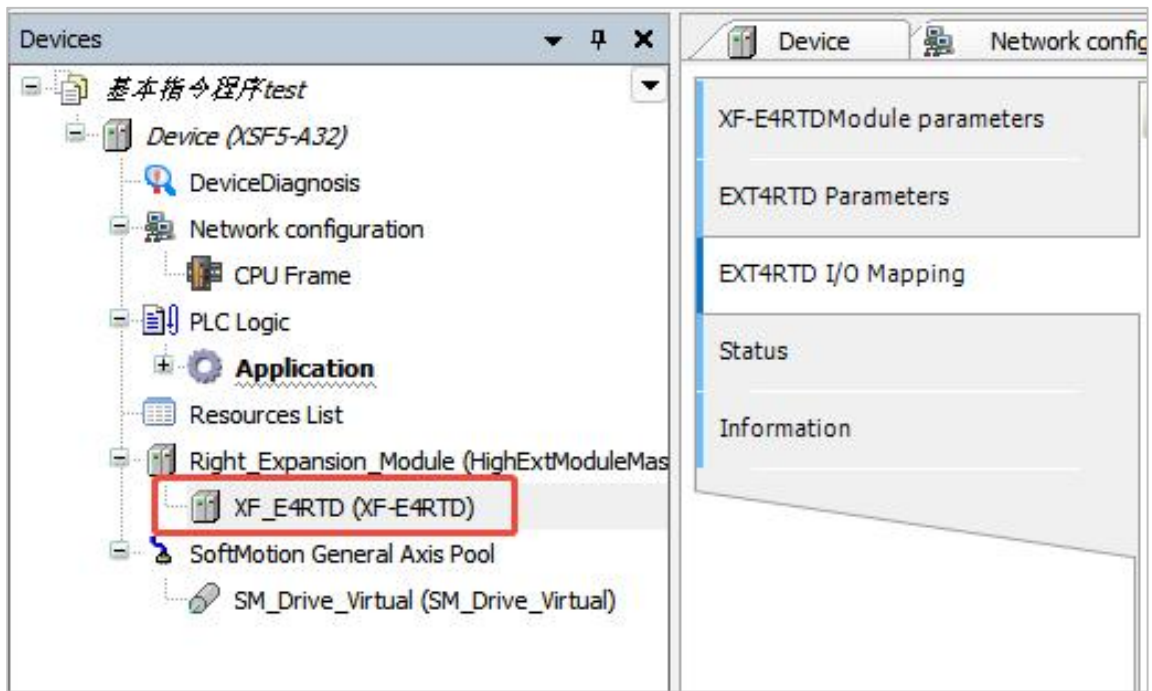

9.2.8 Module Parameters

The screenshot below is from XS Studio V2.3.0.

9.2.8.1 Regular Settings

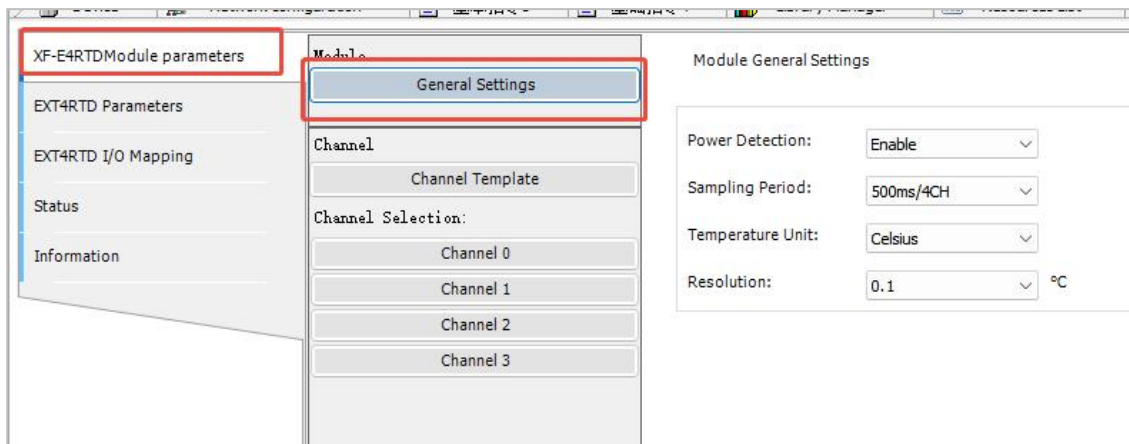

parameter	initial value	Explanation
Power supply detection	start using	Disable/Enable
sampling period	500ms/4CH	250ms/4CH
		500ms/4CH
		1000ms/4CH
degree-day	degree Celsius °C	Degrees Celsius (°C) / Degrees Fahrenheit (°F)
resolution ratio	0.1°C	1°C/1°F
		0.1°C/0.1°F

9.2.8.2 Channel Templates

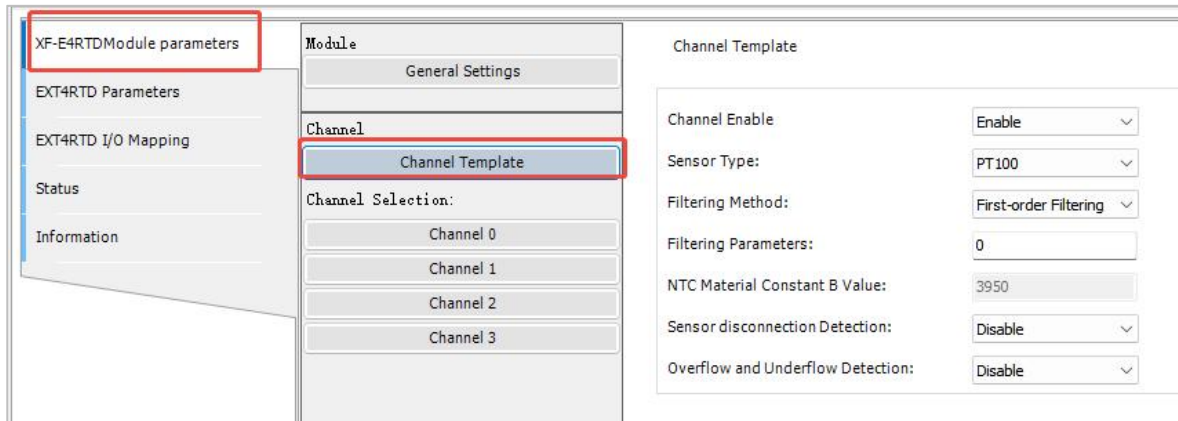

parameter	initial value	Explanation
channel enable	start using	Disable/Enable
Sensor type	PT100	PT100/PT1000/CU50/CU100/NTC-5K/NTC-10K
filtering mode	first order filter	First-order filter / time average / frequency average / moving average
filter parameter	0	The first-order filter (0~254) defaults to 0 Time average (250~60000ms) default value 1000 Average count (4~500) defaults to 4 Moving average (2~500) default 2
The value of the constant B in NTC materials	3950	2000~6000 Enter when the sensor type is NTC-5K or NTC-10K
Sensor line break detection	forbidden	Disable/Enable
overflow and underflow detection	forbidden	Disable/Enable

channel filter parameter		
first order filtering	Function actions	The first-order low-pass filter method combines the current sampling value with the previous filtered output value to produce a filtered result. The filter coefficient, adjustable by the user between 0 and 254, ensures data stability when set lower but may cause delays. Specifically, a coefficient of 1 provides optimal filtering and stability, while 254 delivers the weakest filtering effect. A value of 0 enables no filtering.
	Set range	0~254 (default value 0)
time average	Function actions	Convert A/D according to the set time, and average the total value after removing the maximum and minimum values. The averaged value is stored in the corresponding output buffer. The number of processing times within the set time varies according to the number of channels allowed for A/D conversion. The higher the value, the stronger the filtering effect.
	Set range	250 to 60,000 ms (default: 1,000)
number	Function	Convert A/D according to the set number of times, and average the total

channel filter parameter		
of times average	actions	value after removing the maximum and minimum values. The averaged value is stored in the corresponding channel variable. The time for storing the average of the averaged values in the corresponding channel variable varies depending on the number of channels allowed for A/D conversion. The higher the value, the stronger the filtering effect.
	Set range	4 to 500 (default 4)
shift Average per	Function actions	The specified number of digital output values obtained in each sampling cycle are averaged and stored in the corresponding output register/variable. Since moving average processing is performed in each sampling, the latest digital output value can be obtained. The higher the value, the stronger the filtering effect.
	Set range	2 to 500 (default: 2)



Calculate the number of measurement inputs to average using the "time average" option based on the following formula.

$$\text{Average number of measured input values processed} = \text{Average time} \div \text{Sampling period}$$

Discard the decimal values in the result. If the calculated value is less than or equal to 1, no filtering is applied.

9.2.8.3 Channel Selection

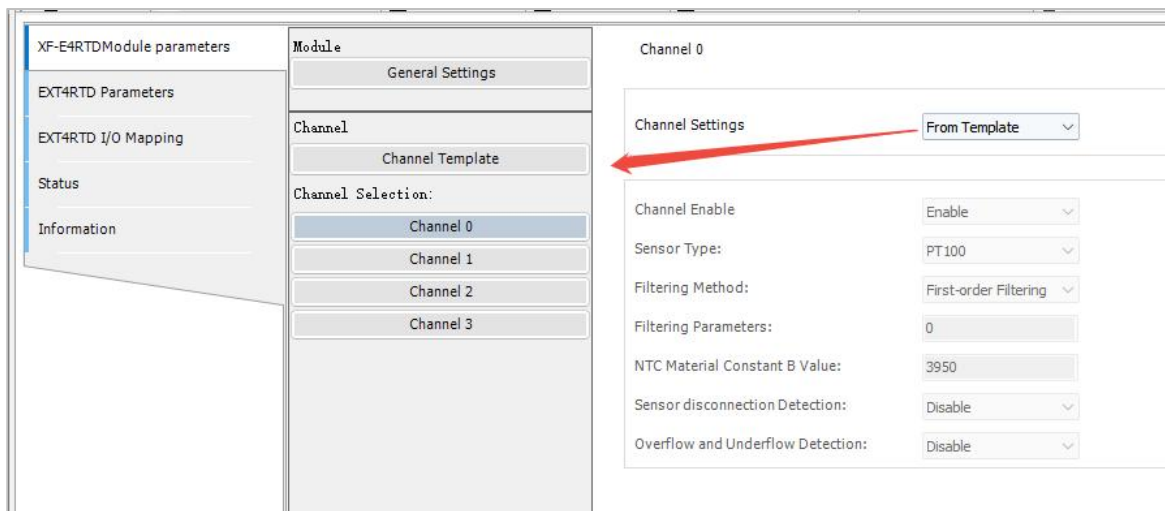

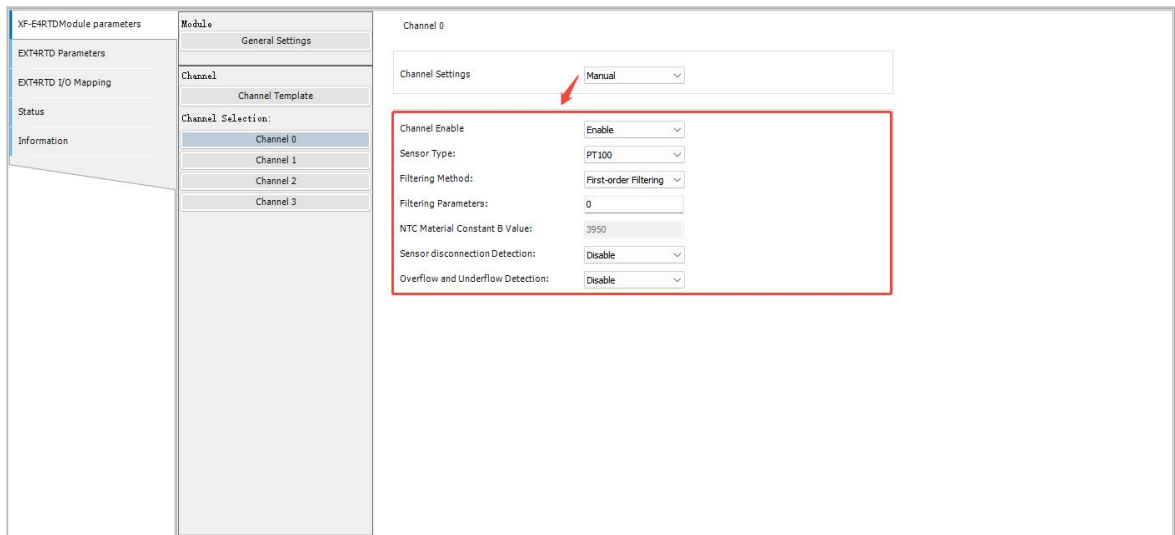

You can set parameters such as enabling, sensor type, and filtering mode for each channel individually.

Channel Settings	<p>From template: Use the configuration parameters in the "Channel Template" interface</p> <p>Manual: Use the configuration parameters at the bottom of this interface</p>
------------------	--

9.2.9 I/O Mapping

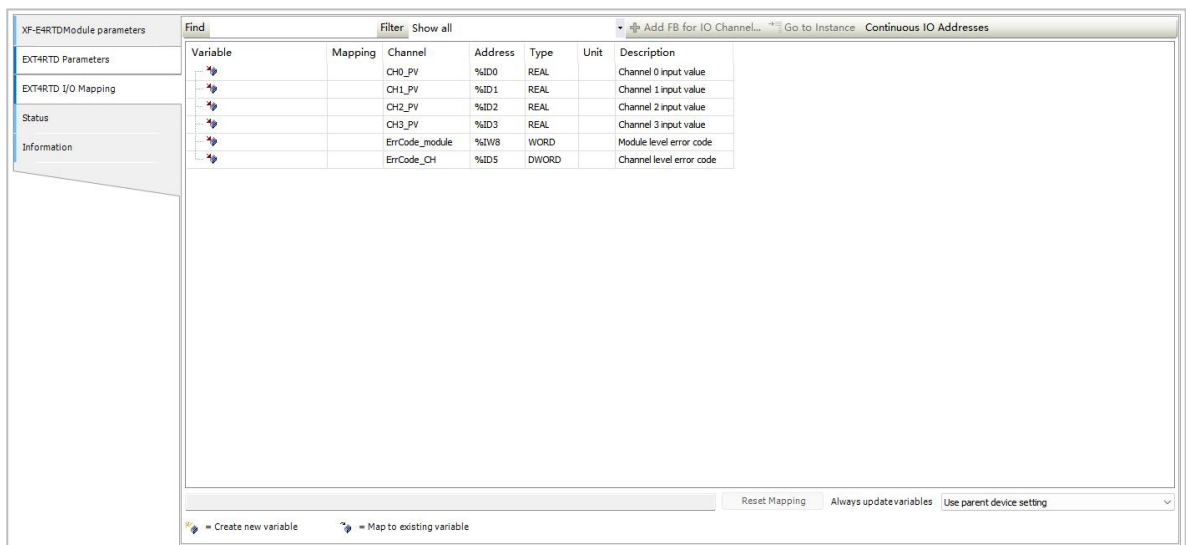

channel input value	Displays the temperature values of the four channels. See the temperature units and resolution in "Module Parameters" - "General Settings".
Module-level error code	See the table below
Channel level error code	See the table below

Module-level error code (ErrCode_module)		
Bit position	meaning	Error level

Module-level error code (ErrCode_module)		
Bit position	meaning	Error level
0	The 24V input power of the module is abnormal.	Critical
2	An internal module error occurred and the user layer cannot fix it	Critical
3	Version mismatch	Critical
4	ADC read/write failed	Critical

Channel level error code (EErrCode_CH)		
Bit position	meaning	Error level
0	channel 0 overflow	Medium
1	channel 0 overflow	Medium
2	Channel 0 disconnected	Medium
3	obligate	-
4	channel 1 overflow	Medium
5	channel 1 lower limit overflow	Medium
6	Channel 1 disconnected	Medium
7	obligate	-
8	channel 2 overflow	Medium
9	channel 2 lower limit overflow	Medium
10	Channel 2 is disconnected	Medium
11	obligate	-
12	channel 3 overflow	Medium
13	channel 3 lower limit overflow	Medium
14	Channel 3 is disconnected	Medium
15	obligate	-

9.3 Ordinary thermocouple temperature acquisition unit XF-E4TC

9.3.1 Product Overview

The XF-E4TC series standard thermocouple temperature acquisition expansion module features 4-channel thermocouple temperature acquisition, designed for pure acquisition scenarios without output channels. Powered by DC24V, it is compatible with XSF series CPU units and XF series communication coupler units.

- 4-channel thermocouple temperature acquisition;
- Supports K, S, E, N, B, T, J, and R sensor types.
- Supports voltage acquisition from -100mV to 100mV.
- 0.1°C and 1°C resolution (optional);
- Conversion speed: 250ms/4CH, 500ms/4CH, or 1000ms/4CH (optional);
- 12mm width design.

■ Module Version

Hardware version	Firmware version	function
H2.0	V2.0	The basic functions are now officially operational for the first time.

9.3.2 Module View

1) Explanation of each part

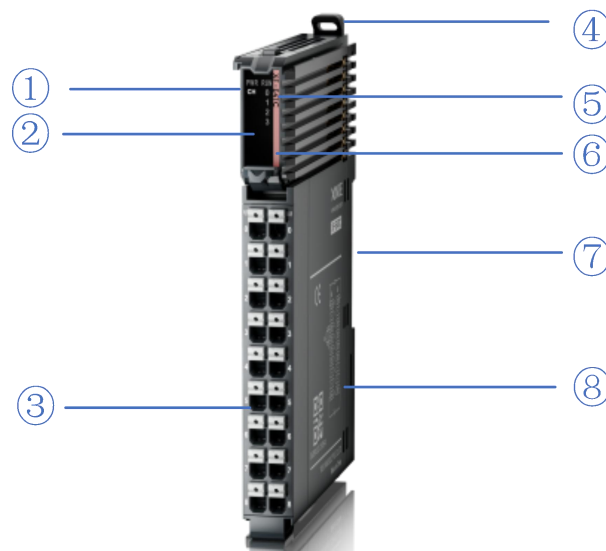

Number	name	Number	name
①	System LED indicator light	②	Channel LED indicator light
③	disconnectable terminal block	④	fastener

Number	name	Number	name
⑤	model indication	⑥	Color code for indicator module type
⑦	Module hardware and Firmware version	⑧	hookup

2) System Indicator Light

System Indicator Light	meaning	
PWR (green)	extinct	Module not powered (backplane bus)
	Always on	All power supplies for the module are functioning normally (backplane bus power and external 24V input).
	Flash 1Hz*1	Partial module power supply is abnormal and cannot operate normally (external)
RUN (green)	Always on	The module is running normally
	Flash 1Hz*1	The module encountered a general error in the log
	extinct	The module encountered a critical error in the log
	10Hz*2	Modeling communication
	Dual Flash*3	firmware update



- *1: The duty cycle is 50%, and the frequency is 1Hz, with a square wave.
- *2: The duty cycle is 50%, and the frequency is 10Hz, with a square wave.
- *3: The hazard lights are shown below:

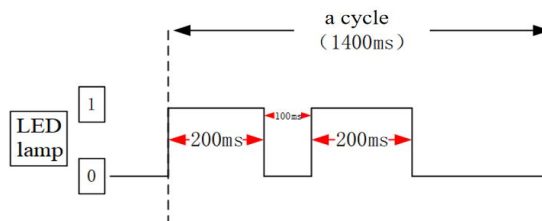

3) Channel indicator light light

model	Channel indicator light		
XF-E4TC	CH0~CH3	Always on (green)	The channel is enabled and configured correctly
		Flash 1Hz	Sensor disconnected or channel-level error
		go out	forbidden channel

4) Color labels

Number	Color	Module type
--------	-------	-------------

Number	Color	Module type
1	hoar	digital input
2	gray	digital output & digital mixing module
3	wathet	read analogue input
4	mazarine	analog output
5	green	232&485 serial communication
6	rose hermosa	Temperature signal input
7	white	high speed counting
8	purple	pulse output
9	red	repeater power supply

9.3.3 General Specifications

project	specifications
Levels of protection	IP20
Anti-vibration	Complies with IEC61131-2 under intermittent vibration (frequency 5-9Hz, constant amplitude 3.5mm peak displacement) and (frequency 9-150Hz, constant acceleration 1.0g peak acceleration) The continuous shock vibration (5-9Hz, half amplitude 1.75mm displacement) and (9-150Hz, constant acceleration 0.5g, constant frame amplitude) Scan 10 times in each of the X, Y, and Z directions
Shock resistance	Complies with IEC61131-2 standard Impact force of 15g (peak) was applied for 11ms to three mutually perpendicular axes, with 3 impacts per axis (total 18 impacts).
Operating altitude	0-2000 meters
Operating environment	Non-corrosive gas
Overvoltage class	II: Complies with IEC61131-2
Pollution level	2; Complies with IEC61131-2
Anti-interference EMC	Complies with IEC 61131-2 and IEC 61000-6-4 Type B
Related certifications	CE

9.3.4 Technical Specifications

project	specifications						
Input channel count	4CH						
Sensor type	thermocouple: K, S, E, N, B, T, J, R Voltage: -100mV to 100mV						
Analog input range (rated)	thermocouple <table border="1"> <tbody> <tr> <td>K mould</td> <td>-200.0°C~1300.0°C</td> </tr> <tr> <td>S mould</td> <td>-50.0°C~1768.0°C</td> </tr> <tr> <td>E mould</td> <td>-200.0°C~1000.0°C</td> </tr> </tbody> </table>	K mould	-200.0°C~1300.0°C	S mould	-50.0°C~1768.0°C	E mould	-200.0°C~1000.0°C
K mould	-200.0°C~1300.0°C						
S mould	-50.0°C~1768.0°C						
E mould	-200.0°C~1000.0°C						

project		specifications	
	N mould	-200.0°C~1300.0°C	
	B mould	250.0°C~1820.0°C	
	T mould	-200.0°C~400.0°C	
	J mould	-210.0°C~1200.0°C	
	R mould	-50.0°C~1768.0°C	
	voltage	-100mV~100mV (-32000~32000)	
conversion rate		Select 250ms, 500ms, or 1000ms (default: 500ms)	
resolution ratio	thermocouple	Select 1°C or 0.1°C (default: 0.1°C)	
	voltage	1/64000	
Module power supply	rated input	DC24V±10%, 6 mA	
	protect	reverse protection	
accuracy	Room temperature: 25°C ± 5°C	See the sensor accuracy table for details.	
	Full temperature range: -20 to 55°C	See the sensor accuracy table for details.	
repeatability		±0.05%	
cold end compensation method		Built-in cold end sensor, external cold end compensation, and fixed value compensation	
cold end compensation accuracy		See the cold-end accuracy table for details.	
insulate		Channel is not isolated, power is isolated	
Module dissipation		0.7W (internal backplane) + 0.3W (external input)	
Module weight		82g	
maximum cable length		50m	

Example of channel switching speed calculation:

If the sampling time is set to 250ms, each channel = 250ms/4 channels = 62.5ms.

When the channel is used, the sampling time = the number of channels 4*62.5ms =250ms/4 channels;

When the channel is disabled, for example, when 1 channel is disabled and 3 channels are enabled, the sampling time = 3*62.5ms=187.5ms; when 2 channels are disabled and 2 channels are enabled, the sampling time = 2*62.5ms=125ms.



-When the external compensation channel is selected for cold-end compensation, the module's sampling time will be extended by one channel's duration.
-If the sampling time is set to 250ms, the channel is not disabled, and the "cold end compensation mode" is selected as "external compensation channel", the actual sampling time of the module is 250+250/4=312.5ms.

9.3.5 Sensor Accuracy Table

■ accuracy standard

type	lower limit temperature	ceiling temperature	room temperature accuracy (25°C±5°C)	accuracy over the full temperature range (-20~55°C)
K mould	-200.0°C	1300.0°C	±1.5°C	±3°C
S mould	-50.0°C	1768.0°C	±2°C	±4°C
E mould	-200.0°C	1000.0°C	±1°C	±2°C
N mould	-200.0°C	1300.0°C	±1.5°C	±3°C
B mould	250.0°C	799.9°C	±4°C	±5°C
	800.0°C	1820.0°C	±2°C	±4°C
T mould	-200.0°C	400.0°C	±1°C	±2°C
J mould	-210.0°C	1200.0°C	±1°C	±2°C
R mould	-50.0°C	1768.0°C	±2°C	±4°C
-100mv/ +100mv	-32000 (digital quantity is only integer, decimal is 0)	32000 (digital quantity is only integer, decimal is 0)	±0.1%	±0.2%

■ Accuracy of built-in cold end compensation

Installation direction	adjacent module type	Accuracy of the built-in sensor for cold end compensation	
		T-type: above 90°C J, E, K, N above-100°C R, S above 200°C B above 400°C	T-type below 90°C J, E, K, and N below-100°C R, S below 200°C Type B does not guarantee accuracy below 400°C
Horizontal upright installation	temperature module	±1.5	±3.0
	non-temperature module	±4.0	±7.0
Non-horizontal upright installation	temperature module	±4.0	±7.0
	non-temperature module	±4.0	±7.0

The accuracy of the external cold end channel compensation is ±1.5°C.

Integrated Precision=Channel Conversion Precision+Cold End Compensation Precision



The above precision indexes are all technical indexes in the unit of °C.

9.3.6 Installation & Wiring

9.3.6.1 Appearance dimensions

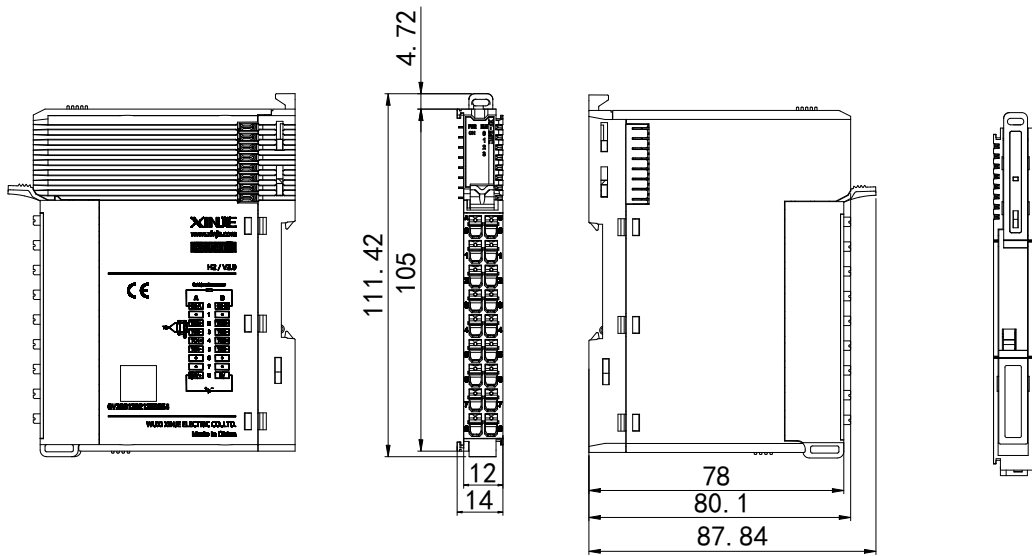

(unit :mm)

9.3.6.2 Terminal Definitions & Wiring

1) Terminal definition

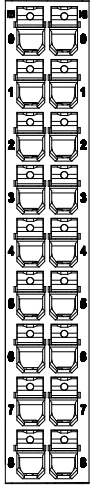
XF-E4TC						
meaning	terminal	A terminal	terminal arrangement	B terminal	terminal	meaning
cold end compensation	CJ-A	0		0	CJ-B	cold end compensation-B
empty	NC	1		1	NC	empty
CH0-Input	TC0+	2		2	TC2+	CH2 input
CH0-Public	TC0-	3		3	TC2-	CH2-Public
CH1-Input	TC1+	4		4	TC3+	CH3-Input
CH1-Public	TC1-	5		5	TC3-	CH3-Public
empty	NC	6		6	NC	empty
empty	NC	7		7	NC	empty
external power supply to module 24V power supply positive	24V	8		8	0V	external power supply to module 24V power supply negative

2) External wiring

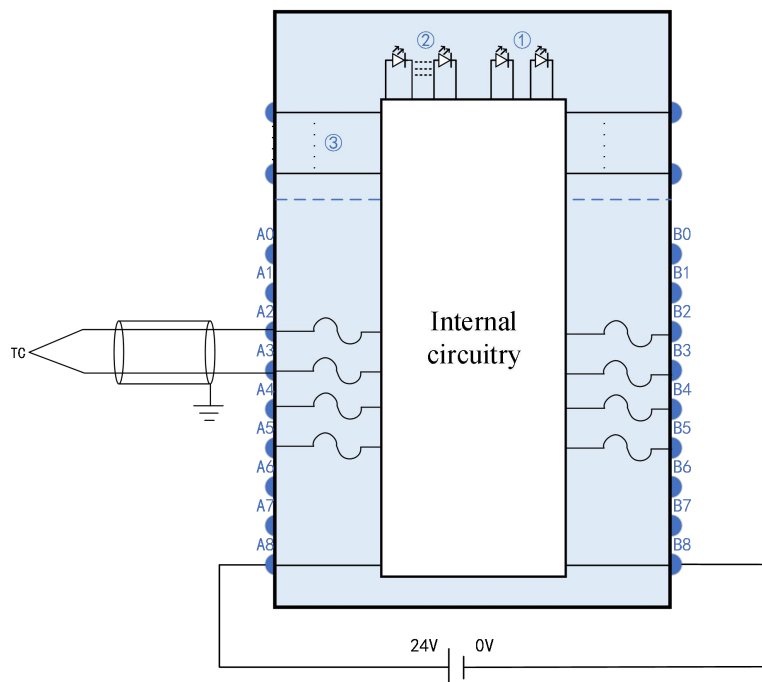

- ① System Indicator Light ② Channel indicator light ③ backplane bus ④ Input channel & wiring

9.3.6.3 Installation Method

1) Installation requirements

The module is mounted using DIN rails that comply with IEC 60715 standards (35mm wide, 1mm thick). The dimensions are shown in the figure below, with measurements in millimeters.

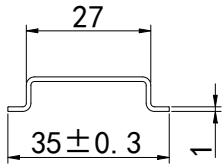

Attention

When the module is installed on a DIN rail not recommended above, the DIN rail latch may fail to lock properly.

2) Installation Steps

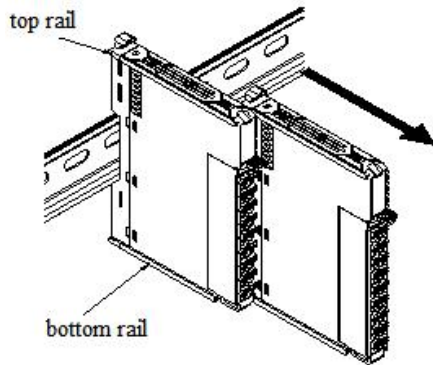

1. The IO modules are assembled by sliding along the top and bottom rails, as shown in the left figure.

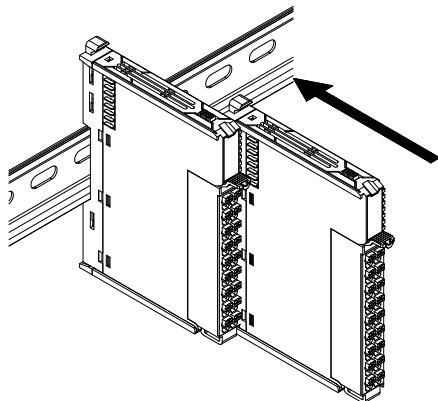

2. The module is mounted on the guide rail. During installation, align the module with the DIN guide rail and press it in the direction indicated by the arrow. A clear click sound will be heard when the module is properly secured, as shown in the left image.

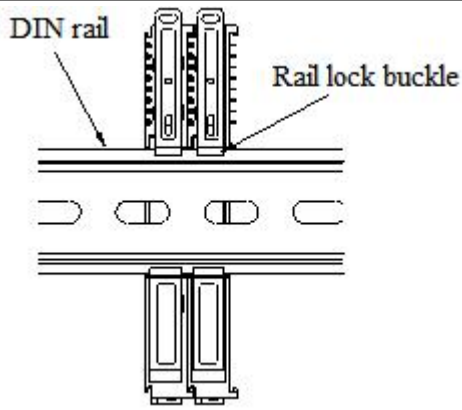

3. After module installation, the latch will automatically lower to lock. If it doesn't move down, press the top of the latch downward to ensure proper installation.

3) Disassembly steps

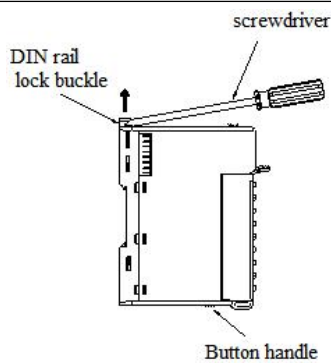

1. Use a screwdriver or similar tool to pry up the guide rail lock, as shown in the left image:

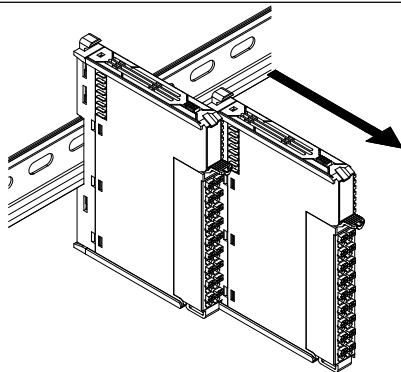

2. Pull the module straight forward from the buckle position (the raised part), then press down the top of the buckle as shown in the left image.

9.3.6.4 Installation Environment

This product supports four installation orientations: horizontal, vertical, top-mounted on electrical cabinets, and bottom-mounted. Horizontal installation is recommended. The cooling system utilizes natural convection. To ensure proper ventilation and heat dissipation while maintaining sufficient wiring clearance, a minimum clearance must be maintained around the product, as shown in the figure below.

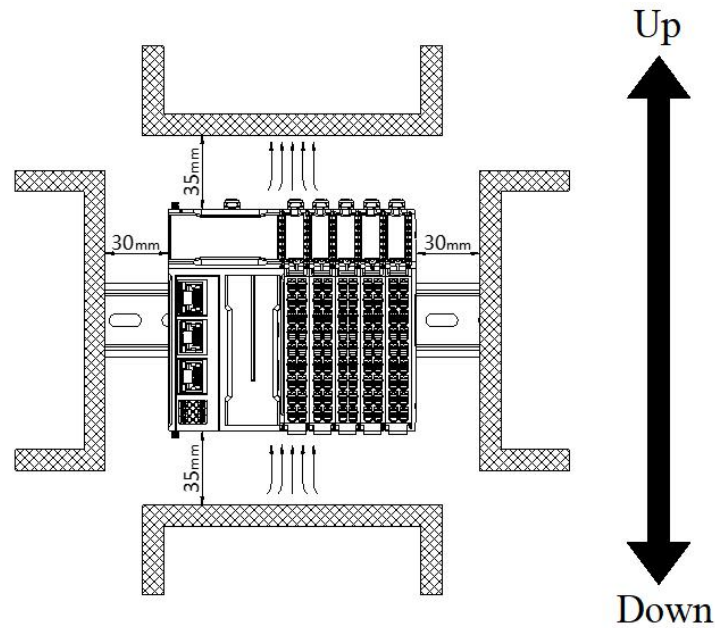

If the product is surrounded by high-temperature heat source equipment (heaters, transformers, high-resistance components, etc.), maintain a minimum clearance of 100mm between the product and such equipment.

9.3.6.5 Equipment Wiring

When wiring the module, the connectors must meet the following requirements:

Suitable wire gauge	
National standard/mm ²	American-Standard /AWG
0.3	22
0.5	20
0.75	18
1.0	18
1.5	16

If using other wire-type terminal lugs, press them onto the stranded wire as shown in the figure below for shape and size requirements.

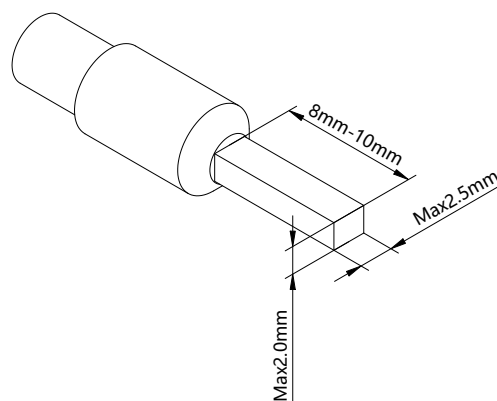

9.3.7 Configuration Module

To add the right expansion module: First, double-click the space in the 'CPU Architecture' section. Then, in the 'Insert Main Body Expansion Module' dialog box that appears, select 'XF_E4TC' to add the module, as shown in the figure below.

Configuring LF Series Remote I/O: For detailed configuration examples, refer to the LF Series Remote I/O User Manual.

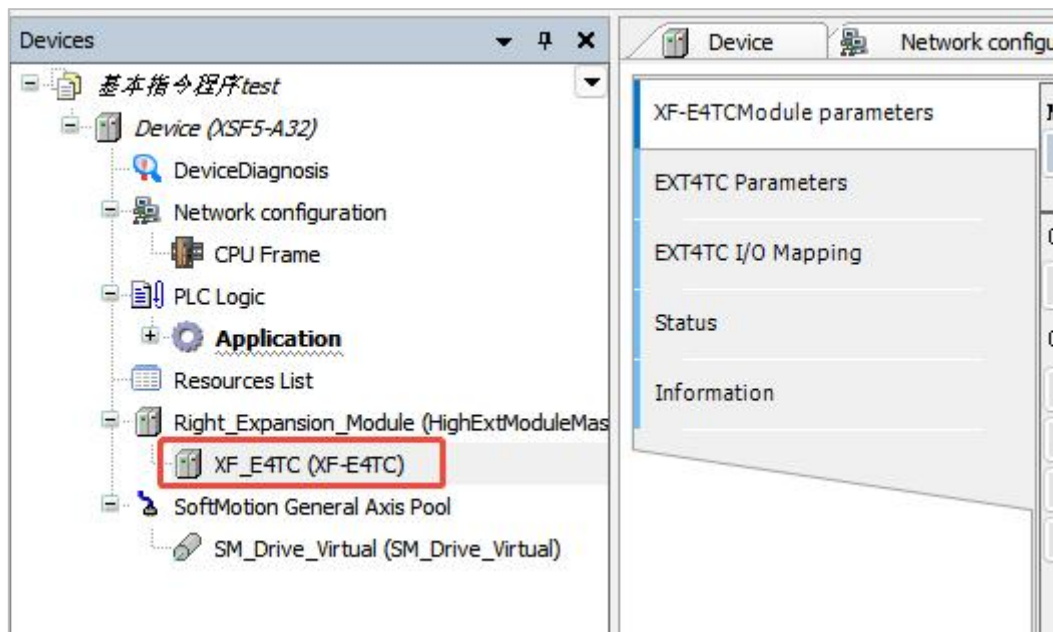
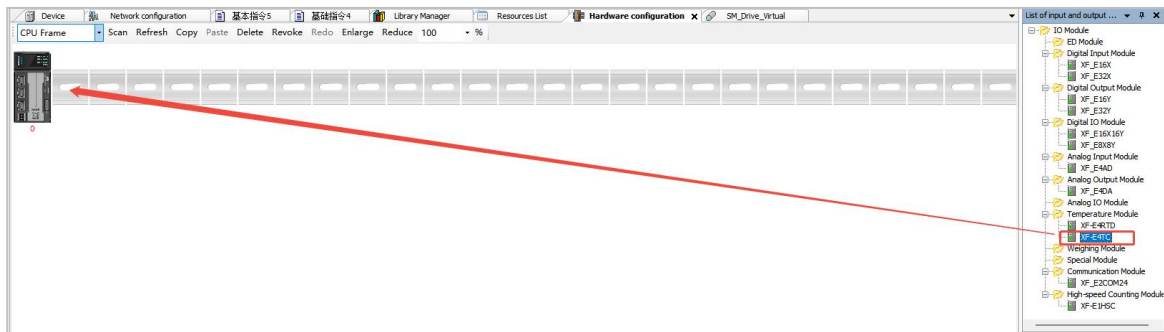

9.3.8 Module Parameters

The screenshot below is from XS Studio V2.3.0.

9.3.8.1 Regular Settings

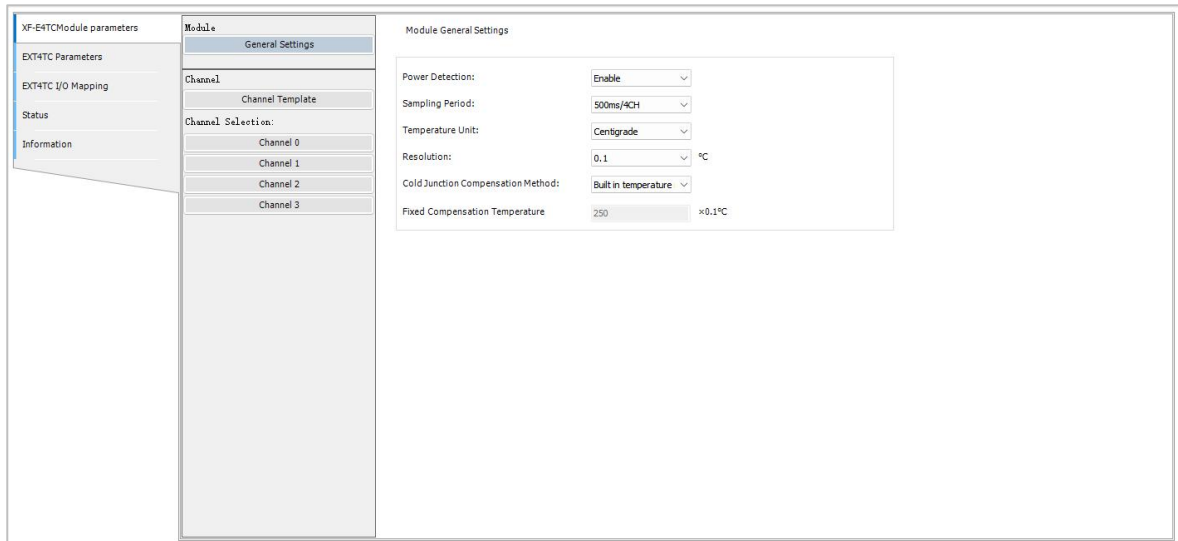

parameter	initial value	Explanation
Power supply detection	start using	Disable/Enable
sampling period	500ms/4CH	250ms/4CH 500ms/4CH 1000ms/4CH
degree-day	degree Celsius °C	degree Celsius °C Fahrenheit degree °F
resolution ratio	0.1°C	1°C/1°F 0.1°C/0.1°F
cold end compensation method	Built-in temperature sensor	Built-in temperature sensor external compensation channel fixed value compensation
Fixed value compensation temperature	250 (25.0°C)	Fixed value compensation temperature Unit: 0.1°C Range: -145.0°C to 155.0°C

■ Cold end compensation method & fixed value compensation temperature

A thermocouple consists of two wires made of different metals or metal alloys, with their ends welded together at a junction called the temperature measurement point. The other ends remain open, forming the reference junction (or cold junction). A thermoelectric voltage is generated at the measurement point between these wires, which depends on the temperature there. By measuring this voltage, the temperature can be determined. For accurate temperature measurement, the cold junction must remain constant to ensure the thermoelectric voltage remains proportional to the temperature. Any changes in the cold junction's ambient temperature during measurement can significantly affect accuracy. Therefore, temperature compensation is typically required for thermocouple temperature measurements.

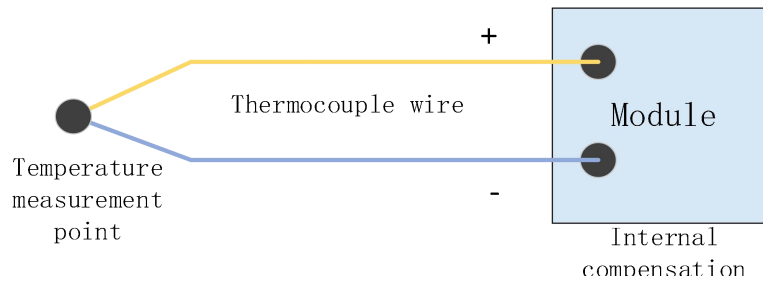

The module provides three cold end compensation methods: built-in temperature sensor, external compensation channel and fixed value compensation.

- The cold-end temperature is measured by the built-in cold-end sensor. The thermocouple must be directly connected to the module or connected via a compensation line.
- The external compensation channel requires an additional external thermistor (NTC5K, B3470) at the A0 and B0 terminals of the module to detect the cold junction temperature for compensation.

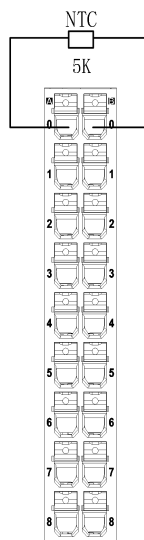

- The "Fixed Value Compensation" system applies a preset "Fixed Value Compensation Temperature" to the cold end, with a default value of 250 (25.0°C) and a range of -1450 to 1550 (0.1°C increments).

Note that this compensation temperature must match the actual temperature at the cold end's location. For enhanced precision, install the thermostat as shown in the diagram below and set the "Fixed Value Compensation Temperature" to the thermostat's internal temperature.

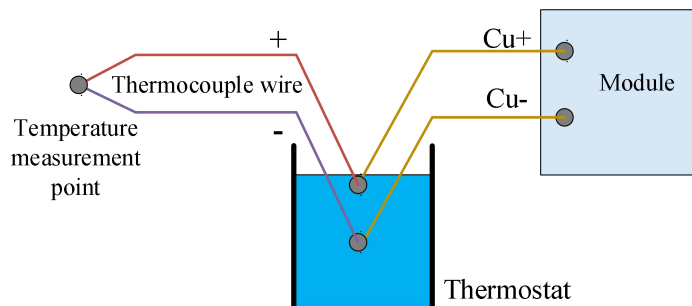

9.3.8.2 Channel Templates

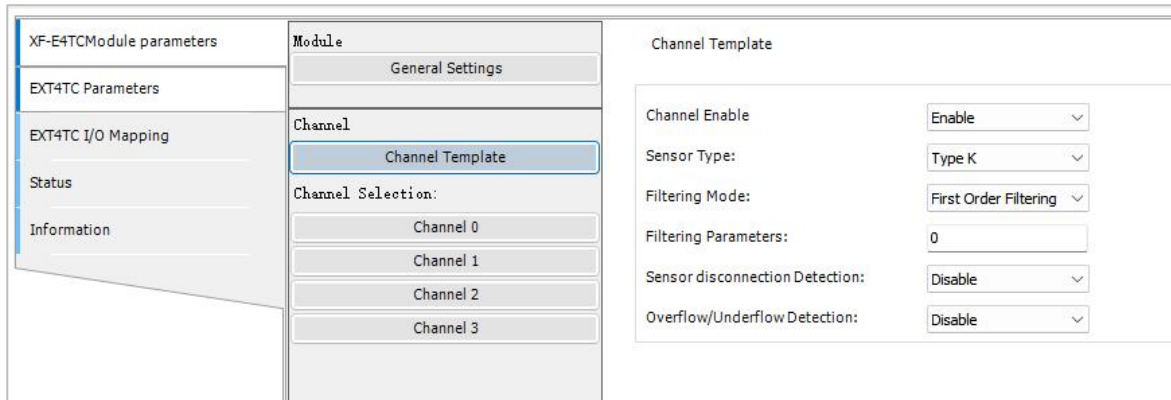

parameter	initial value	Explanation
channel enable	start using	Disable/Enable
Sensor type	K mould	thermocouple: K type, S type, E type, N type, B type, T type, J type, R type Voltage: -100mv/+100mv
filtering mode	first order filter	First-order filter / time average / frequency average / moving average
filter parameter	0	The first-order filter (0~254) defaults to 0 Time average (250~60000ms) default value 1000 Average count (4~500) defaults to 4 Moving average (2~500) default 2
Sensor line break detection	forbidden	Disable/Enable
overflow and underflow detection	forbidden	Disable/Enable

■ filter parameter

● first order filter

The first-order low-pass filter method combines the current sampling value with the previous filtered output value to produce a filtered result. The filter coefficient, adjustable by the user between 0 and 254, ensures data stability when set lower but may cause delays. Specifically, a coefficient of 1 provides optimal filtering performance with maximum stability, while 254 delivers the weakest filtering effect. A value of 0 enables no filtering.

● average filtering

parameter	Explanation
time average Function actions	Convert A/D according to the set time, and average the total value after removing the maximum and minimum values. The averaged value is stored in the corresponding output buffer. The number of processing times within the set time varies according to the number of channels allowed for A/D conversion.

parameter		Explanation
		The higher the value, the stronger the filtering effect.
	Set range	250 to 60,000 ms (default: 1,000)
number of times average	Function actions	Convert A/D according to the set number of times, and average the total value after removing the maximum and minimum values. The averaged value is stored in the corresponding channel variable. The time for storing the average of the averaged values in the corresponding channel variable varies depending on the number of channels allowed for A/D conversion. The higher the value, the stronger the filtering effect.
	Set range	4 to 500 (default 4)
shift Average per	Function actions	The specified number of digital output values obtained in each sampling cycle are averaged and stored in the corresponding output register/variable. Since moving average processing is performed in each sampling, the latest digital output value can be obtained. The higher the value, the stronger the filtering effect.
	Set range	2 to 500 (default: 2)



Calculate the number of measurement inputs to average using the "time average" option based on the following formula.

$$\text{Average number of measured input values processed} = \text{Average time} \div \text{Sampling period}$$

Discard the decimal values in the result. If the calculated value is less than or equal to 1, no filtering is applied.

■ overflow setting

The system logs an alarm and outputs the set value when the channel sampling exceeds the upper limit or falls below the lower limit of the sensor. If the sampling exceeds the upper limit, the system displays the upper limit value; if it falls below the lower limit, the system displays the lower limit value.

9.3.8.3 Channel Selection

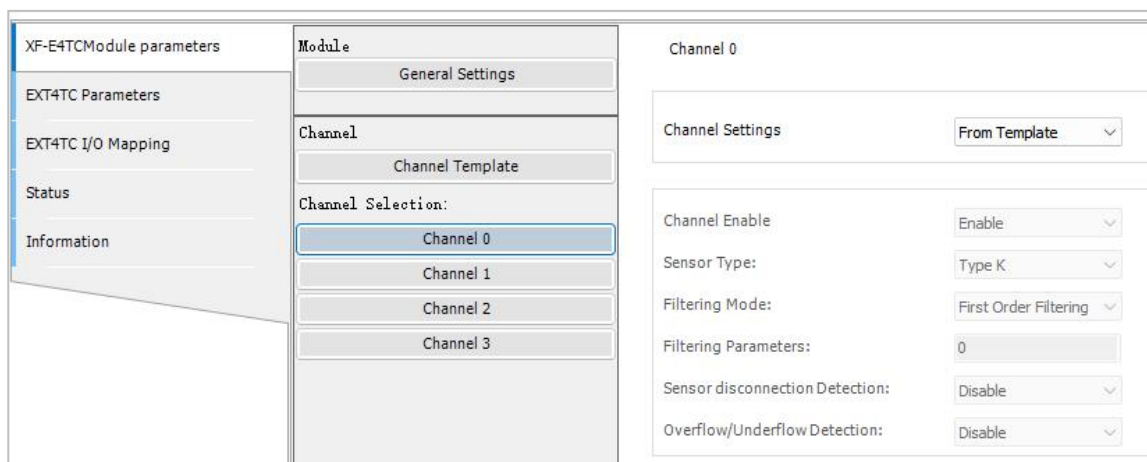

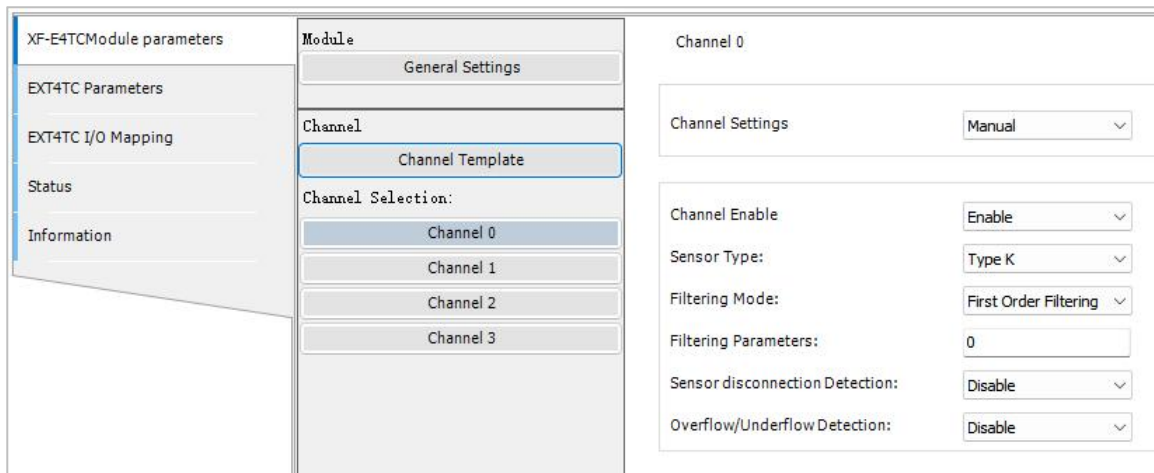

You can set parameters such as enabling, sensor type, and filtering mode for each channel individually.

Channel Settings	<p>From template: Use the configuration parameters in the "Channel Template" interface</p> <p>Manual: Use the configuration parameters at the bottom of this interface</p>
------------------	--

9.3.9 I/O Mapping

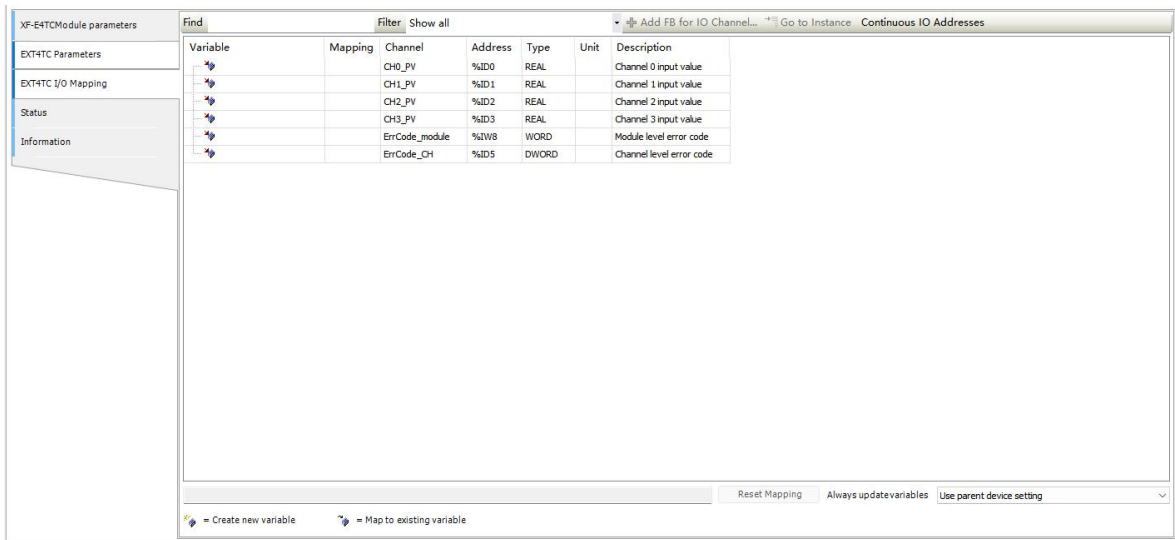

channel input value	Displays the temperature values of the four channels. See the temperature units and resolution in "Module Parameters" - "General Settings".
Module-level error code	See the table below
Channel level error code	See the table below

Module-level error code (ErrCode_module)		
Bit position	meaning	Error level
0	The 24V input power of the module is abnormal.	Critical
2	An internal module error occurred and the user layer cannot fix it	Critical
3	Version mismatch	Critical
4	ADC read/write failed	Critical

Module-level error code (ErrCode_module)		
Bit position	meaning	Error level
5	The cold-end sensor has a broken wire.	Critical

Channel level error code (EErrCode_CH)		
Bit position	meaning	Error level
0	channel 0 overflow	Medium
1	channel 0 overflow	Medium
2	Channel 0 disconnected	Medium
3	obligate	-
4	channel 1 overflow	Medium
5	channel 1 lower limit overflow	Medium
6	Channel 1 disconnected	Medium
7	obligate	-
8	channel 2 overflow	Medium
9	channel 2 lower limit overflow	Medium
10	Channel 2 is disconnected	Medium
11	obligate	-
12	channel 3 overflow	Medium
13	channel 3 lower limit overflow	Medium
14	Channel 3 is disconnected	Medium
15	obligate	-

10. High-speed counting module unit

10.1 Naming Rules

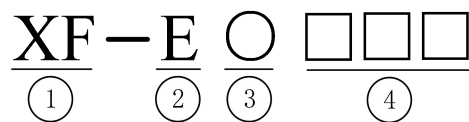

①	Series name	XF:	XF series expansion module
②	referential extension module	E:	Right Extension Module
③	Input channel	1:	1 channel
		2:	2 channel
		4:	4 channel
④	Output type	HSC:	high speed counting
		HSP:	pulse output

10.2 High-speed counting module unit XF-E1HSC

10.2.1 Product Overview

The XF-E1HSC high-speed counting expansion module operates on DC24V power supply, compatible with XF/XSF series CPU units and XF series communication coupler units.

- The module supports single-ended input (bipolar) or differential input (A/B/Z) for a single-channel encoder.
- The differential input supports up to 2MHz (1x frequency), while the single-ended input supports up to 200kHz (1x frequency).
- The channel mode supports single-phase, pulse+direction, A/B/Z phase, and CW/CCW mode selection.
- A/B phase supports 1/2/4 octave selection;
- The module supports frequency measurement.
- Support pulse width measurement function;
- Supports dual high-speed (high-response) inputs X0 and X1, with probe functionality.
- Supports 4 high-speed (high-response) outputs (Y0, Y1, Y2, Y3) and a comparison output (flop) function.
- 12mm width design.

■ Module Version

Hardware version	Firmware version	function
H2.0	V2.0	The basic functions are now officially operational for the first time.

10.2.2 Module View

1) Explanation of each part

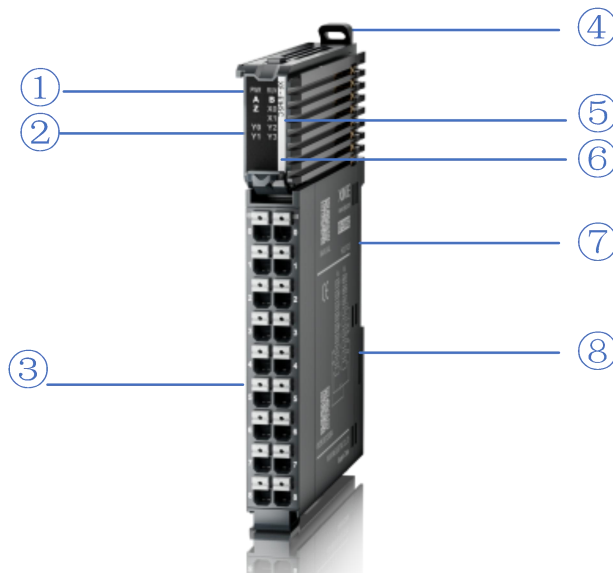

Number	name	Number	name
①	System LED indicator light	②	Channel LED indicator light
③	disconnectable terminal block	④	fastener
⑤	model indication	⑥	Color code for indicator module type
⑦	Module hardware and Firmware version	⑧	hookup

2) System Indicator Light

System Indicator Light	meaning	
PWR (green)	extinct	Module not powered (backplane bus)
	Always on	All power supplies for the module are functioning normally (backplane bus power and external 24V input).
	Flash 1Hz*1	Partial module power supply is abnormal and cannot operate normally (external)
RUN (green)	Always on	The module is running normally
	Flash 1Hz*1	The module encountered a general error in the log
	extinct	The module encountered a critical error in the log
	10Hz*2	Modeling communication
	Flash*3	Module heartbeat detection in progress
	Dual Flash*4	firmware update



- *1: The duty cycle is 50%, and the frequency is 1Hz, with a square wave.
- *2: The duty cycle is 50%, and the frequency is 10Hz, with a square wave.
- *3: Indicator light specification: ON:0.2s OFF:1.8s
- *4: The hazard lights are shown below:

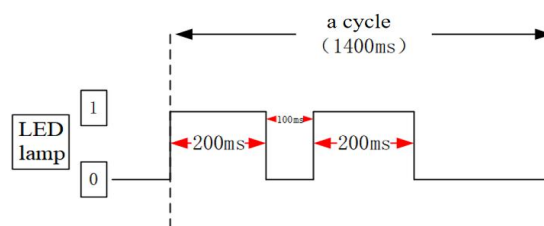

3) Channel indicator light light

model	Channel indicator light		
XF-E1HSC	A,B,Z	Always on (green)	The corresponding input channel has an ON signal
		go out	The corresponding input channel has no ON signal
	X0,X1	Always on (green)	The corresponding input channel has an ON signal.
		go out	The corresponding input channel has no ON signal
	Y0,Y1,Y2,Y3	Always on	The corresponding output channel has an ON signal

model	Channel indicator light	
	(green)	
	go out	The corresponding output channel has no ON signal

4) Color labels

Number	Color	Module type
1	hoar	digital input
2	gray	digital output & digital mixing module
3	wathet	read analogue input
4	mazarine	analog output
5	green	232&485 serial communication
6	rose hermosa	Temperature signal input
7	white	high speed counting
8	purple	pulse output
9	red	repeater power supply

10.2.3 General Specifications

project		specifications
Operation temperature	Maximum temperature	55°C
	Minimum temperature	-20°C
Transportation/Storage Temperature	Maximum temperature	70°C
	Minimum temperature	-40°C
Environmental humidity (including operation/storage)	superior limit	95%
	lower limit	10%
Levels of protection		IP20
Anti-vibration		Complies with IEC61131-2 under intermittent vibration (frequency 5-9Hz, constant amplitude 3.5mm peak displacement) and (frequency 9-150Hz, constant acceleration 1.0g peak acceleration) The continuous shock vibration (5-9Hz, half amplitude 1.75mm displacement) and (9-150Hz, constant acceleration 0.5g, constant frame amplitude) Scan 10 times in each of the X, Y, and Z directions
Shock resistance		Complies with IEC61131-2 standard Impact intensity of 15G (peak) was applied for 11ms on each of three mutually perpendicular axes, with 3 impacts per axis

project	specifications
	(total 18 impacts).
Operating environment	Non-corrosive gas
Operating altitude	0-2000 meters
Overvoltage class	II: Complies with IEC61131-2
Pollution level	2; Complies with IEC61131-2
Anti-interference EMC	Complies with IEC 61131-2 and IEC 61000-6-4 Type B
Related certifications	CE

10.2.4 Technical Specifications

project		specifications
input specification	counter	A,B,Z
	type	Supports single-ended or differential input
	high speed input channel number	Route 2 (X0 X1)
	Input type	NPN&PNP
	Rated input voltage	24VDC
	Rated input current	6mA
	ON voltage	15V
	ON Input current	2.5mA or more
	Enter the OFF voltage	5V
	Enter the OFF current	Below 1mA
Output specifications	Output type	NPN
	control loop voltage	DC24V(DC21.6~26.4V)
	rated load current	0.5A/1 point 1A/ module
	ON response time	1us
	OFF response time	1us
Output protection		Supports short-circuit and overload protection
Module dissipation		0.8W (internal backplane) + 1.2W (external input)

10.2.5 Installation & Wiring

10.2.5.1 Appearance dimensions

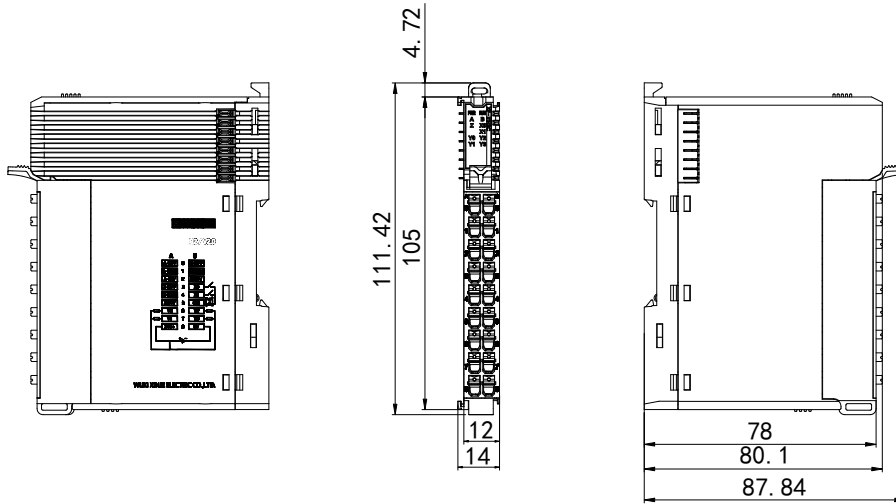

(unit :mm)

10.2.5.2 Terminal Definitions & Wiring

1) Terminal definition

XF-E1HSC				
meaning	A terminal	terminal arrangement	B terminal	meaning
A-DIFF	0		0	B-DIFF
A-COM	1		1	B-COM
A-24V	2		2	B-24V
Z-DIFF	3		3	X0
Z-COM	4		4	X1
Z-24V	5		5	S/S
Y0	6		6	Y2
Y1	7		7	Y3
24V+	8		8	24V-



- NPN: The S/S terminal is 24V, while the X terminal is 0V.
- PNP: The S/S terminal is 0V, while the X terminal is 24V.

2) External wiring

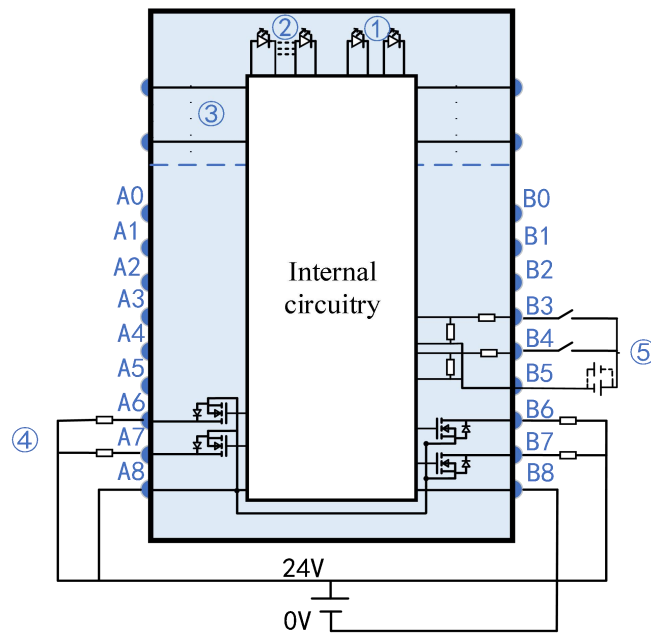

- ① System Indicator Light ② Channel indicator light ③ backplane bus ④ Output channel & wiring light
- ⑤ Input channel & wiring

The module supports a set of A, B, and Z high-speed single-ended differential signal inputs. Ensure proper wiring during operation. The following table illustrates an application example using A0 as a reference.

Input type	External wiring	No.	Signal name	Internal circuit
PNP collector type (24V level)		0	Differential input (A-DIFF)	
		1	Input common terminal (A-COM)	
		2	34V single end input (A-24V)	
NPN collector type (24V level)		0	Differential input (A-DIFF)	
		1	Input common terminal (A-COM)	
		2	34V single end input (A-24V)	
Differential signal		0	Differential input (A-DIFF)	
		1	Input common terminal (A-COM)	
		2	34V single end input (A-24V)	

Note: For PNP-type AB-phase encoders, short A-COM and B-COM; for NPN-type AB-phase encoders, short A-24V and B-24V.

10.2.5.3 Installation Method

1) Installation requirements

The module is mounted using DIN rails that comply with IEC 60715 standards (35mm wide, 1mm thick). The dimensions are shown in the figure below, with measurements in millimeters.

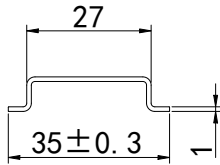

Attention

When the module is installed on a DIN rail not recommended above, the DIN rail latch may fail to lock properly.

2) Installation Steps

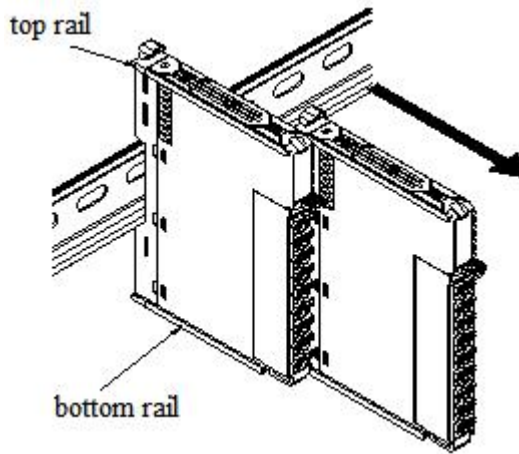

1. The IO modules are assembled by sliding along the top and bottom rails, as shown in the left figure.

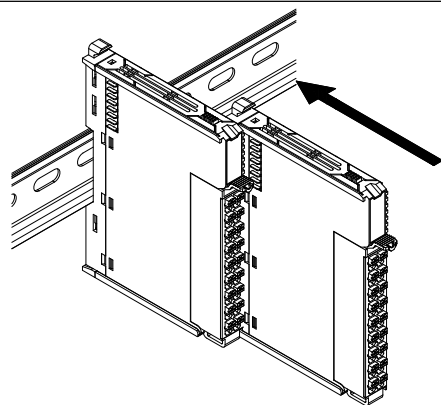

2. The module is mounted on the guide rail. During installation, align the module with the DIN guide rail and press it in the direction indicated by the arrow. A clear click sound will be heard when the module is properly secured, as shown in the left image.

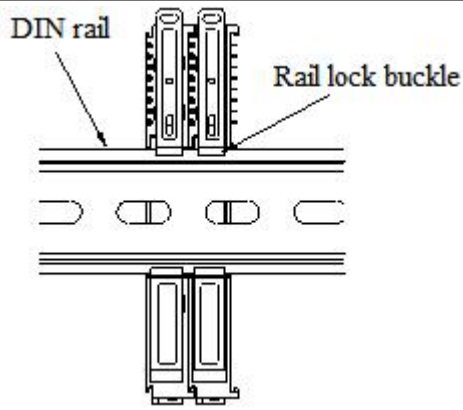

Note: After module installation, the latch will automatically move downward to lock. If it doesn't move, press the top of the latch downward to ensure proper installation.

3) Disassembly steps

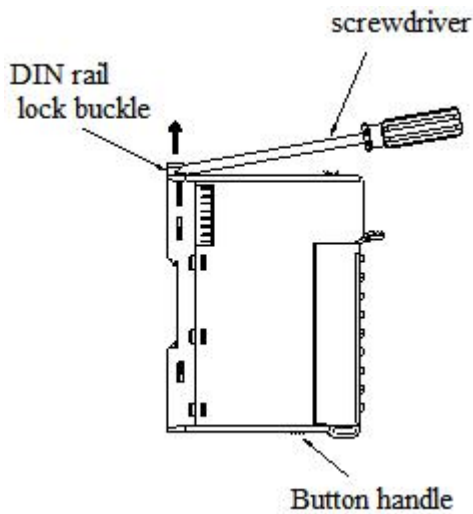

1. Use a screwdriver or similar tool to pry up the guide rail lock, as shown in the left image:

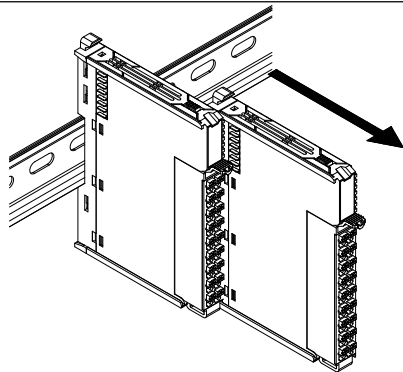

2. Pull the module straight forward from the buckle position (the raised part), then press down the top of the buckle as shown in the left image.

10.2.5.4 Installation Environment

This product supports four installation orientations: horizontal, vertical, top-mounted on electrical cabinets, and bottom-mounted. Horizontal installation is recommended. The cooling system utilizes natural convection. To ensure proper ventilation and heat dissipation while maintaining sufficient wiring clearance, a minimum clearance must be maintained around the product, as shown in the figure below.

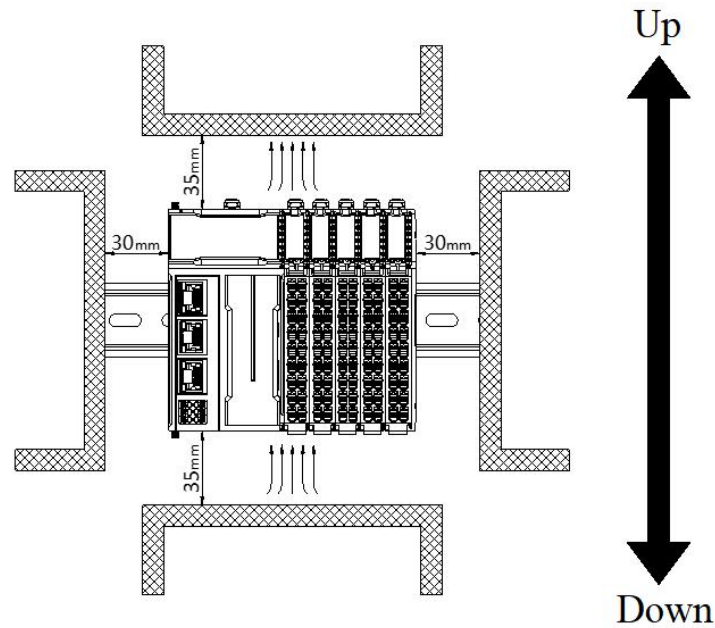

If the product is surrounded by high-temperature heat source equipment (heaters, transformers, high-resistance components, etc.), maintain a minimum clearance of 100mm between the product and such equipment.

10.2.5.5 Equipment Wiring

When wiring the module, the connectors must meet the following requirements:

Suitable wire gauge	
National standard/mm ²	American-Standard /AWG
0.3	22
0.5	20
0.75	18
1.0	18
1.5	16

If using other wire-type terminal lugs, press them onto the stranded wire as shown in the figure below for shape and size requirements.

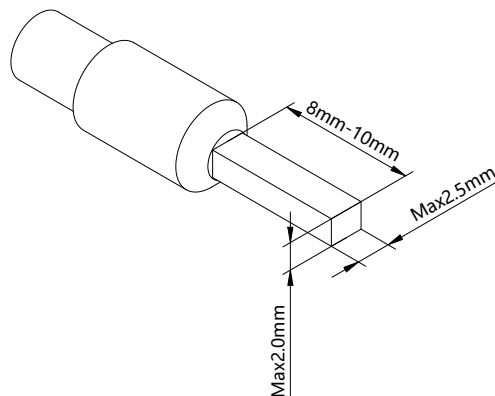

10.2.6 Configuration Module

To add an extension module: First, double-click the space in the 'CPU Architecture' section. Then, in the 'Insert Body Extension Module' dialog box that appears, select 'XF_E1HSC' to add the module. The system will automatically create an instance of the 'XJ_HSC_FreeEncoder' axis variable in the 'SoftMotion General Axis Pool' after the module is added.

Configuring LF Series Remote I/O: For detailed configuration examples, refer to the LF Series Remote I/O User Manual.

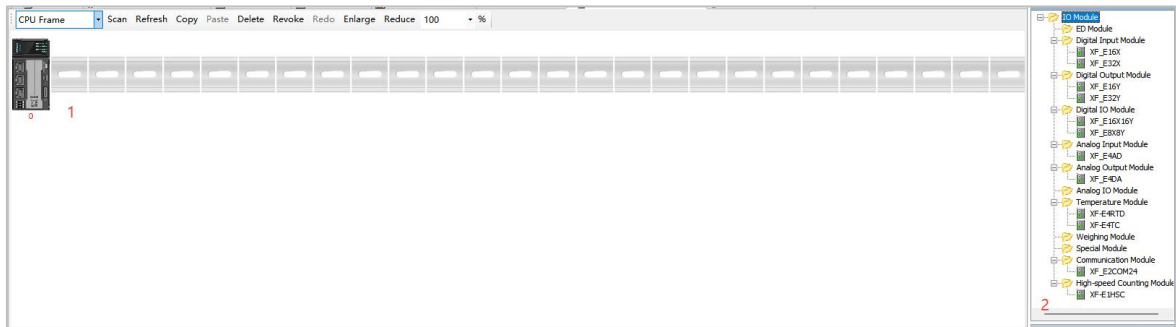

10.2.7 Instruction Introduction

When using the XF-E1HSC with XS Studio, both the XSF5 host and the LFC3-AP host are compatible with the following FB function blocks.

Function block name	Explanation
XJ_Counter_Enable_Ex	Enable counter, count, and measure frequency
XJ_Counter_Compare_Ex	The counter settings are consistent with the output.
XJ_Counter_PresetValue_Ex	Write the counter preset value, including internal preset, external preset, and Z-phase preset.
XJ_TouchProbe_Ex	counter read latch position or latch time function
XJ_MeasurePulseWidth_Ex	Read the pulse width measurement from the counter
XJ_Counter_Reset_Ex	Counter reset error

10.2.7.1 Counter Enablement XJ_Counter_Enable_Ex

Enable high-speed counter [XJ_Counter_Enable_Ex]			
Execution conditions	normally open normally closed trigger	Applicable device	XF-E1HSC module
firmware requirements	V2.0.0 and later	Software Requirements	XS Studio V2.3.1 or later
Library	XJ_HSC		

instruct	name	graphic presentation	ST expression
XJ_Counter_Enable	enable high speed counter		<pre>XJ_Counter_Enable_Ex_0(Counter:=, xEnable:= , xDirectionControl:= , diValue=> , udiFrequency=> , xDirectionState=> , xValid=> , xBusy=> , xError=> , eErrorID=>);</pre>

1) Input variables

input variable	name	data type	domain of validity	initial value	description
Counter	high speed counting input port	XJ_COUNTER_REF	-	-	Add XF-E1HSC auto-instance. Select the instance name of the corresponding high-speed counter.
xEnable	enable	BOOL	TRUE, FALSE	FALSE	Enable the counter to count continuously
xDirectionControl	direction	BOOL	TRUE, FALSE	FALSE	0: A phase priority (default) 1: B phase priority

2) Output variables

output variable	name	data type	domain of validity	initial value	description
diValue	high speed count value	DINT	data area	0	high speed count value
udiFrequency	Pulse frequency measurement value	UDINT		0	Unit: Hz. For low frequencies, use the interface to measure the period.
xDirectionState	direction	BOOL	TRUE, FALSE	FALSE	0: Increment count 1: Count reduction
xValid	Counter count status	BOOL	TRUE, FALSE	FALSE	0: The counter stops counting 1: The counter is counting normally
xBUSY	Busy	BOOL	TRUE, FALSE	FALSE	
xError	mismatch	BOOL	TRUE, FALSE	FALSE	

output variable	name	data type	domain of validity	initial value	description
eErrorID	type of error	HSIO_ERROR	-	0	

10.2.7.2 Counter comparison output XJ_Counter_Compare_Ex

Counter comparison output [XJ_Counter_Compare_Ex]			
Execution conditions	edge triggering	Applicable device	XF-E1HSC module
firmware requirements	V2.0.0 and later	Software Requirements	XS Studio V2.3.1 or later
Library	XJ_HSC		

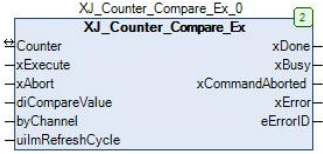
instruct	name	graphic presentation	ST expression
XJ_Counter_Compare	Consistent output		<pre>XJ_Counter_Compare_Ex_0(Counter:= , xExecute:= , xAbort:= , diCompareValue:= , byChannel:= , uiImRefreshCycle:= , xDone=> , xBusy=> , xCommandAborted=> , xError=> , eErrorID=>);</pre>

1) Input variables

input variable	name	data type	domain of validity	initial value	description
Counter	high speed counting input port	XJ_COUNTER_REF	-	-	
xExecute	detonate by contact	BOOL	TRUE, FALSE	FALSE	detonate by contact
xAbort	Termination comparison	BOOL	TRUE, FALSE	FALSE	valid rising edge
diCompareValue	Specify comparison value	DINT	-	0	
byChannel	channel selection	Byte	1-4	1	1-4 corresponds to Y0-Y3
uiImRefreshCycle	Hardware direct output time	UINT	-	0	Unit: 100µs, maximum output time is 3000ms

2) Output variables

output variable	name	data type	domain of validity	initial value	description
xDone	Complete the flag	BOOL	TRUE, FALSE	FALSE	The flag is TRUE after the command is executed.
xBusy	Running	BOOL	TRUE, FALSE	FALSE	
xCommandAborted	Stop the function block	BOOL	TRUE, FALSE	FALSE	
xError	mismatch	BOOL	TRUE, FALSE	FALSE	
eErrorID	type of error	HSIO_ERROR	-	0	

10.2.7.3 Writing preset values to XJ_Counter_PresetValue_Ex

Write preset value to [XJ_Counter_PresetValue_Ex]			
Execution conditions	edge triggering	Applicable device	XF-E1HSC module
firmware requirements	V2.0.0 and later	Software Requirements	XS Studio V2.3.1 or later
Library	XJ_HSC		

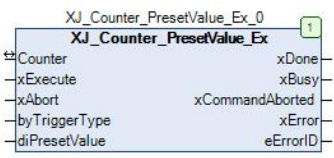
instruct	name	graphic presentation	ST expression
XJ_Counter_PresetValue	write preset value		<pre>XJ_Counter_PresetValue_Ex_0(Counter:= , xExecute:= , xAbort:= , byTriggerType:= , diPresetValue:= , xDone=> , xBusy=> , xCommandAborted=> , xError=> , eErrorID=>);</pre>

1) Input variables

input variable	name	data type	domain of validity	initial value	description
Counter	high speed counting input port	XJ_COUNTER_REF	-	-	High-speed counter requires a high-speed count input (see function description)
xExecute	detonate by contact	BOOL	TRUE, FALSE	FALSE	detonate by contact
xAbort	Cancel	BOOL	TRUE,	FALSE	valid rising edge

input variable	name	data type	domain of validity	initial value	description
	preset		FALSE		
byTriggerType	Trigger type	Byte	-	0	Internal Trigger: 1 DI Trigger: 2 Phase Z Trigger: 3
diPresetValue	preset value	DINT	data area	0	Write high-speed counter preset value

2) Output variables

output variable	name	data type	domain of validity	initial value	description
xDone	Complete the flag	BOOL	TRUE,FALSE	FALSE	Set the flag to TRUE after writing
xBusy	Running	BOOL	TRUE,FALSE	FALSE	
xCommandAborted	Stop the function block	BOOL	TRUE,FALSE	FALSE	
xError	mismatch	BOOL	TRUE,FALSE	FALSE	
eErrorID	type of error	HSIO_ERROR	-	0	

10.2.7.4 Counter Probe XJ_TouchProbe_Ex

Counter probe [XJ_TouchProbe_Ex]			
Execution conditions	edge triggering	Applicable device	XF-E1HSC module
firmware requirements	V2.0.0 and later	Software Requirements	XS Studio V2.3.1 or later
Library	XJ_HSC		

instruct	name	graphic presentation	ST expression
----------	------	----------------------	---------------

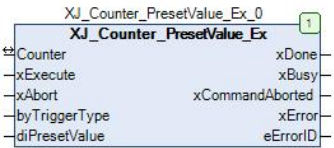
XJ_TouchProbe	probe	 <p>The diagram shows a block named 'XJ_Counter_PresetValue_Ex_0' with several ports: Counter (input), xExecute (input), xAbort (input), byTriggerType (input), diPresetValue (input), xDone (output), xBusy (output), xCommandAborted (output), xError (output), and eErrorID (output).</p>	<pre>XJ_Counter_PresetValue_Ex_0(Counter:= , xExecute:= , xAbort:= , byTriggerType:= , diPresetValue:= , xDone=> , xBusy=> , xCommandAborted=> , xError=> , eErrorID=>);</pre>
---------------	-------	--	---

1) Input variables

input variable	name	data type	domain of validity	initial value	description
Counter	high speed counting input port	XJ_COUNTER_REF	-	-	High-speed counter requires a high-speed count input (see function description)
xExcute	detonate by contact	BOOL	TRUE,FALSE	FALSE	detonate by contact
xAbort	terminant probe	BOOL	TRUE,FALSE	FALSE	valid rising edge
byProbeId	Specify the input point	Byte	1-2	0	1: First probe 2: Second probe
byEdgeType	Edge type	Byte	0-2	0	0: rising edge 1: Falling edge 2: rising edge + falling edge
byInputType	External Trigger Selection	Byte	0-1	0	0: DI 1: Z phase

2) Output variables

output variable	name	data type	domain of validity	initial value	description
diTouchVaulePos	rising edge latch value	DINT		0	
diTouchVauleNeg	falling edge latch value	DINT		0	
diTouchTimePos	rising edge latch time	LINT			
diTouchTimeNeg	falling edge latch time	LINT			
xDone	Complete the flag	BOOL	TRUE, FALSE	FALSE	Set the flag to TRUE after writing
xBusy	Running	BOOL	TRUE, FALSE	FALSE	
xCommandAborted	Stop the function block	BOOL	TRUE, FALSE	FALSE	
xError	mismatch	BOOL	TRUE,	FALSE	

output variable	name	data type	domain of validity	initial value	description
			FALSE		
eErrorID	type of error	HSIO_ERROR	-	0	

10.2.7.5 Measure Pulse Width XJ_MeasurePulseWidth_Ex

Measure pulse width [XJ_MeasurePulseWidth_Ex]			
Execution conditions	normally open normally closed trigger	Applicable device	XF-E1HSC module
firmware requirements	V2.0.0 and later	Software Requirements	XS Studio V2.3.1 or later
Library	XJ_HSC		

instruct	name	graphic presentation	ST expression
XJ_MeasurePulseWidth	Read the pulse width measurement from the counter		<pre>XJ_MeasurePulseWidth_Ex_0(Counter:= , xEnable:= , eMode:= , udiValue=> , xDone=> , xBusy=> , xError=> , eErrorID=>);</pre>

1) Input variables

input variable	name	data type	domain of validity	initial value	description
Counter	high speed counting input port	XJ_COUNTER_REF	-	-	High-speed counter requires a high-speed count input (see function description)
xEnable	Always on/Off	BOOL	TRUE,FALSE	FALSE	always on enable
eMode	Measure high/low level pulse width	HSC_PULSEWIDTH_TYPE	0,1	0	0: High external signal (measuring high-level pulse width); 1: Low external signal (measuring low-level pulse width)

2) Output variables

output variable	name	data type	domain of validity	initial value	description
-----------------	------	-----------	--------------------	---------------	-------------

output variable	name	data type	domain of validity	initial value	description
udiValue	measured value	UDINT		0	
xDone	Complete the flag	BOOL	TRUE,FALSE	FALSE	Set the flag to TRUE after writing
xBusy	Running	BOOL	TRUE,FALSE	FALSE	
xError	mismark	BOOL	TRUE,FALSE	FALSE	
eErrorID	type of error	HSIO_ERROR	-	0	

10.2.7.6 Counter Reset Error XJ_Counter_Reset_Ex

Counter reset error [XJ_Counter_Reset_Ex]			
Execution conditions	edge triggering	Applicable device	XF-E1HSC module
firmware requirements	V2.0.0 and later	Software Requirements	XS Studio V2.3.1 or later
Library	XJ_HSC		

instruct	name	graphic presentation	ST expression
XJ_Counter_Reset	Clear errors		<pre>XJ_Counter_Reset_0(Counter:= , xExcute:= , xDone=> , xBusy=> , xError=> , eErrorID=>);</pre>

1) Input variables

input variable	name	data type	domain of validity	initial value	description
Counter	high speed counting input port	XJ_COUNTER_REF	-	-	High-speed counter requires a high-speed count input (see function description)
xExcute	detonate by contact	BOOL	TRUE,FALSE	FALSE	detonate by contact

2) Output variables

output variable	name	data type	domain of validity	initial value	description
xDone	Complete the flag	BOOL	TRUE,FALSE	FALSE	After completion, the flag is TRUE
xBusy	Running	BOOL	TRUE,FALSE	FALSE	
xError	mismark	BOOL	TRUE,FALSE	FALSE	

eErrorID	type of error	HSIO_ERROR	-	0	
----------	---------------	------------	---	---	--

10.2.8 Functions and Settings

10.2.8.1 General Functions

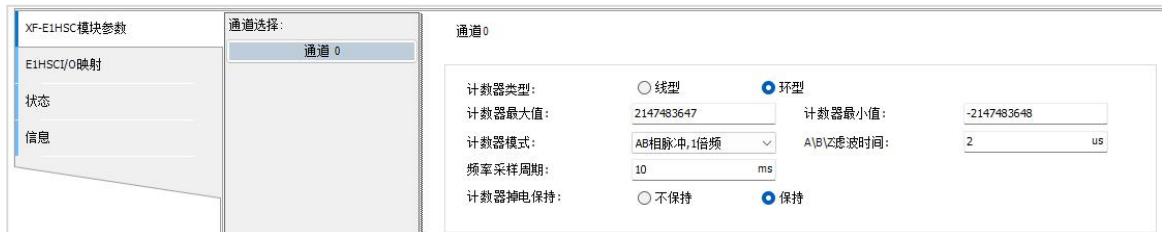

■ Counter type

The counter data type is a 32-bit signed number (ranging from -2147483648 to 2147483647). The counter types include ring counters and linear counters.

● ring counter

The ring counter counts between a maximum and a minimum. It jumps to the minimum when the forward count exceeds the maximum, and to the maximum when the reverse count is less than the minimum.

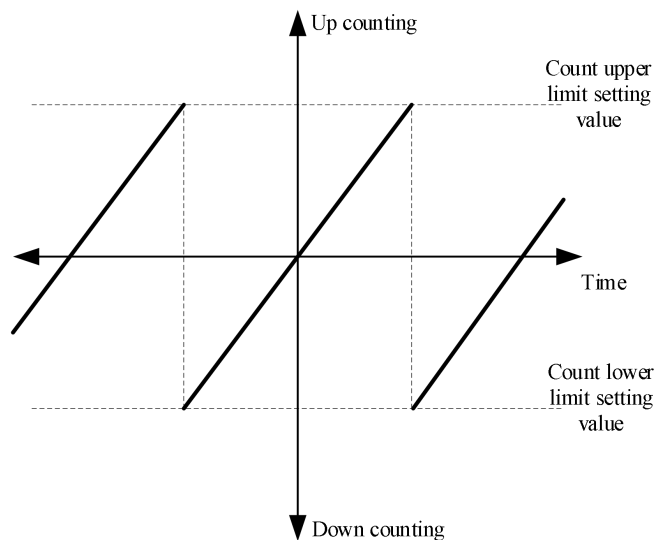

● linear counter

The linear counter counts before reaching the maximum or minimum value. It stops counting when the forward count reaches the maximum or the reverse count reaches the minimum. An overflow alarm is triggered when the current count value exceeds the set limit.

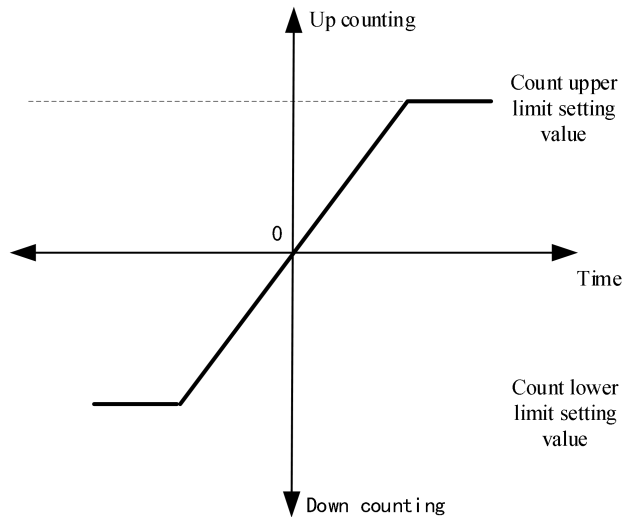

■ Counter mode

Mode	Waveform
Single phase (P)	A phase
Pulse + direction	A phase B phase
A/B phase 1/2/4 times frequency	A phase B phase 4 times frequency ABX1 4 times frequency ABX2 4 times frequency ABX4
CW/CCW input	A phase B phase

■ counter direction control

The counter's counting direction can be adjusted via PDO, with options to prioritize either Phase A or Phase B.

● AB Xiang

When A phase is prioritized, the counter increments when A phase leads B phase.

When set to B phase priority, the counter increments when A phase lags behind B phase.

- uniphase

Only for phase A, no direction control.

- Pulse + Direction

When A phase is prioritized, the counter increments upon receiving a high-level signal from B phase.
When B phase priority is set, the counter increments upon receiving a low-level signal from B phase.

- CW/CCW

When A-phase priority is set, the counter increments if A-phase counts.

When B phase priority is set, the counter increments if B phase has a count.

■ Counter Application Examples

For example: Power detection is disabled, the counter type is set to circular, the counter mode is 1x frequency of AB phase, the count value is power loss hold, and the maximum and minimum values of the counter are set to default.

Channel 0

Counter Type: Linear Circular

Maximum Value of Counter: Minimum Value of Counter:

Counter Mode: A|B|Z Filtering Time:

Frequency Sampling Period: Power Detection: OFF ON

Counter Power-off Retention: Discard Save

The rotation encoders are as follows:

- Encoder forward (increment)

Parameter	Type	Value	Default Value	Address	Description
XJ_Counter_Enable_Ex_0	XJ_Counter_Enable...				
Counter	REFERENCE TO XJ_...				Data type XJ_COUNTLER_REF
xEnable	BOOL	TRUE			Normally open to enable counting
xDirectionControl	BOOL	FALSE			FALSE: A-phase priority (default) TRUE: B-phase priority
diValue	DINT	29398			High speed count value
udiFrequency	UDINT	0			Pulse frequency measurement value (single...
xDirectionState	BOOL	FALSE			FALSE: Increase Count TRUE: Countdown
xValid	BOOL	TRUE			FALSE: Counter stops counting TRUE: Counter is normal ...
xBusy	BOOL	TRUE			Busy
xError	BOOL	FALSE			Error flag
eErrorID	HSC_ERROR	ERR_OK			Error Type

```

1 XJ_Counter_Enable_Ex_0(
2   Counter:=XJ_HSC_FreeEncoder ,
3   xEnable:= ,
4   xDirectionControl:= ,
5   diValue=> ,
6   udiFrequency=> ,
7   xDirectionState=> ,
8   xValid=> ,
9   xBusy=> ,
10  xError=> ,
11  eErrorID=> );
    
```

Use the XJ_Counter_Enable_Ex command to enable the counter. After enabling, rotate the encoder. The current count value will be displayed in the high-speed count value of the output parameter, and the output pin 'xDirectionState' will be set to FALSE.

- encoder inversion (count down)

Parameter	Type	Value	Default Value	Address	Description
XJ_Counter_Enable_Ex_0	XJ_Counter_Enable...				
Counter	REFERENCE TO XJ_...				Data type XJ_COUNTER_REF
xEnable	BOOL	TRUE			Normally open to enable counting
xDirectionControl	BOOL	FALSE			FALSE: A-phase priority (default) TRUE: B-phase priority
dValue	DINT	27938			High speed count value
udiFrequency	UDINT	0			Pulse frequency measurement value (single...
xDirectionState	BOOL	TRUE			FALSE: Increase Count TRUE: Countdown
xValid	BOOL	TRUE			FALSE: Counter stops counting TRUE: Counter is normal ..
xBusy	BOOL	TRUE			Busy
xError	BOOL	FALSE			Error flag
eErrorID	HSC_ERROR	ERR_OK			Error Type

```

1 XJ_Counter_Enable_Ex_0(
2 Counter:=XJ_HSC_FreeEncoder ,
3 xEnable:= ,
4 xDirectionControl:= ,
5 dValue=> ,
6 udiFrequency=> ,
7 xDirectionState=> ,
8 xValid=> ,
9 xBusy=> ,
10 xError=> ,
11 eErrorID=> );
    
```

Use the XJ_Counter_Enable_Ex command to enable the counter. After enabling, rotate the encoder to display the current count value in the high-speed output parameter, and set the output pin 'xDirectionState' to TRUE.

■ Error code parameter

Module-level error code (ErrCode_module)		
bit position	meaning	Error level
0	The 24V input power of the module is abnormal.	Medium
1	Incorrect module parameter assignment	Critical
2	An internal module error occurred and the user layer cannot fix it	Critical
3	Version mismatch	Critical

■ Channel level code parameter

Channel level error code (ErrCode_CH)		
bit position	meaning	Error level
0	Input frequency overload	Medium

10.2.8.2 Pre-installed Functions

There are three kinds of counter preset methods, which are internal command, external digital input terminal and Z signal.

■ Examples of pre-configured feature applications

For example: Change the current speedometer value to 200.

(1) Internal preset write

Set the counter to 200.

First, execute the counter enable instruction, then use the preset value write instruction to write the preset value through the internal preset function. The preset value set successfully will be written into the current count value.

Command parameter configuration:

Parameter	Type	Value	Default Value	Address	Description
XJ_Counter_PresetValue_Ex_0	XJ_Counter_PresetV...				
Counter	REFERENCE TO XJ_...				Data type XJ_COUNTER_REF
xExecute	BOOL	TRUE			Trigger (effective rising edge)
xAbort	BOOL	FALSE			Terminate preset (effective rising edge)
byTriggerType	BYTE	1			Trigger type (1: internal trigger 2: D trigger 3: Z phase angle)
diPresetValue	DINT	200			Preset value
xDone	BOOL	TRUE			Completion mark
xBusy	BOOL	FALSE			Running
xCommandAborted	BOOL	FALSE			Function block termination execution
xError	BOOL	FALSE			Error flag
eErrorID	HSC_ERROR	ERR_OK			Error Type

The effect is shown in the figure:

Parameter	Type	Value	Default Value	Address	Description
Counter	REFERENCE TO XJ_...				Data type XJ_COUNTER_REF
xEnable	BOOL	TRUE			Normally open to enable counting
xDirectionControl	BOOL	FALSE			FALSE: phase priority (default) TRUE: B phase priority
diValue	DINT	200			High speed count value
udiFrequency	UDINT	0			Pulse frequency measurement value (unit: h). The frequency can be
xDirectionState	BOOL	TRUE			FALSE: Countdown TRUE: Countdown
xValid	BOOL	TRUE			FALSE: Counter stops counting TRUE: Counter is counting normally
xBusy	BOOL	TRUE			Busy
xError	BOOL	FALSE			Error flag
eErrorID	HSC_ERROR	ERR_OK			Error Type
XJ_Counter_PresetValue_Ex_0	XJ_Counter_PresetV...				
Counter	REFERENCE TO XJ_...				Data type XJ_COUNTER_REF
xExecute	BOOL	TRUE			Trigger (effective rising edge)
xAbort	BOOL	FALSE			Terminate preset (effective rising edge)
byTriggerType	BYTE	1			Trigger type (1: internal trigger 2: D trigger 3: Z-phase trigger)
diPresetValue	DINT	200			Preset value
xDone	BOOL	TRUE			Completion mark
xBusy	BOOL	FALSE			Running
xCommandAborted	BOOL	FALSE			Function block termination execution
xError	BOOL	FALSE			Error flag
eErrorID	HSC_ERROR	ERR_OK			Error Type

```

1 XJ_Counter_Enable_Ex_0(
2   Counter:=XJ_HSC_FreeEncoder ,
3   xEnable:= ,
4   xDirectionControl:= ,
5   diValue:= ,
6   udiFrequency:= ,
7   xDirectionState:= ,
8   xValid:= ,
9   xBusy:= ,
10  xError:= ,
11  eErrorID:= );
12
13 XJ_Counter_PresetValue_Ex_0(
14   Counter:=XJ_HSC_FreeEncoder ,
15   xExecute:= ,
16   xAbort:= ,
17   byTriggerType:= ,
18   diPresetValue:= ,
19   xDone:= ,
20   xBusy:= ,
21   xCommandAborted:= ,
22   xError:= ,
23   eErrorID:= );
    
```

(2) External digital quantity preset

For example, set the X0 terminal function to "preset":

Input Port Settings

X0

Function Selection: Preset v

Logic Level: Positive v

Filtering Time: 2 us

X1

Function Selection: General Input v

Logic Level: Positive v

Filtering Time: 2 us

Set the counter to 200.

First execute the counter enable instruction, then use the preset value write instruction to activate the internal preset function. When the external X signal input reaches its rising edge, the preset value is written, and the preset value is successfully set in the current count value.

Command parameter configuration:

Parameter	Type	Value	Default Value	Address	Description
XJ_Counter_PresetValue_Ex_0	XJ_Counter_PresetV...				
Counter	REFERENCE TO XJ_...				Data type XJ_COUNTER_REF
xExecute	BOOL	TRUE			Trigger (effective rising edge)
xAbort	BOOL	FALSE			Terminate preset (effective rising edge)
byTriggerType	BYTE	1			Trigger type (1: internal trigger 2: D trigger 3: Z phase angle)
diPresetValue	DINT	200			Preset value
xDone	BOOL	TRUE			Completion mark
xBusy	BOOL	FALSE			Running
xCommandAborted	BOOL	FALSE			Function block termination execution
xError	BOOL	FALSE			Error flag
eErrorID	HSC_ERROR	ERR_OK			Error Type

The effect is as follows:

Parameter	Type	Value	Default Value	Address	Description
Counter	REFERENCE TO XJ_...				Data type XJ_COUNTER_REF
xEnable	BOOL	TRUE			Normally open to enable counting
xDirectionControl	BOOL	FALSE			FALSE: phase priority (default) TRUE: B phase priority
diValue	DINT	200			High speed count value
udiFrequency	UDINT	0			Pulse frequency measurement value (unit: Hz). The frequency can be...
xDirectionState	BOOL	TRUE			FALSE: Countdown TRUE: Countdown
xValid	BOOL	TRUE			FALSE: Counter stops counting TRUE: Counter is counting normally
xBusy	BOOL	TRUE			Busy
xError	BOOL	FALSE			Error flag
eErrorID	HSC_ERROR	ERR_OK			Error Type
XJ_Counter_PresetValue_Ex_0	XJ_Counter_PresetV...				
Counter	REFERENCE TO XJ_...				Data type XJ_COUNTER_REF
xExecute	BOOL	TRUE			Trigger (effective rising edge)
xAbort	BOOL	FALSE			Terminate preset (effective rising edge)
byTriggerType	BYTE	1			Trigger type (1: internal trigger 2: D trigger 3: Z phase trigger)
diPresetValue	DINT	200			Preset value
xDone	BOOL	TRUE			Completion mark
xBusy	BOOL	FALSE			Running
xCommandAborted	BOOL	FALSE			Function block termination execution
xError	BOOL	FALSE			Error flag
eErrorID	HSC_ERROR	ERR_OK			Error Type

```

1 XJ_Counter_Enable_Ex_0(
2   Counter:=XJ_HSC_FreeEncoder,
3   xEnable:=,
4   xDirectionControl:=,
5   diValue=>,
6   udiFrequency=>,
7   xDirectionState=>,
8   xValid=>,
9   xBusy=>,
10  xError=>,
11  eErrorID=> );
12 XJ_Counter_PresetValue_Ex_0(
13  Counter:=XJ_HSC_FreeEncoder,
14  xExecute:=,
15  xAbort:=,
16  byTriggerType:=,
17  diPresetValue:=,
18  xDone=>,
19  xBusy=>,
20  xCommandAborted=>,
21  xError=>,
22  eErrorID=> );
    
```

(3) Z signal preset

Set the counter to 200.

First, execute the counter enable instruction, then use the preset value write instruction to activate the internal preset function. When the rising edge of the external Z signal arrives, the preset value is written, and the set preset value is successfully written into the current count value.

Command parameter configuration:

Parameter	Type	Value	Default Value	Address	Description
XJ_Counter_PresetValue_Ex_0	XJ_Counter_PresetV...				
Counter	REFERENCE TO XJ_...				Data type XJ_COUNTER_REF
xExecute	BOOL	TRUE			Trigger (effective rising edge)
xAbort	BOOL	FALSE			Terminate preset (effective rising edge)
byTriggerType	BYTE	1			Trigger type (1: internal trigger 2: D trigger 3: Z phase angle)
diPresetValue	DINT	200			Preset value
xDone	BOOL	TRUE			Completion mark
xBusy	BOOL	FALSE			Running
xCommandAborted	BOOL	FALSE			Function block termination execution
xError	BOOL	FALSE			Error flag
eErrorID	HSC_ERROR	ERR_OK			Error Type

The effect is as follows:

Parameter	Type	Value	Default Value	Address	Description
Counter	REFERENCE TO XJ_...				Data type XJ_COUNTER-REF
xEnable	BOOL	TRUE			Normally open to enable counting
xDirectionControl	BOOL	FALSE			FALSE: B phase priority (default) TRUE: B phase priority
diValue	DINT	200			High speed count value
udiFrequency	UDINT	0			Pulse frequency measurement value (unit: Hz). The frequency can be...
xDirectionState	BOOL	TRUE			FALSE: Countdown TRUE: Countdown
xValid	BOOL	TRUE			FALSE: Counter stops counting TRUE: Counter is counting normally
xBusy	BOOL	FALSE			Busy
xError	BOOL	FALSE			Error flag
eErrorID	HSC_ERROR	ERR_OK			Error Type
XJ_Counter_PresetValue_Ex_0	XJ_Counter_PresetV...				
Counter	REFERENCE TO XJ_...				Data type XJ_COUNTER-REF
xExecute	BOOL	TRUE			Trigger (effective rising edge)
xAbort	BOOL	FALSE			Terminate preset (effective rising edge)
byTriggerType	BYTE	1			Trigger type (1: internal trigger 2: D trigger 3: Z-phase trigger)
diPresetValue	DINT	200			Preset value
xDone	BOOL	TRUE			Completion mark
xBusy	BOOL	FALSE			Running
xCommandAborted	BOOL	FALSE			Function block termination execution
xError	BOOL	FALSE			Error flag
eErrorID	HSC_ERROR	ERR_OK			Error Type

```

1 XJ_Counter_Enable_Ex_0(
2   Counter:=XJ_HSC_FreeEncoder ,
3   xEnable:= ,
4   xDirectionControl:= ,
5   diValue:= ,
6   udiFrequency:= ,
7   xDirectionState:= ,
8   xValid:= ,
9   xBusy:= ,
10  xError:= ,
11  eErrorID:= );
12
13 XJ_Counter_PresetValue_Ex_0(
14   Counter:=XJ_HSC_FreeEncoder ,
15   xExecute:= ,
16   xAbort:= ,
17   byTriggerType:= ,
18   diPresetValue:= ,
19   xDone:= ,
20   xBusy:= ,
21   xCommandAborted:= ,
22   xError:= ,
23   eErrorID:= );
    
```

10.2.8.3 Gate Control Function

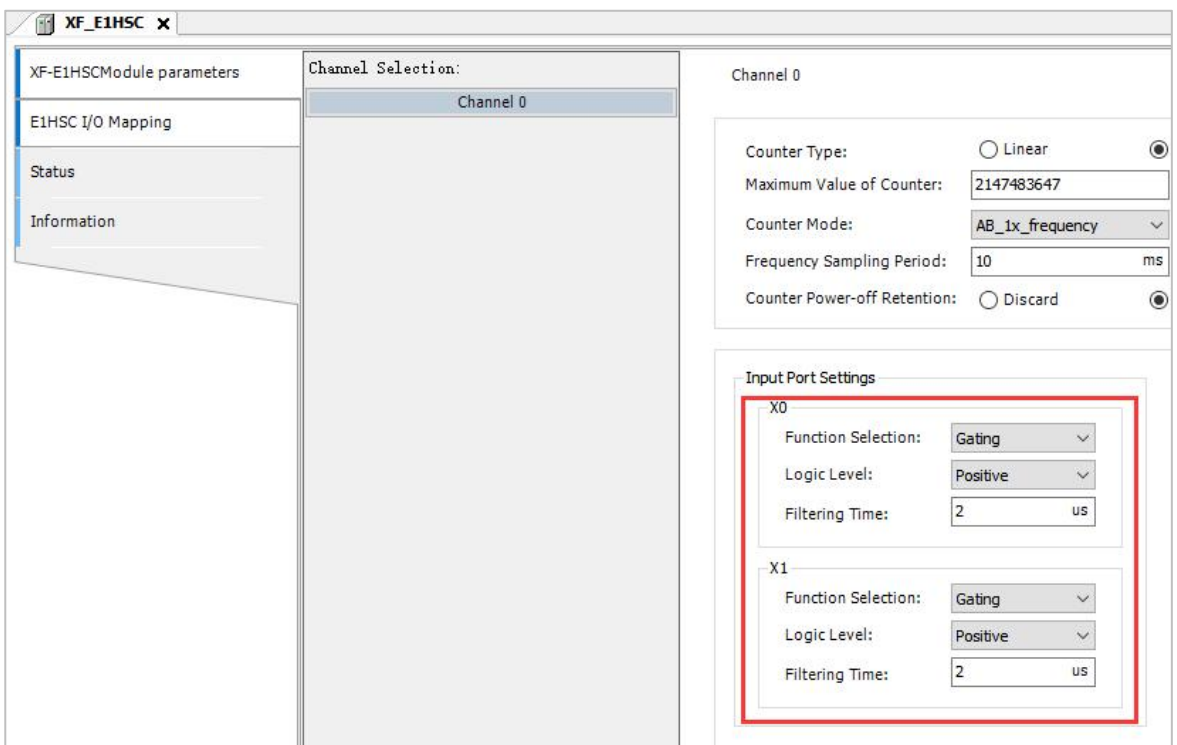

The gate function is a hardware enable control that allows users to configure X0 or X1 for gate function operation. When the gate function is disabled, the counter is enabled solely through control commands. When the gate function is enabled, the counter starts counting only when both control commands and gate input signals are active. Once the counter begins counting, the status word flag becomes active. The control logic is illustrated in the diagram below:

- Do not use the gate function

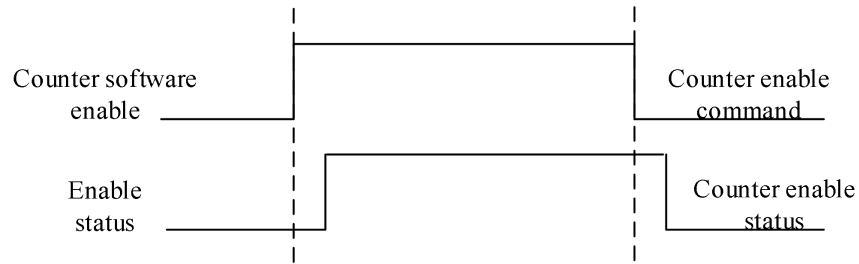

- Use the gate function

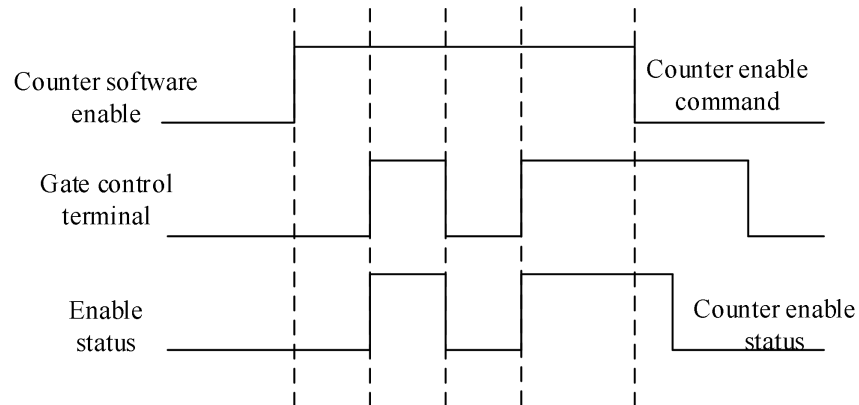

10.2.8.4 Probe Functions

The probe function locks the DC time and counter values when a specific signal occurs. Each channel can set up to two probe terminals, and each probe supports both rising and falling edge latching.

For example, the X0 terminal acts as a probe to trigger the signal, with the rising edge condition locking the probe's position.

Set the X0 terminal function to 1 "Probe":

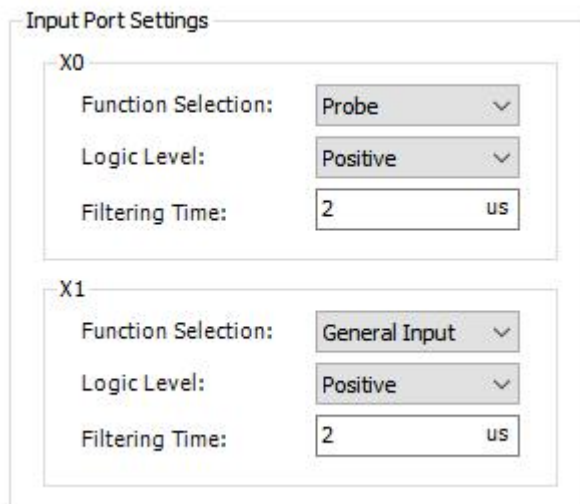

First, the counter enable instruction is executed, then the counter probe instruction is used to trigger the external probe signal. After the instruction is successfully executed, the current position and the current DC time value are locked in the instruction output parameters.

Command parameter configuration:

XJ_TouchProbe_Ex_0	XJ_TouchProbe_Ex				
Counter	REFERENCE TO XJ_...				Data type XJ_COUNTER-REF
xExecute	BOOL	FALSE			Trigger (effective rising edge)
xAbort	BOOL	FALSE			Terminate preset (effective rising edge)
byProbeMode	BOOL	FALSE			FALSE: Single TRUE: Continuous angle trigger
byProbeId	BYTE	1			Specify input points 1-2 corresponding to the first or second probe
byEdgeType	BYTE	0			Edge type 0: rising edge 1: falling edge 2: rising edge+falling edge
byInputType	BYTE	0			External trigger selection 0: DI 1: Z phase
diTouchVaulePos	DINT	0			Rising edge latch value
diTouchVauleNeg	DINT	0			Falling edge latch value
diTouchTimePos	LINT	0			Rising edge latch time (unit: ns)
diTouchTimeNeg	LINT	0			Falling edge latch time (unit: ns)
byTouchNum	BYTE	0			Thorium counting
xDone	BOOL	FALSE			Completion mark
xBusy	BOOL	FALSE			Running
xCommandAborted	BOOL	FALSE			Function block termination execution
xError	BOOL	FALSE			Error flag
eErrorID	HSC_ERROR	ERR_OK			Error Type

The effect is as follows:

表达式	类型	值	准备值	地址	注释
XJ_Counter_Enable_Ex_0	XJ_Counter_Enable...				
Counter	REFERENCE TO XJ_...				Data type XJ_COUNTER-REF
xEnable	BOOL	TRUE			Normally open to enable counting
xDirectionControl	BOOL	FALSE			FALSE: phase priority (default) TRUE: B phase priority
diValue	DINT	5084			High speed count value
udiFrequency	UDINT	0			Pulse frequency measurement value (unit: h). The frequency can be n
xDirectionState	BOOL	TRUE			FALSE: Countdown TRUE: Countdown
xValid	BOOL	TRUE			FALSE: Counter stops counting TRUE: Counter is counting normally
xBusy	BOOL	TRUE			Busy
xError	BOOL	FALSE			Error flag
eErrorID	HSC_ERROR	ERR_OK			Error Type
XJ_TouchProbe_Ex_0	XJ_TouchProbe_Ex				
Counter	REFERENCE TO XJ_...				Data type XJ_COUNTER-REF
xExecute	BOOL	TRUE			Trigger (effective rising edge)
xAbort	BOOL	FALSE			Terminate preset (effective rising edge)
byProbeMode	BOOL	FALSE			FALSE: Single TRUE: Continuous angle trigger
byProbeId	BYTE	1			Specify input points 1-2 corresponding to the first or second probe
byEdgeType	BYTE	0			Edge type 0: rising edge 1: falling edge 2: rising edge+falling edge
byInputType	BYTE	0			External trigger selection 0: DI 1: Z phase
diTouchVaulePos	DINT	5084			Rising edge latch value
diTouchVauleNeg	DINT	0			Falling edge latch value
diTouchTimePos	LINT	914913636120			Rising edge latch time (unit: ns)
diTouchTimeNeg	LINT	0			Falling edge latch time (unit: ns)
byTouchNum	BYTE	0			Probe counting
xDone	BOOL	TRUE			Completion mark
xBusy	BOOL	FALSE			Running
xCommandAborted	BOOL	FALSE			Function block termination execution
xError	BOOL	FALSE			Error flag
eErrorID	HSC_ERROR	ERR_OK			Error Type

```

3   xEnable:= ,
4   xDirectionControl:= ,
5   diValue=> ,
6   udiFrequency=> ,
7   xDirectionState=> ,
8   xValid=> ,
9   xBusy=> ,
10  xError=> ,
11  eErrorID:= []
12  XJ_TouchProbe_Ex_0(
13    Counter:=XJ_HSC_FreeEncoder ,
14    xExecute:= ,

```

10.2.8.5 Comparison of output functions

For example, use Y0 as the comparison output signal.

Set the Y terminal function to "Compare Output":

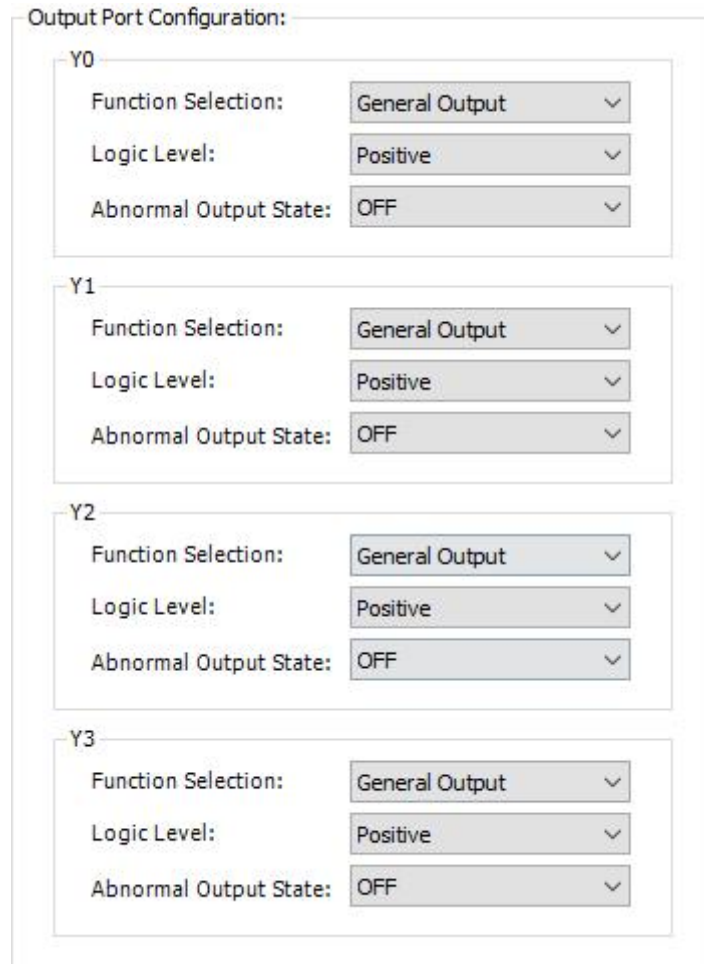

First, execute the counter enable instruction, then use the counter comparison output instruction to set the comparison output value and time. After the instruction is successfully executed, the corresponding Y will output the status of the time.

Command parameter configuration:

XJ_Counter_Compare_Ex_0	XJ_Counter_Compar...				Data type XJ_COUNTER_REF
Counter	REFERENCE TO XJ_...				
xExecute	BOOL	TRUE			Trigger
xAbort	BOOL	FALSE			Terminate comparison
diCompareValue	DINT	7000			Specify comparison value
byChannel	BYTE	1			Channel selection (1-4 correspond to Y0-Y3)
uiImRefreshCycle	UINT	30000			Unit: 0.1ms, maximum output time is 3000 ms
xDone	BOOL	FALSE			Completion mark
xBusy	BOOL	TRUE			Running
xCommandAborted	BOOL	FALSE			Function block terminates operation
xError	BOOL	FALSE			Error flag
eErrorID	HSC_ERROR	ERR_OK			Error Type

The effect is as follows:

表达式	类型	值	准备值	地址	注释
XJ_Counter_Enable_Ex_0	XJ_Counter_Enable...				
Counter	REFERENCE TO XJ_...				Data type XJ_COUNTER_REF
xEnable	BOOL	TRUE			Normally open to enable counting
xDirectionControl	BOOL	FALSE			FALSE: A-phase priority (default) TRUE: B-phase priority
diValue	DINT	9905			High speed count value
udiFrequency	UDINT	0			Pulse frequency measurement value (unit: h)... can be measured th
xDirectionState	BOOL	TRUE			FALSE: Countdown TRUE: Countdown
xValid	BOOL	TRUE			FALSE: Counter stops counting TRUE: Counter is counting normally
xBusy	BOOL	TRUE			Busy
xError	BOOL	FALSE			Error flag
eErrorID	HSC_ERROR	ERR_OK			Praseodymium error type
XJ_Counter_Compare_Ex_0	XJ_Counter_Compar...				
Counter	REFERENCE TO XJ_...				Data type XJ_COUNTER_REF
xExecute	BOOL	TRUE			Trigger
xAbort	BOOL	FALSE			Terminate comparison
diCompareValue	DINT	7000			Specify comparison value
byChannel	BYTE	1			Channel selection (1-4 correspond to Y0-Y3)
uiInRefreshCycle	UBINT	30000			Unit: 0.1ms, maximum output time is 3000 ms
xDone	BOOL	TRUE			Completion mark
xBusy	BOOL	FALSE			Running
xCommandAborted	BOOL	FALSE			Function block terminates operation
xError	BOOL	FALSE			Error flag
eErrorID	HSC_ERROR	ERR_OK			Error Type



```

1 XJ_Counter_Enable_Ex_0(
2 Counter:=XJ_HSC_FreeEncoder ,
3 xEnable:= ,
4 xDirectionControl:= ,
5 diValue=> ,
6 udiFrequency=> ,
7 xDirectionState=> ,
8 xValid=> ,
9 xBusy=> ,
10 xError=> ,
11 eErrorID=> );
12 XJ_Counter_Compare_Ex_0(
13 Counter:=XJ_HSC_FreeEncoder ,
14 xExecute:= ,
15 xAbort:= ,
16 diCompareValue:= ,
17 byChannel:= ,
18 uiInRefreshCycle:= ,
19 xDone=> ,
20 xBusy=> ,

```

10.2.8.6 Encoder Axis Parameter Settings

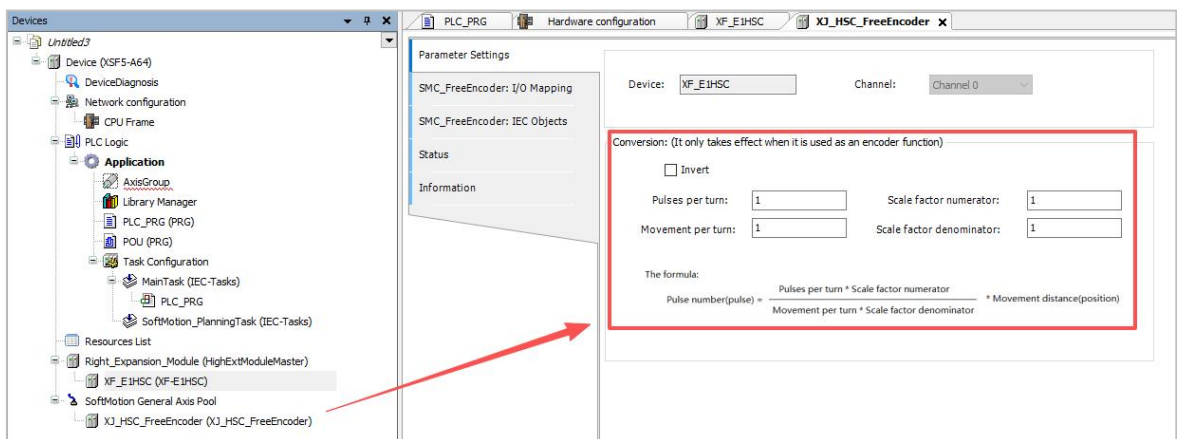
After adding the "XF_E1HSC" module, the axis variable instance interface of "XJ_HSC_FreeEncoder" in "SoftMotionGeneralAxisPool" can be configured as the proportional conversion parameter for encoder axis functionality.



The calculation formula is as follows:

$$\text{Pulse number(pulse)} = \frac{\text{Pulses per turn} * \text{Scale factor numerator}}{\text{Movement per turn} * \text{Scale factor denominator}} * \text{Movement distance(position)}$$

11. Pulse output module unit

11.1 Naming Rules

$\frac{\text{XF}}{\textcircled{1}} - \frac{\text{E}}{\textcircled{2}} \frac{\text{O}}{\textcircled{3}} \frac{\square\square\square}{\textcircled{4}}$

①	Series name	XF:	XF series expansion module
②	referential extension module	E:	Right Extension Module
③	number of channels	1:	1 channel
		2:	2 channel
		4:	4 channel
④	Function type	HSC:	high speed counting
		HSP:	pulse output

11.2 Pulse Output Module Unit XF-E2HSP

11.2.1 Product Overview

XF-E2HSP series pulse output module, this product has 8 channels of digital input and 6 channels of digital output. can support 2 pulse outputs, with a maximum output frequency of 200KHz. It can also be configured as a regular input/output module, suitable for use with XF, XSF series CPU units and XF series communication coupler units.

- 2-channel pulse output with a maximum frequency of 200KHz.
- 8 channels are bipolar inputs and 6 channels are NPN outputs.
- Supports 2 PWM outputs
- 12mm width design.

■ Module Version

Hardware version	Firmware version	function
H2.0	V2.0	The basic functions are now officially operational for the first time.
	V3.0	Add PWM function and adapt to LF series coupler

11.2.2 Module View

1) Explanation of each part

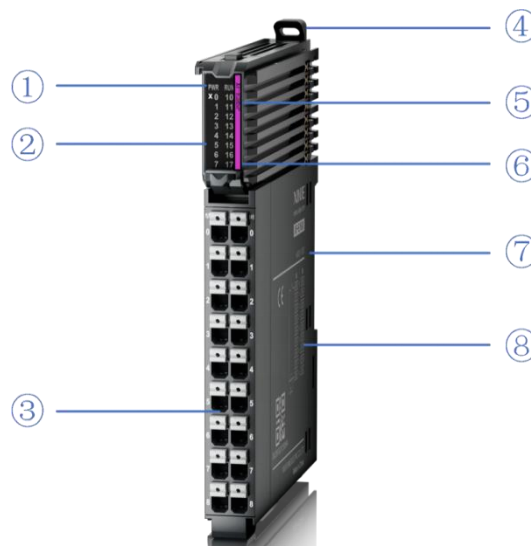

Number	name	Number	name
①	System LED indicator light	②	Channel LED indicator light
③	disconnectable terminal block	④	fastener
⑤	model indication	⑥	Color code for indicator module type
⑦	Module hardware and Firmware version	⑧	hookup

2) System Indicator Light

System Indicator Light	meaning	
PWR (green)	extinct	The module is not powered on
	Always on	All external power supplies for the module are functioning normally (backplane bus power and external 24V input).
	Flash 1Hz*1	The module section is not functioning properly due to a power supply issue.
RUN (green)	Always on	The module is running normally
	Flash 1Hz*1	The module encountered a general error in the log
	extinct	The module encountered a critical error in the log
	10Hz*2	Modeling communication
	Dual Flash*4	firmware update
	Flash*3	The heartbeat is Flash. The hardware is connected normally after power-on.



- *1: The duty cycle is 50%, and the frequency is 1Hz, with a square wave.
- *2: The duty cycle is 50%, and the frequency is 10Hz, with a square wave.
- *3: Indicator light specification: ON:0.2s OFF:1.8s
- *4: The hazard lights are shown below:

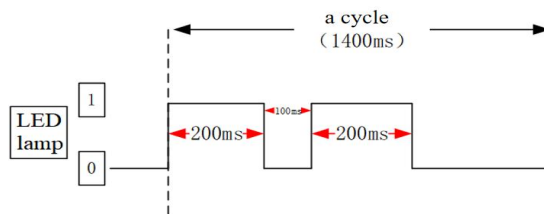

3) Channel indicator light light

model	Channel indicator light		
XF-E2HSP	X00-X03/X10-X13	Always on (green)	The corresponding channel has input/output ON signals
	Y00-Y02/Y10-Y12	go out	No ON signal for input/output on the corresponding channel

4) Color labels

Number	Color		Module type
1		hoar	digital input

Number	Color	Module type
2	gray	digital output & digital mixing module
3	wathet	read analogue input
4	mazarine	analog output
5	green	232&485 serial communication
6	rose hermosa	Temperature signal input
7	white	high speed counting
8	purple	pulse output
9	red	repeater power supply

11.2.3 General Specifications

project		specifications
Operation temperature	Maximum temperature	55°C
	Minimum temperature	-20°C
Transportation/Storage Temperature	Maximum temperature	70°C
	Minimum temperature	-40°C
Environmental humidity (including operation/storage)	superior limit	95%
	lower limit	10%
Levels of protection		IP20
Anti-vibration		Complies with IEC61131-2 under intermittent vibration (frequency 5-9Hz, constant amplitude 3.5mmpeak displacement) and (frequency 9-150Hz, constant acceleration 1.0gpeak acceleration) The continuous shock vibration (5-9Hz, half amplitude 1.75mm displacement) and (9-150Hz, constant acceleration 0.5g, constant frame amplitude) Scan 10 times in each of the X, Y, and Z directions
Shock resistance		Complies with IEC61131-2 standard Impact intensity of 15G (peak) was applied for 11ms on each of three mutually perpendicular axes, with 3 impacts per axis (total 18 impacts).
Operating environment		Non-corrosive gas
Operating altitude		0-2000 meters
Overvoltage class		II: Complies with IEC61131-2
Pollution level		2; Complies with IEC61131-2
Anti-interference EMC		Complies with IEC61131-2 and IEC61000-6-4 Type B
Related certifications		CE

11.2.4 Technical Specifications

project		specifications
input specification	Input channel	8
	Input type	NPN&PNP
	Rated input voltage	DC24V
	Rated input current	4mA
	ON voltage	15v
	ON Input current	2.5mA
	Enter the OFF voltage	5V
	Enter the OFF current	1mA
	Input derating	The system operates at 55°C with a 50% power reduction (when no more than 4 input points are ON simultaneously), or a 10°C reduction when all input points are ON.
	Input resistance ON→OFF Response time (hardware)	1us
	Input resistance OFF→ON Response time (hardware)	1us
Output specifications	outgoing channel	6
	Output type	transistor (NPN)
	Rated load voltage	DC24V (DC21.6V~26.4V)
	Maximum load current	0.5A/1 point
	surge current protection	support
	Leakage current at OFF	below 0.1mA
	ON response time (hardware)	1us
	OFF response time (hardware)	1us
Module specifications	Module dissipation	1W (backplane bus) + 1W (external input)
	Module weight	80g

11.2.5 Installation & Wiring

11.2.5.1 Appearance dimensions

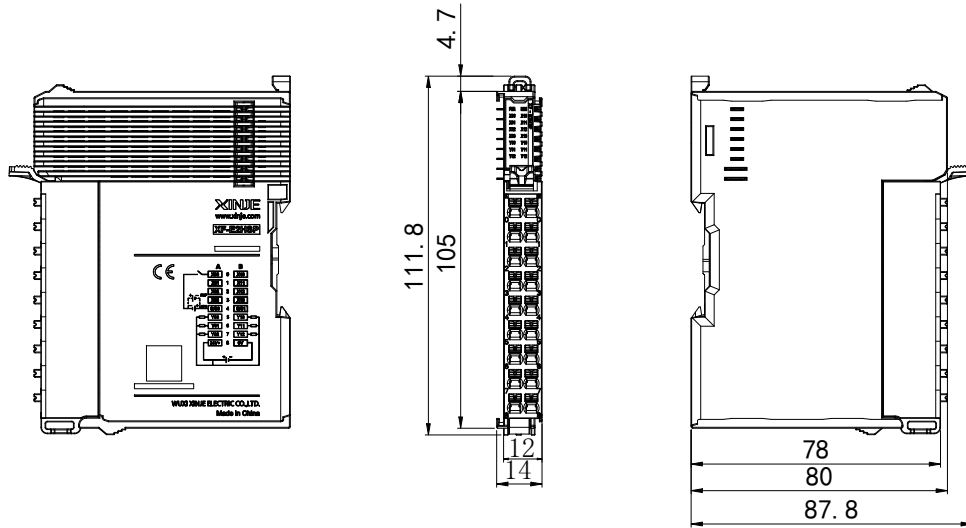

(unit :mm)

11.2.5.2 Terminal Definitions & Wiring

1) Terminal definition

XF-E2HSP				
meaning	A terminal	terminal arrangement	B terminal	meaning
X00: Channel 0 is in limit-up or normal input	0		0	X10: Channel 1 is in limit position or normal input
X01: Channel 0 negative limit or normal input	1		1	X11: Channel 1 negative limit or normal input
X02: Channel 0 origin or normal input	2		2	X12: Channel 1 origin or normal input
X03: Channel 0 emergency stop or normal input	3		3	X13: Channel 1 emergency stop or normal input
S/S0: Common input of channel 0	4		4	S/S1: Common input of channel 1
Y00: Channel 0 pulse or normal output	5		5	Y10: Channel 1 pulse or normal output
Y01: Channel 0 or normal output	6		6	Y11: Channel 1 or normal output
Y02: Channel 0 enables feedback, standard output, and	7		7	Y12: Channel 1 enables feedback, standard output, and

XF-E2HSP				
meaning	A terminal	terminal arrangement	B terminal	meaning
PWM output				PWM output
24V	8		8	0V



- The two S/S are internally isolated and not short-circuited.
- NPN: The S/S terminal is 24V, while the X terminal is 0V.
- PNP: The S/S terminal is 0V, while the X terminal is 24V.
- The pulse output has a maximum frequency of 200KHz. For applications requiring higher output frequencies, connect a 500Ω resistor between the output and the 24V power supply.

2) External wiring

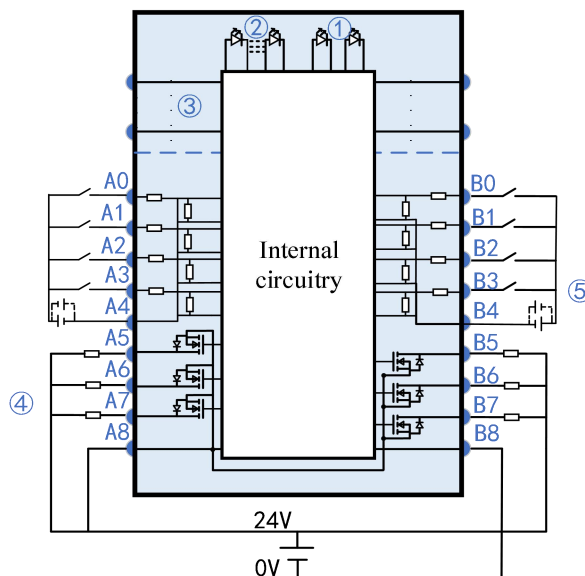

- ① System Indicator Light
- ② Channel indicator light
- ③ backplane bus
- ④ Output channel & wiring light
- ⑤ Input channel & wiring

11.2.5.3 Installation Method

1) Installation requirements

The module is mounted using DIN rails, which must comply with the IEC60715 standard (35mm wide, 1mm thick). The dimensions are shown in the figure below, with measurements in millimeters.

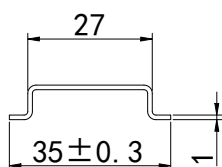

Attention

When the module is installed on a DIN rail not recommended above, the DIN rail latch may fail to lock properly.

2) Installation Steps

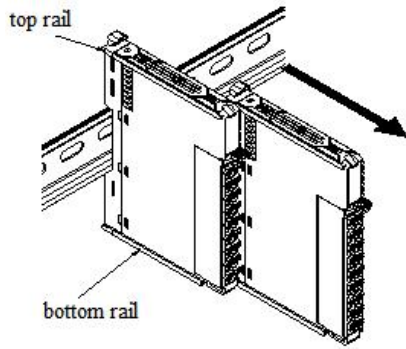

1. The IO modules are assembled by sliding along the top and bottom rails, as shown in the left figure.

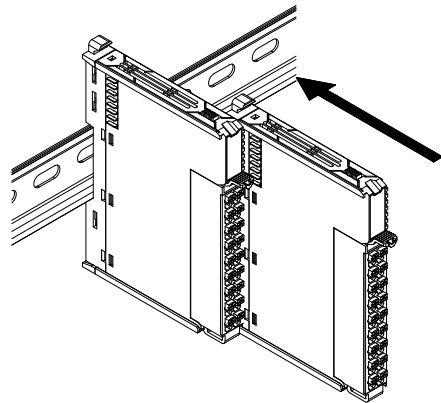

2. The module is mounted on the guide rail. During installation, align the module with the DIN guide rail and press it in the direction indicated by the arrow. A clear click sound will be heard when the module is properly secured, as shown in the left image.

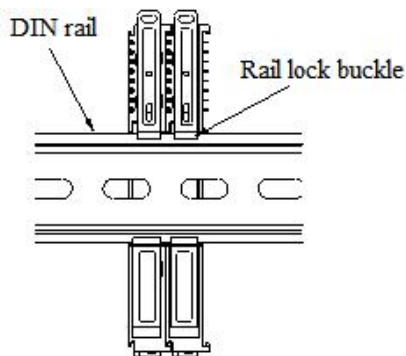

Note: After module installation, the latch will automatically move downward to lock. If it doesn't move, press the top of the latch downward to ensure proper installation.

3) Disassembly steps

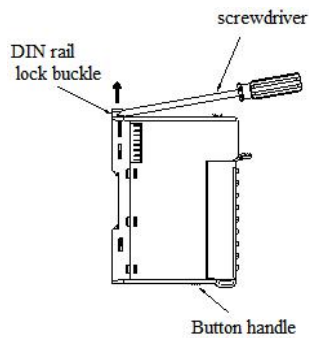

1. Use a screwdriver or similar tool to pry up the guide rail lock, as shown in the left image:

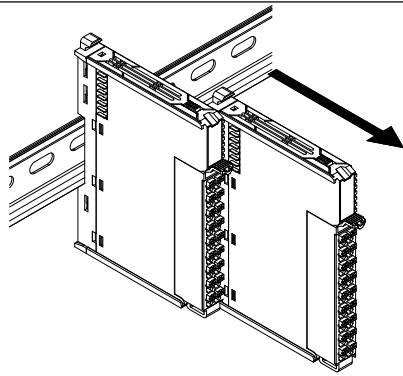

2. Pull the module straight forward from the buckle position (the raised part), then press down the top of the buckle as shown in the left image.

11.2.5.4 Installation Environment

This product supports four installation orientations: horizontal, vertical, top-mounted on electrical cabinets, and bottom-mounted. Horizontal installation is recommended. The cooling system utilizes natural convection. To ensure proper ventilation and heat dissipation while maintaining sufficient wiring clearance, a minimum clearance must be maintained around the product, as shown in the figure below.

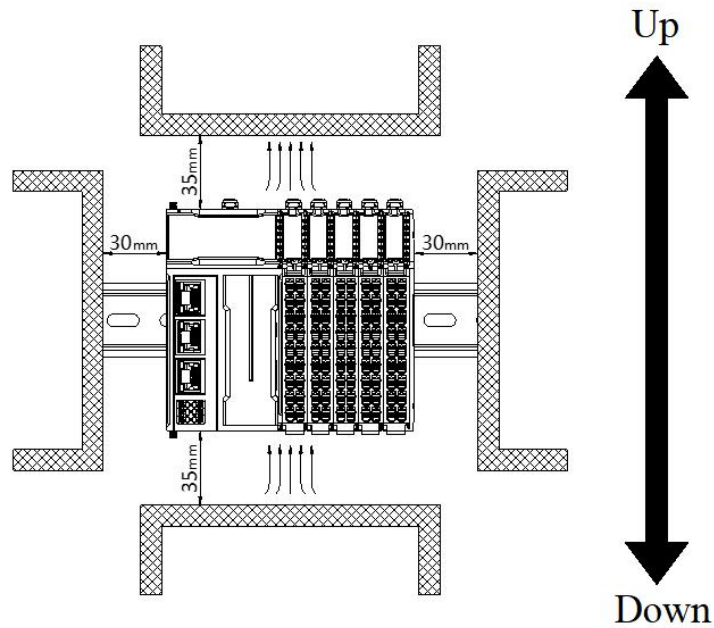

If the product is surrounded by high-temperature heat source equipment (heaters, transformers, high-resistance components, etc.), maintain a minimum clearance of 100mm between the product and such equipment.

11.2.5.5 Equipment Wiring

When wiring the module, the connectors must meet the following requirements:

Suitable wire gauge	
National standard/mm ²	American-Standard /AWG
0.3	22
0.5	20
0.75	18
1.0	18
1.5	16

If using other wire-type terminal lugs, press them onto the stranded wire as shown in the figure below for shape and size requirements.

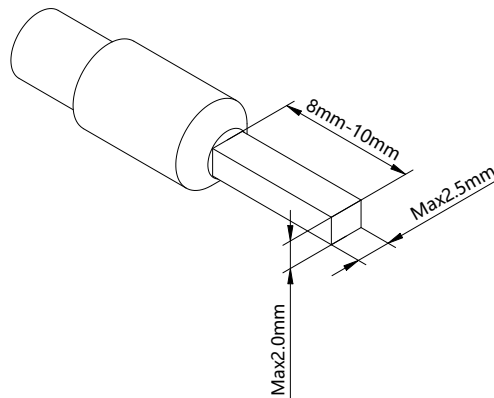

11.2.6 Configuration Module

To add the right expansion module: First, double-click the expansion module in the 'CPU Architecture' section. Then, in the 'Insert Body Expansion Module' dialog box that appears, select 'XF-E2HSP' to add the module. After addition, two axis variable instances ('HSP_Axis' and 'HSP_Axis_1') will automatically be created in 'SoftMotionGeneralAxisPool'.

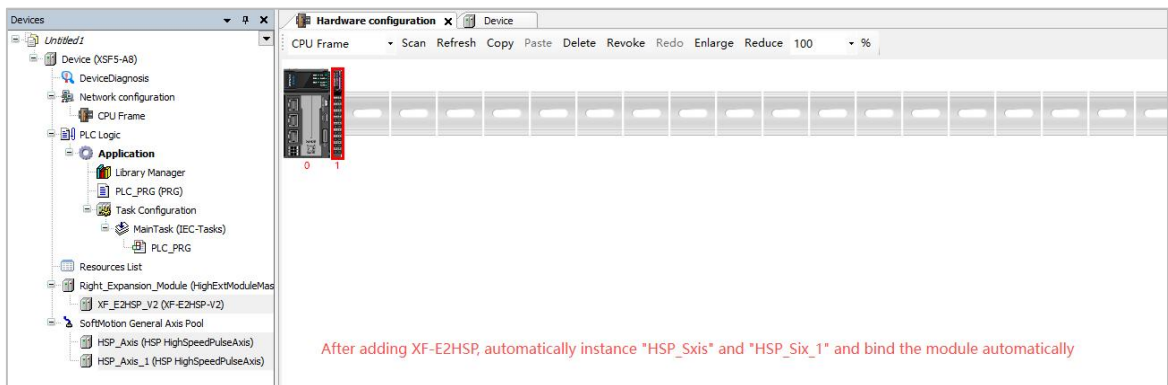
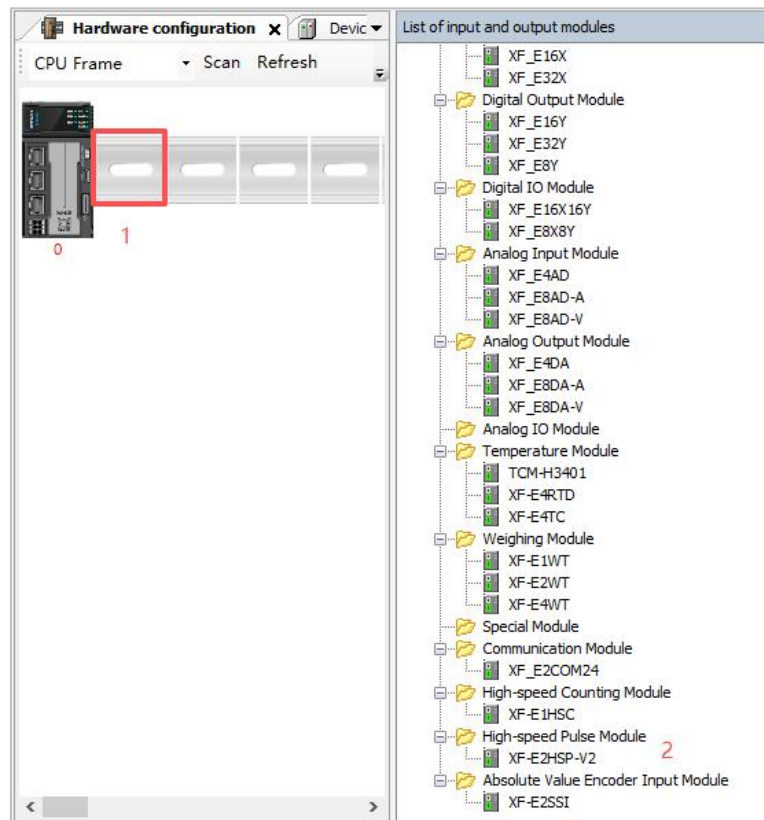

The IO mapping of Right_Expand_Module, the IO mapping of HSP_Axis, and the POU for the axis command of HSP_AXIS must all operate within the same task.

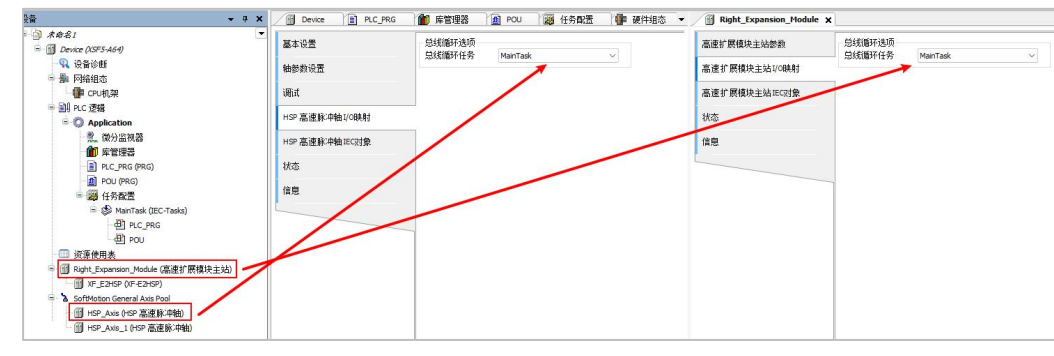

11.2.7 Functions and Settings

11.2.7.1 Regular Settings

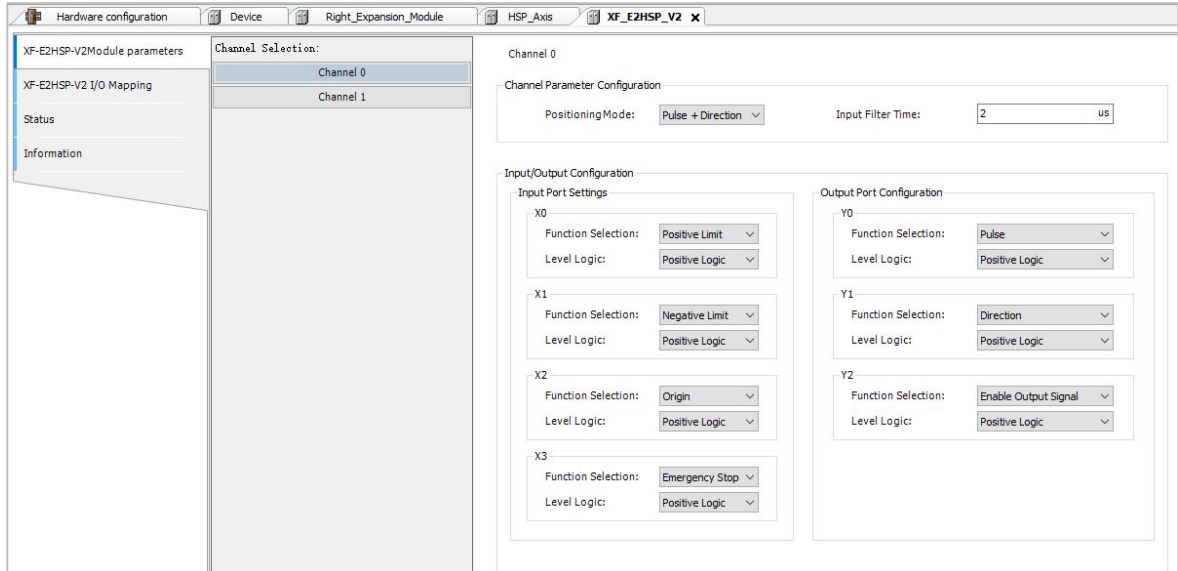

parameter	default setting	Explanation
positioning mode	pulse + direction	0: Pulse + direction 1: AB phase 2: CW/CCW
Input filter time	2us	When a signal is present at the input terminal and its duration exceeds the filter time, it is considered a valid signal. Range: 0-65535us
X0 function selection	positive limit	positive limit Standard Input
X1 feature selection	negative limit	negative limit Standard Input
X2 feature selection	origin	origin Standard Input
X3 feature selection	jerk	jerk Standard Input
X0-X3 level logic	positive logic	positive logic negative logic
Y0 function selection	impulse	pulsing signal common output signal
Y1 function selection	direction	directional signal common output signal
Y2 function selection	enable output signal	enable output signal common output signal PWM output

parameter	default setting	Explanation
Y0-Y2 level logic	positive logic	positive logic negative logic

11.2.7.2 Pulse Axis Parameter Settings

After adding the "XF_E2HSP" module, the "HSP_Axis" and "HSP_Axis_1" axis variable instances in the "SoftMotionGeneralAxisPool" can be configured with axis parameters.

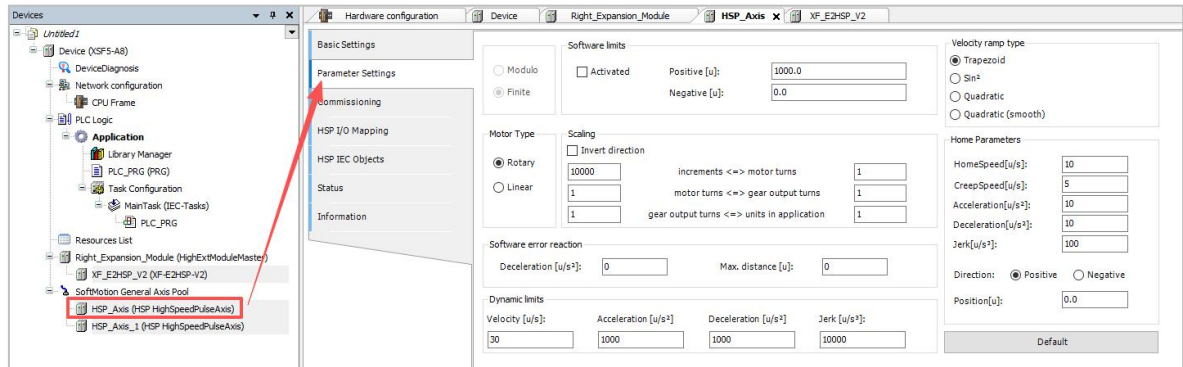

- Software limit: Positive limit (default 1000.0), Negative limit (default 0.0). The input range is of the LREAL type, and the negative limit must be less than or equal to the positive limit.
- Modulus value: The modulus value must be greater than 0.
- Zero-return parameter: This LREAL-type parameter specifies the zero-return speed, crawling speed, zero-return acceleration, zero-return deceleration, and zero-return double acceleration. The input range is (0, the maximum value of LREAL type), and the zero position is defined within the LREAL type range.

11.2.7.3 Instruction Introduction

1) Single-axis instruction

Command name	function declaration
MC_Power	Set the axis to an operational state
MC_Reset	Internal correlation error in the axis of reset
MC_Stop	Stop controller movement
MC_Halt	Pause the execution of the running function block
MC_Jog	crawl
MC_MoveAbsolute	Set a control axis to a specified absolute position
MC_MoveAdditive	Move an additional distance at the given speed and acceleration
MC_MoveRelative	Move the axis by a relative position from its current position
MC_MoveSuperImposed	Add a speed and acceleration run to the previous movement to cover an additional distance
MC_MoveVelocity	The axis runs continuously at a specified speed
MC_PositionProfile	time-space planning and execution

Command name	function declaration
MC_VelocityProfile	time velocity planning execution
MC_AccelerationProfile	time-acceleration planning execution
MC_ReadActualPosition	Read the current position of the relevant axis
MC_ReadActualTorque	Read the current torque of the relevant axis
MC_ReadActualVlocity	Read the current speed of the current axis
MC_ReadAxisError	Invalid code
MC_ReadBoolParameter	Get parameter values by parameter index
MC_ReadParameter	Get parameter value by parameter ID
SMC_ReadSetPosition	Read the current axis setting position
SMC_ReadFBError	Read the history of error messages for the function block
MC_WriteBoolParameter	Modify the parameter value of a specific Boolean variable specified by the user
MC_WriteParameter	Modify the user-specified special parameters
SMC_ClearFBError	Clear the history of block errors
SMC_ErrorString	Read the error description for this error code
SMC3_ReinitDrive	Reboot the drive or axis
SMC3_ETC_WriteParameter_CoE	Set the axis COE parameters
MC_TouchProbe	probe instruction
XMC_FERRCOMP	single axis accuracy compensation
XMC_ZRN	back to the origin

The MC_Home instruction is not supported in the return instruction. Use the XMC_ZRN instruction instead. XMC_ZRN is an instruction in the XJ_HLIO library (supported by firmware V2.2.0 and above on the lower-level machine), while the others are from the SM3_Basic library. For detailed instructions, refer to the "XS Series PLCopen Standard Controller User Manual [Motion Control Section]".

2) Axis Group Instructions

Command name	function declaration
MC_AddAxisToGroup	Add axis to axis group
MC_RemoveAxisFromGroup	Remove an axis from the axis group
MC_UngroupAllAxes	Delete all axes from the axis group
MC_GroupEnable	Enable axis group
MC_GroupDisable	Cancel axis group
MC_GroupReset	axial group reduction
MC_GroupSetPosition	Set axis group position
MC_SetCoordinateTransform	coordinate transformation
MC_SetDynCoordTransform	two shaft sets of a machine
MC_GroupContinue	Continue Axis Group
MC_GroupHalt	axial arrest
MC_GroupInterrupt	axial interruption
MC_GroupStop	axial arrest
MC_GroupSetOverride	Change speed, acceleration, or active and controlled actions
MC_SetKinTransform	motion coordinate system transformation

Command name	function declaration
MC_MoveCircularAbsolute	circular motion to absolute position
MC_MoveCircularRelative	Circular motion to relative position
MC_MoveDirectAbsolute	Move to absolute position
MC_MoveDirectRelative	Move to relative position
MC_MoveLinearAbsolute	Linear motion to absolute position
MC_MoveLinearRelative	Linear motion to relative position
MC_GroupReadActualPosition	Read actual position
MC_GroupReadActualVelocity	Actual speed reading
MC_GroupReadConfiguration	Read parameters
MC_GroupReadError	read error
MC_GroupReadStatus	Read status
SMC_StartupAxisGroup	starter shaft
SMC_GroupPower	axial group enabling
SMC_GroupInterruptAt	Break at specified
SMC_GroupEnableResumeAfterError	axis error recovery motion
SMC_GroupJog	axis group point motion
SMC_GroupWait	Axis group wait

All the instructions mentioned above are from the SM3_Basic library. For detailed instructions, refer to the user manual of the XS series PLCopen standard controller (Motion Control Chapter).

11.2.8 Application Examples

11.2.8.1 Applications of Single-Axis Functions

1. Install the XSF5-A64 right expansion XF-E2HSP module in the CPU rack. After adding the module, configure the pulse axis parameters in the generated axis instance HSP_Axis using the default settings.

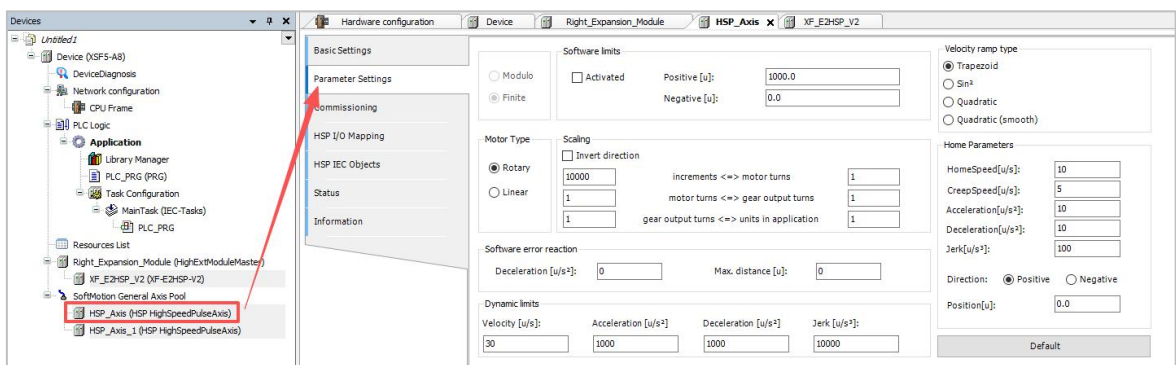

2. Write a program:

Use commands like [MC_POWER] and [MC_JOG] to control pulse-axis positioning, speed parameters, and axis status. The configuration is shown in the figure below.

The axis name parameter in the command is the name of the axis instance HSP_Axis.

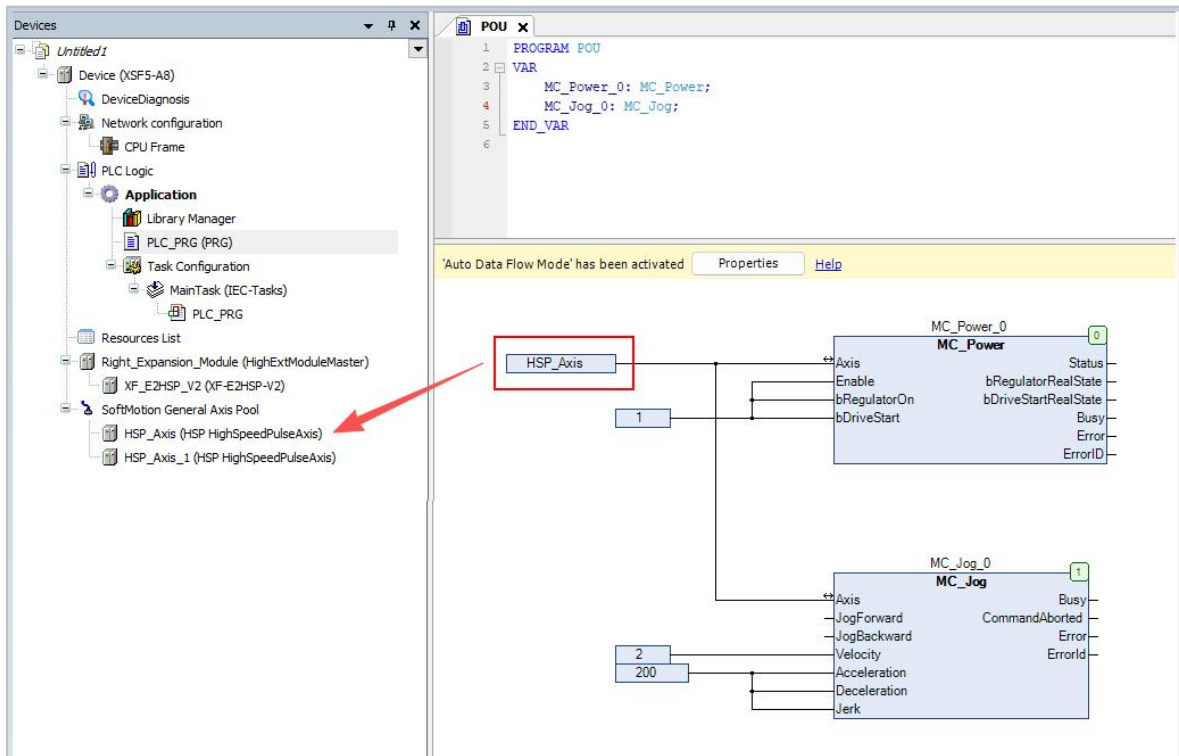

3. The command execution results are as follows:

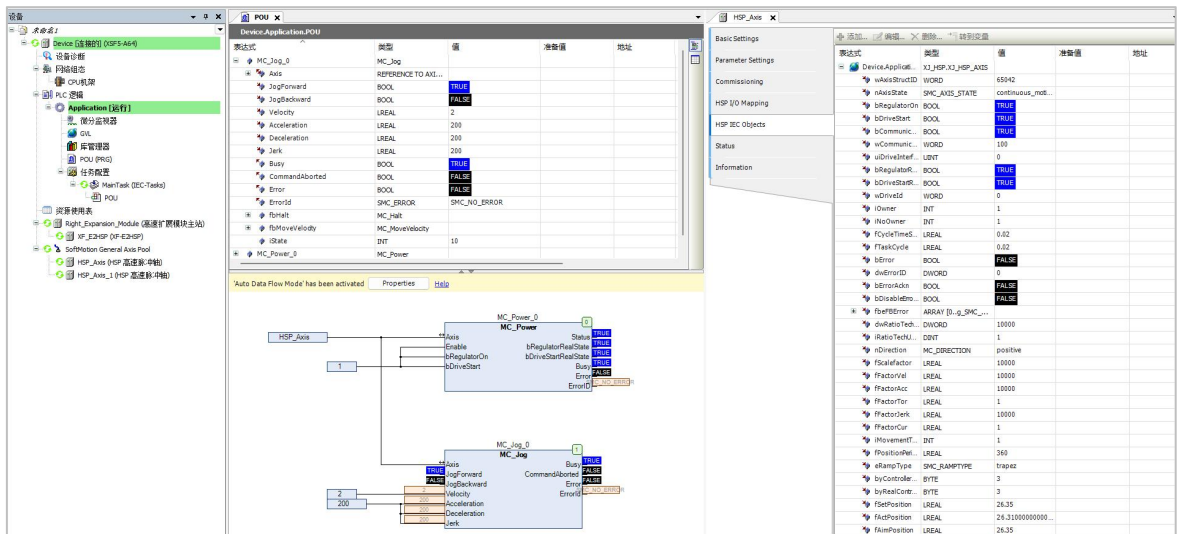

11.2.8.2 Axis Group Function Applications

1. Install the XSF5-A64 right expansion XF-E2HSP module in the CPU rack. After adding the module configuration, configure the pulse axis parameters in the generated axis instances HSP_Axis and HSP_Axis_1 using the default settings.

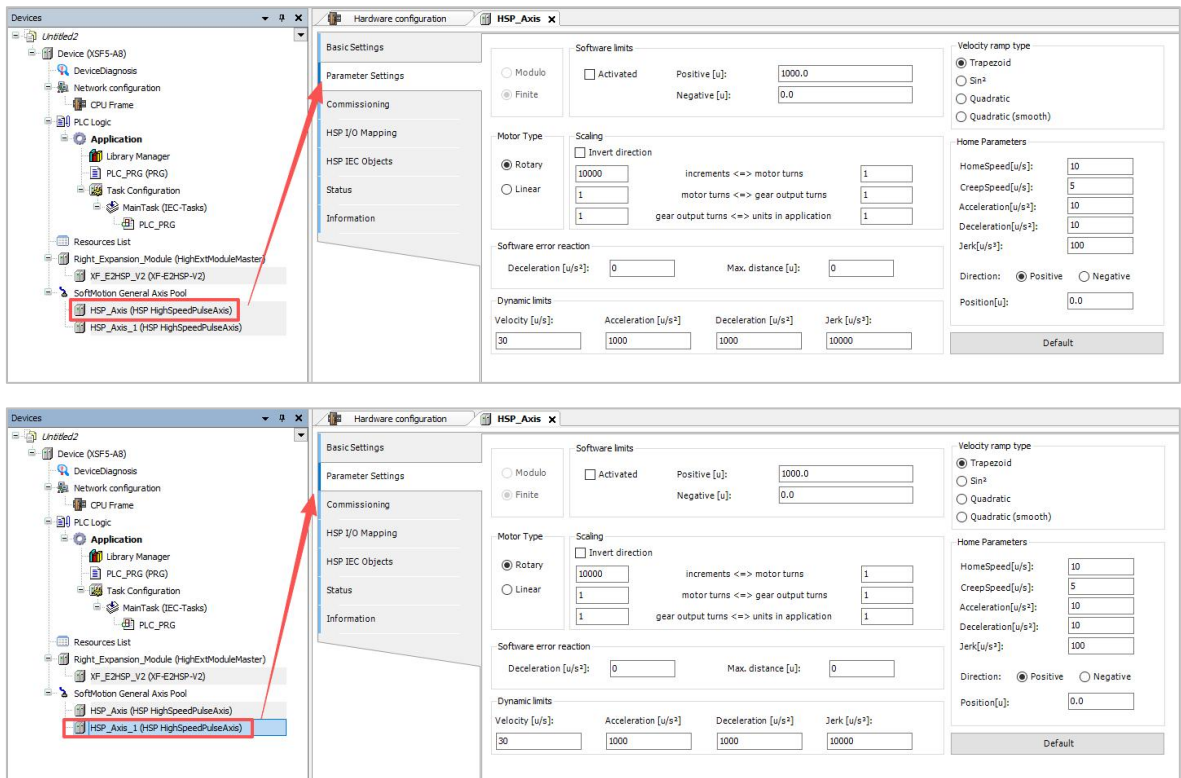

2. Add the axis group configuration in the Application, select the axis group model as TRAFO.Kin_Gantry2, and configure the two single axes of the axis group as HSP_Axis and HSP_Axis_1.

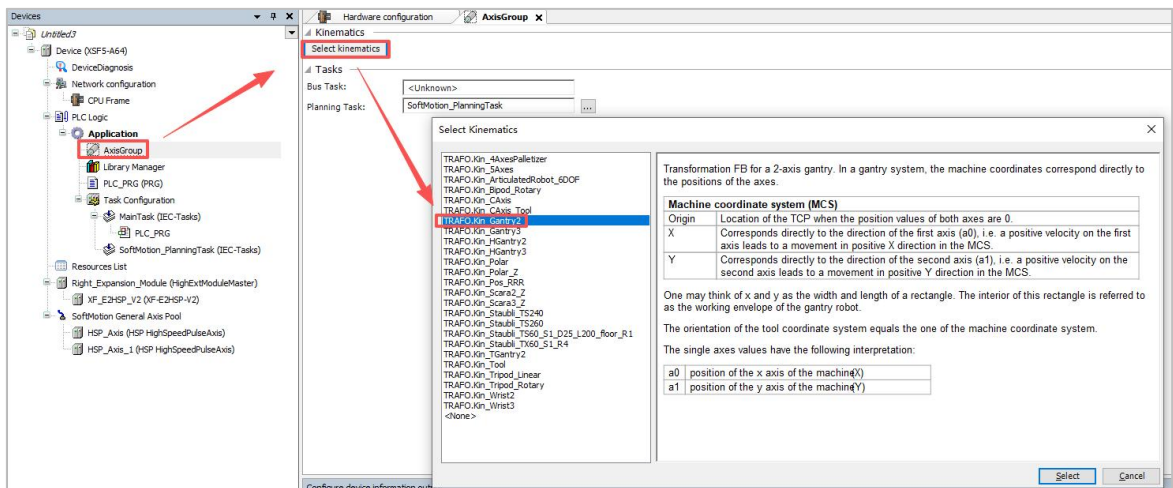
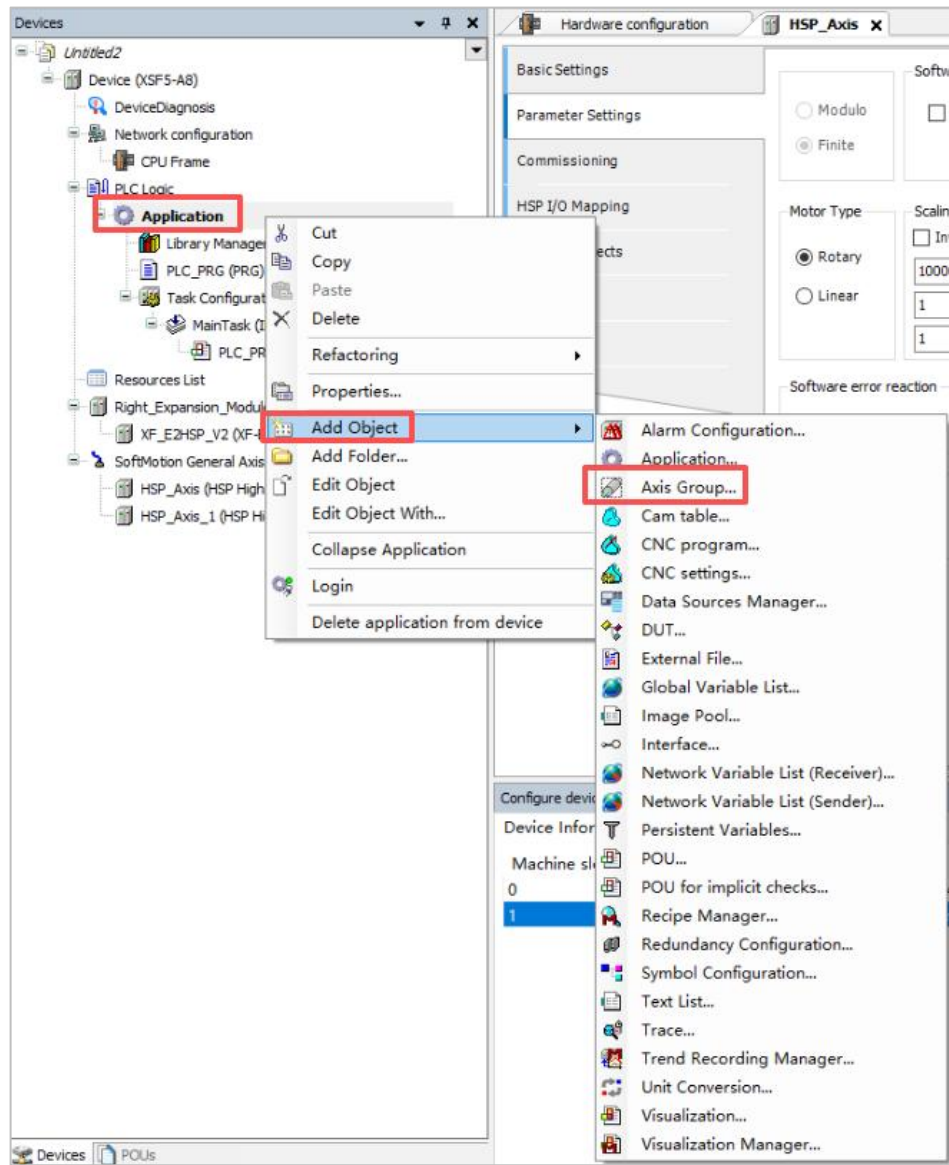

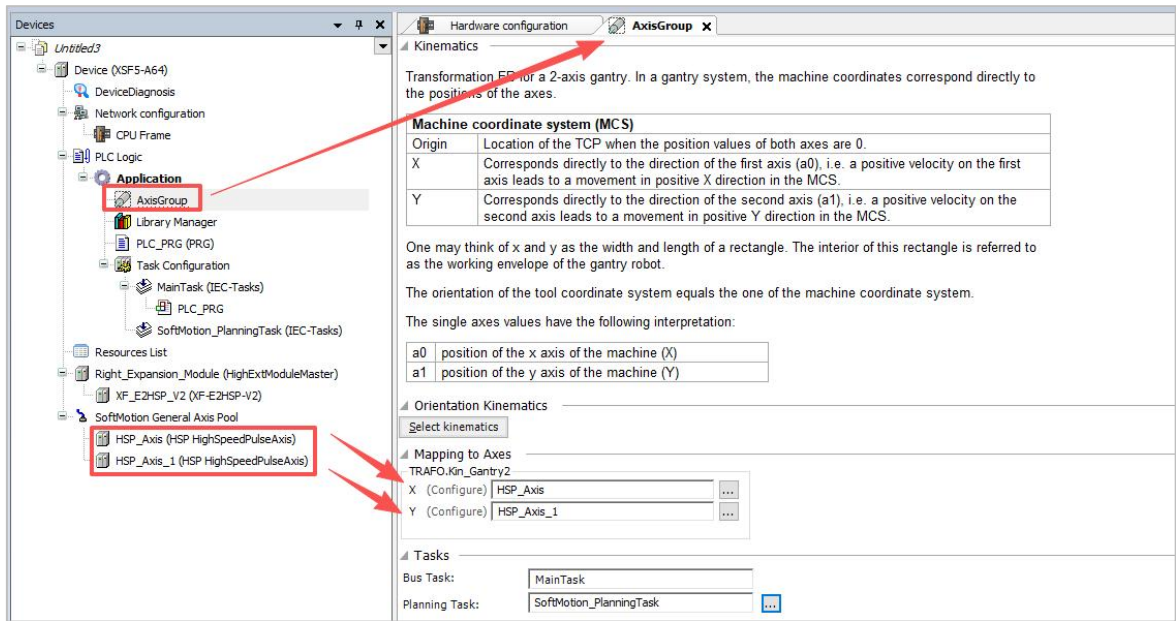

3. Write a program:

Use commands like [MC_GroupEnable], [SMC_GroupPower], and [MC_MoveLinearAbsolute] to enable absolute position motion for linear interpolation in pulse-axis groups, as shown in the configuration diagram below.

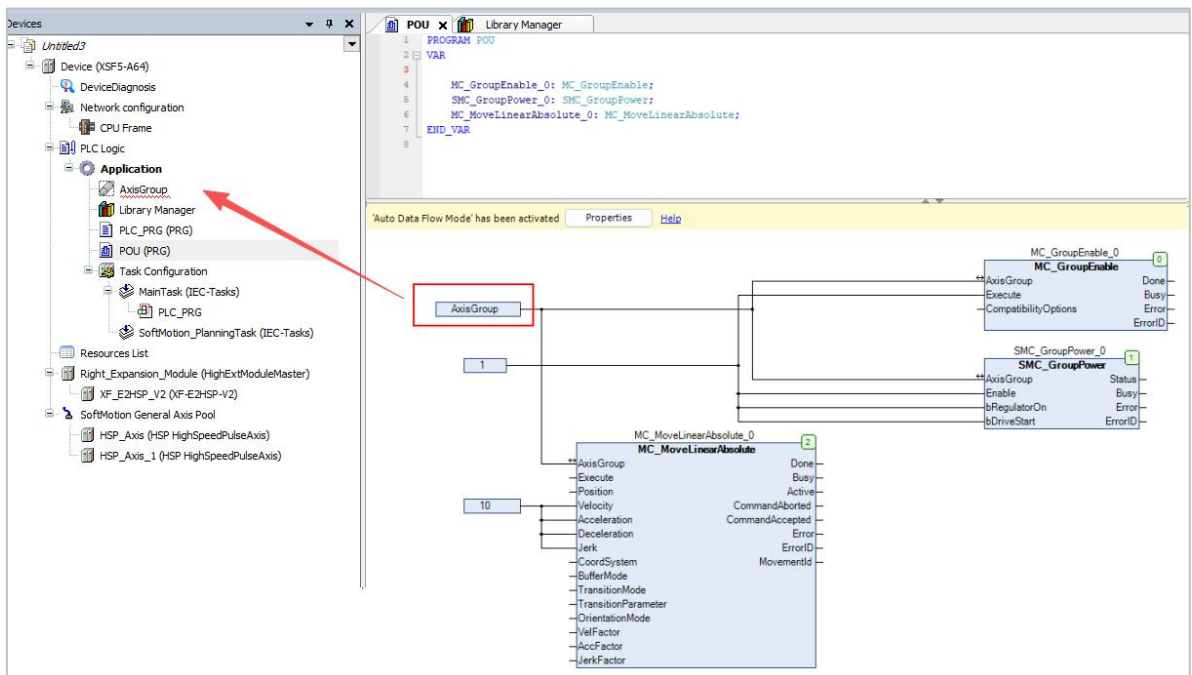

4. The command execution results are as follows:

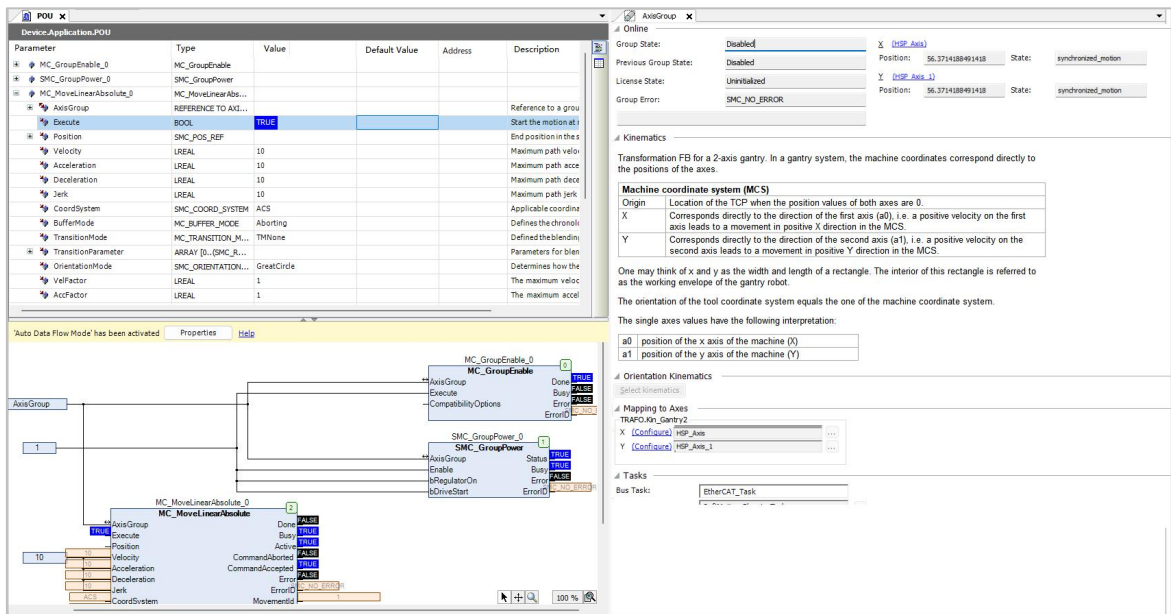

11.2.8.3 Applications of PWM Function

1. Install the XSF5-A8 right expansion XF-E2HSP module in the CPU rack. After adding the module configuration, configure the pulse axis parameters in the generated axis instances HSP_Axis and HSP_Axis_1 using default settings.

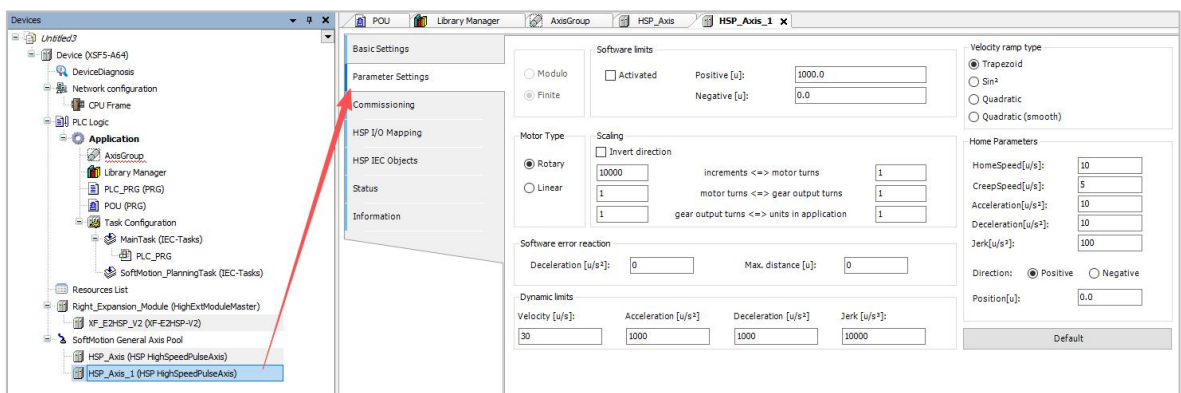
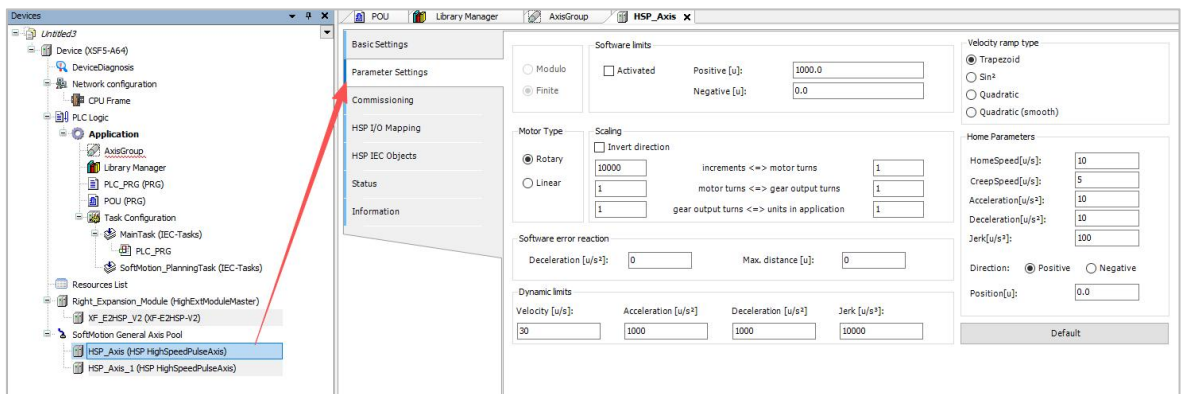

2. In the XF-E2HSP module parameters, configure channel 0's Y2 to PWM output.

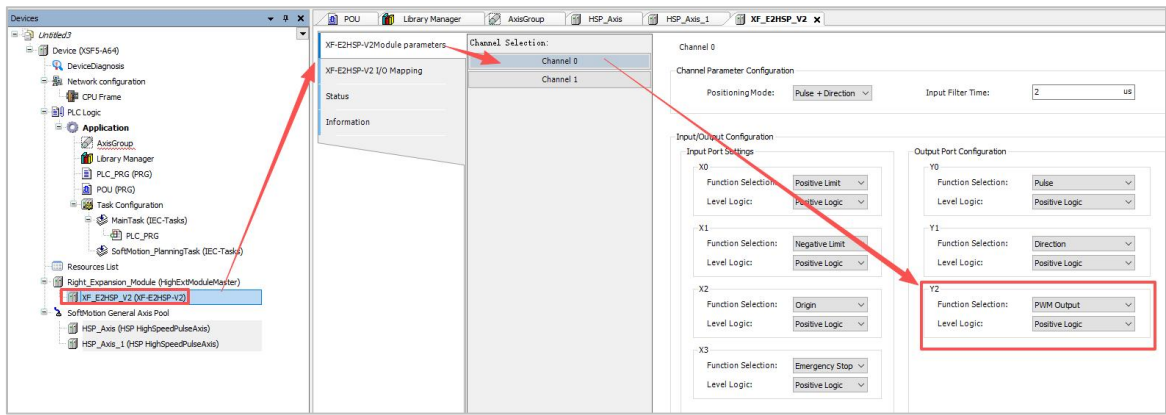

3. Program implementation: Add PWM commands to the program and connect them to the HSP_Axis pins.

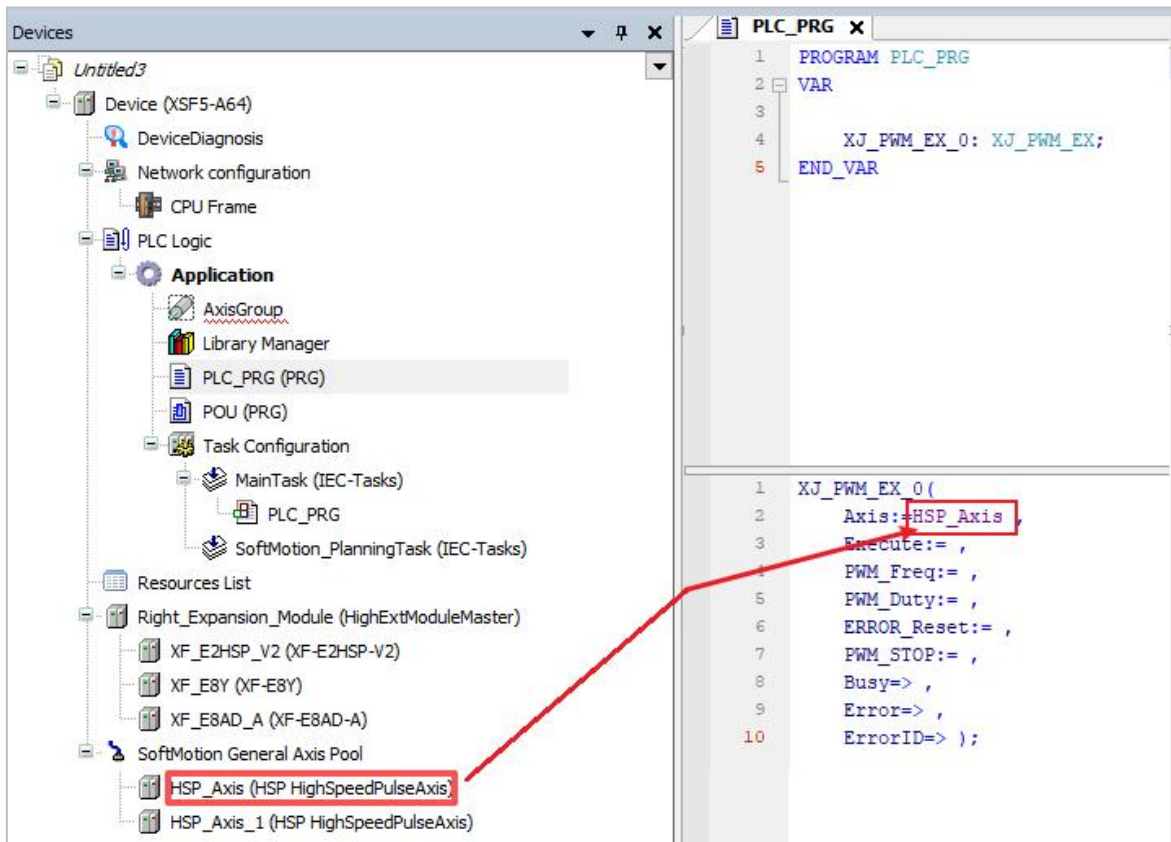

4. The instruction executes as follows: Set the output frequency to 1 and the duty cycle to 32767. When this instruction is executed, Y2 will flash according to the set parameters and generate PWM output.

PLC_PRG x

Device.Application.PLC_PRG

Parameter	Type	Value	Default Value	Address	Description
XJ_PWM_EX_0	XJ_PWM_EX				
Axis	REFERENCE TO XJ_...				Axis
Execute	BOOL	TRUE			Rising edge active
PWM_Freq	UINT	1			
PWM_Duty	UDINT	32767			
ERROR_Reset	BOOL	FALSE			Rising edge active
PWM_STOP	BOOL	FALSE			Rising edge active
Busy	BOOL	TRUE			Busy state
Error	BOOL	FALSE			Error state
ErrorID	PWM_ERROR	NO_ERROR			Error code
PWM_STATE	PWM_INSTATE	PWM_RUN			
PrevExecute	BOOL	TRUE			
Active	BOOL	TRUE			
PrevStop	BOOL	FALSE			
PrevReset	BOOL	FALSE			

```

1 XJ_PWM_EX_0(
2   Axis:=HSP_Axis ,
3   Execute:= ,
4   PWM_Freq:= ,
5   PWM_Duty:= ,
6   ERROR_Reset:= ,
7   PWM_STOP:= ,
8   Busy=> ,
9   Error=> ,
10  ErrorID=> );RETURN
    
```

12. Frequently Asked Questions

Q1: After power-on, the PWR indicator on the module flashes at 1Hz.

A1: Check if the current module is receiving a stable DC24V power supply.

Manual update log

The data number of this manual is recorded in the lower right corner of the manual cover.

Time	Document ID	Change content
2023.9	PF 02 20230906 1.0	The first edition of the manual was published.
2023.12	PF 02 20231204 1.1	<ol style="list-style-type: none">1. Update the error code parameter table;2. Add a configuration parameter table;3. Chapter 7: Frequently Asked Questions has been added.
2024.4	PF 02 20240406 1.1.1	Update the external wiring diagrams for XF-E4AD and XF-E4DA.
2024.5	PF 02 20240508 1.1.2	The documentation for the XF-E16PYT module has been updated.
2024.6	PF 02 20240722 1.2	New documentation has been added for the XF-E2COM24, XF-E4RTD, and XF-E4TC modules.
2024.11	PF 02 20241118 1.3	New documentation has been added for the XF-E1HSC, XF-E32X, XF-E32YT, and XF-E16X16YT modules.
2025.1	PF 02 20250103 1.3.1	Manual error correction.
2025.4	PF 02 20250409 1.4	<ol style="list-style-type: none">1. Add chapter 10;2. Modify the content of section 8.3.8;3. Other errors were corrected.
2025.5	PF 02 20250519 1.4.1	<ol style="list-style-type: none">1. Adjust the configuration parameter range in Section 6.3.6.2. Other errors were corrected.
2025.7	PF 02 20250827 1.5	New documentation for XF-EP24 and XF-E8YR modules has been added.



Scan the WeChat QR code
to follow us

XINJE

WUXI XINJE ELECTRIC CO., LTD.

Address: No. 816, Jianxi West Road, Binhu District, Wuxi City, Jiangsu Province

WhatsApp:+86 180 6833 9655

Website: <https://en.xinje.com/web/index>

Email:

sales@xinje.com

tech@xinje.com