



## DM6C Series All-in-One Servo Drive

Precision Intelligent Control • Powerful Performance •  
The Choice for Quality Compatible | with 0.4-75KW  
MS6 CN/TH Motor

Automation Trusted Partner



XINJE WeChat

XINJE

WUXI XINJE ELECTRIC CO.,LTD.

Address: No.816,Jianzhu West Road,Binhu District,Wuxi City,Jiangsu Province,China

TEL: 86-0510-85134136

Fax: 86-0510-85111290

Website: www.xinje.com

Email: sales@xinje.com

Technical Service Hotline  
**400-885-0136**

# COMPANY INTRODUCTION

Wuxi XINJE Electric Co., Ltd. (XINJE) is a well-known domestic enterprise focused on the R&D and application of industrial automation products.

Since its establishment, the company has adhered to the principle of "Independent Innovation, Swift and Pragmatism", continuously enhancing its R&D capabilities, product quality, and corporate strength by leveraging the latest technological achievements. Through persistent innovation and proactive development, XINJE has remained at the forefront of the industry. It has been recognized as a National High-Tech Enterprise, Jiangsu Provincial Private Sci-Tech Enterprise, Jiangsu Provincial Sci-Tech SME, and included in the Sci-Tech Enterprise Listing Cultivation Program. It is also a key project unit under the "Six Major Actions for a Strong Industrial Province" initiative, a qualified unit for intellectual property standardization in Jiangsu, and has established provincial-level engineering research centers, corporate technology centers, and engineering centers. The company holds numerous patented technologies and several industry-first core technologies.

XINJE's core products include Programmable Logic Controllers (PLCs), Human-Machine Interfaces (HMIs), servo control systems, and frequency conversion drives. It also offers cutting-edge products such as intelligent machine vision systems, teach-pendant-based robotic arms, and robots, along with comprehensive automation equipment integrated with information networks. These solutions closely serve end customers, providing competitive industry-specific solutions for equipment manufacturing enterprises and delivering advanced and reliable automation products to high-quality device manufacturers. The company continuously helps businesses enhance productivity, reduce costs, maximize profits, and foster mutual growth of corporate and customer value.

To date, XINJE has established 32 domestic offices and 300 distributors across China, ensuring nationwide coverage. Internationally, it operates one subsidiary and 20 agents covering Europe, the Americas, Southeast Asia, the Middle East, and Africa. This extensive sales network guarantees comprehensive automation product needs, technical support, and personnel training services for users worldwide. The company currently employs over 2,200 staff and boasts a 20,000-square-meter office building, multiple independent factories spanning 71,000 square meters, one R&D center, four laboratories, and 86 training bases. XINJE also collaborates with numerous universities to cultivate young and talented technical professionals.

With a dedicated and sincere approach, an enterprising team spirit, and efficient execution, XINJE has achieved remarkable accomplishments. In December 2016, it successfully listed on the Main Board of the Shanghai Stock Exchange (Stock Code: 603416). Upholding the business philosophy of "Innovation, Quality, Service," the company continues to develop more reliable products, improve quality, and strives to become a "world-class provider of intelligent and automated integrated solutions," building an enduring golden reputation in the industrial automation sector.

32

Offices

300

Domestic Distributors

2200+

Number of Employees

20000+

Office Building Floor Area

71000+

Total Floor Area of Multiple Independent Factories

## Pain Points in High-Power Applications

### 01 Frequent Failures and Low Reliability

Due to complex on-site environments and lack of experience in safety function application, equipment instability and insufficient reliability may occur, leading to frequent safety incidents.

Encoder failures

Overcurrent, overload, overvoltage



### 02 Difficult Installation and Troublesome Debugging

As power ratings increase, servo drives become larger in size, raising installation challenges and prolonging installation time. In large-scale equipment applications, the wiring and debugging of drive systems consume significant labor costs.

### 03 High Energy Consumption and Costs

Traditional single-axis high-power servo systems often exhibit high energy losses in most scenarios. For example, during deceleration, excess braking energy generated by the motor can only be dissipated through regenerative resistors.

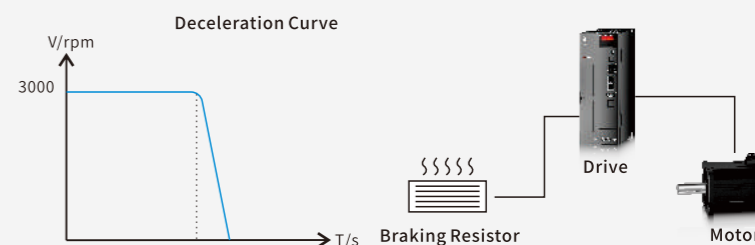

### 04 Harsh Environments and Poor Protection

High-power servos are typically used in harsh environments. Drives without enhanced protection frequently trigger fault alarms when exposed to vibrations, impacts, oil, moisture, dust, salt spray, cotton fibers, and similar conditions.

### 05 Average Performance and Low Efficiency

With the advancement of industrial automation, equipment demands for control precision and responsiveness in servo CNC systems are increasingly stringent. Existing servo systems often fail to meet the requirements for high-precision and high-efficiency machining in modern equipment.



# Core Advantages

## 01 Safety and Reliability

### STO Function as Standard

- ◆ Supports Safe Torque Off (STO). When the safety torque function is activated, the drive's internal hardware circuit triggers, forcibly shutting down the drive's power transistors to halt motor operation, ensuring personnel and equipment safety.

### 24V Control Power Independent Supply

- ◆ The panel supports independent 24V control power supply, enabling communication with the host computer even when the main circuit is not powered.

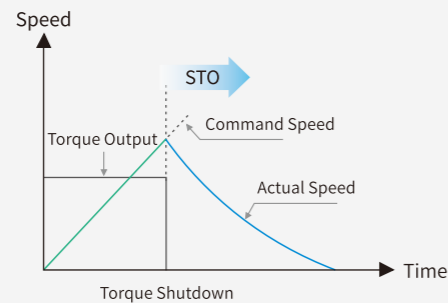

## 02 Space Saving, Convenient Wiring, Flexible Configuration

- ◆ Book-style modular design with equal height and depth, allowing compact side-by-side installation within limited space, significantly improving cabinet utilization.
- ◆ Only one set of power lines required. Internal reliable connection between modules is achieved via common busbar using copper bars and screw locking.
- ◆ Inverter modules below 15KW adopt plug-in power terminals, saving approximately 30% of wiring labor time.

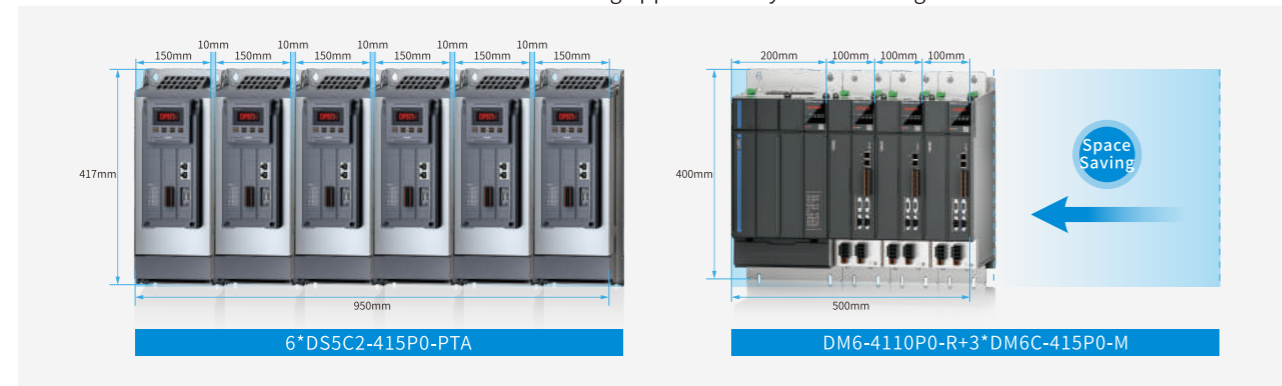

### Flexible Configuration

- ◆ Adopts a rectifier + inverter module combination. Taking a 110kW rectifier unit as an example, the following inverter module configurations are available:

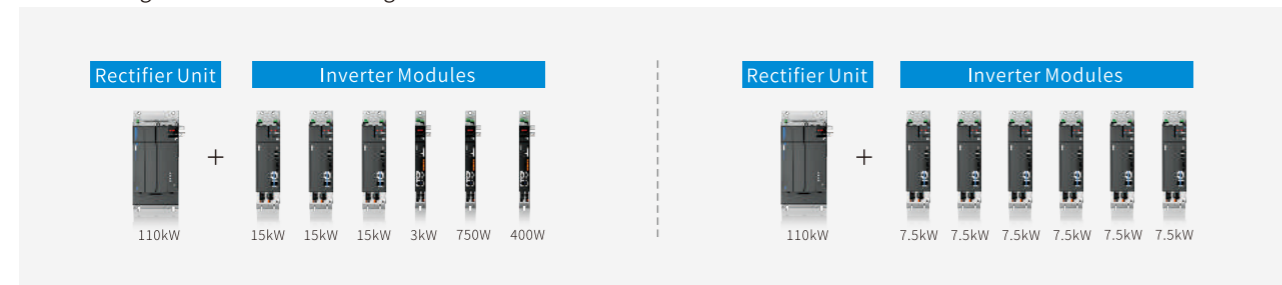

## 03 High Efficiency and Energy Savings

### Common DC Bus for Energy Conservation

- ◆ Utilizes common DC bus technology for energy interaction, reducing drive energy loss. Expected to save up to 30% in electricity consumption, delivering higher energy efficiency and performance.

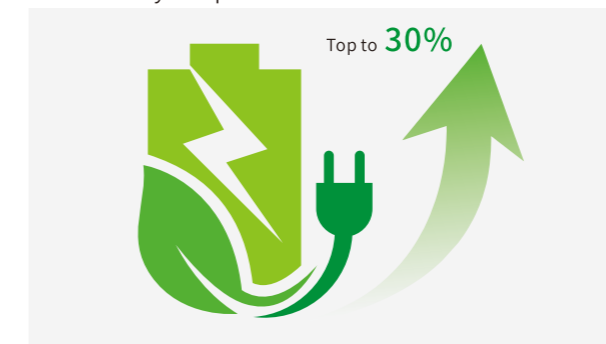

## 04 High Protection

- ◆ Independent Air Duct Design, Prevents dust or foreign particles from entering the control circuit.
- ◆ Enhanced Triple Protection, Improves the drive's resistance to harsh environmental conditions.



## 05 High Dynamic Response, Vibration Suppression, and Efficient Tuning

- ◆ 3kHz Speed Loop Response Bandwidth; 250μs Synchronization Cycle; high dynamic response enhances production efficiency.
- ◆ Advanced control algorithms provide optimal solutions for achieving both rapid and smooth positioning in high-speed systems.

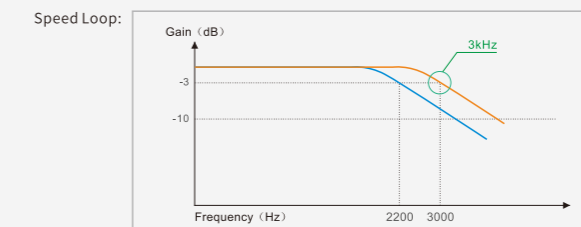

### Resonance Suppression

- ◆ Resonance damping control algorithms significantly reduce settling time and eliminate mechanical resonance, ensuring smooth and precise path tracking.
- ◆ Automatic Resonance Frequency Scanning improves usability.
- ◆ Vibration frequency identification accuracy improved by 50%.
- ◆ Resonance frequency analysis time reduced by 50%.

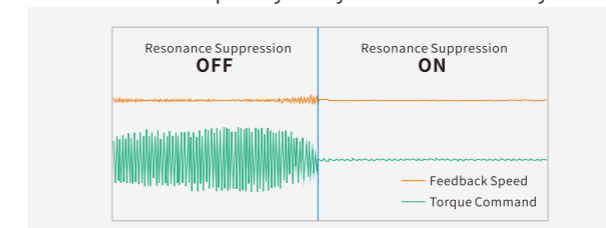

### End-Effector Vibration Suppression

- ◆ Advanced control algorithms suppress vibrations and noise at the mechanical end-effector. Effectively resolves cantilever mechanism tip vibrations, shortens settling time, and enhances product accuracy.

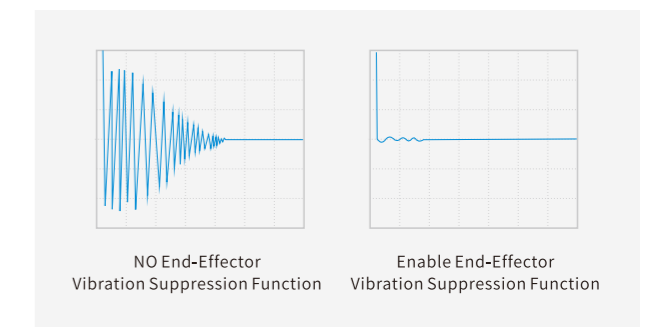

## Precision Alignment with High-End Manufacturing Industry, Leading the New Trend of Industrial Automation!

### 01 Laser Cutting

- ◆ X/Y positioning accuracy reaches  $\pm 0.03\text{mm}/1000\text{mm}$ . XY repeat positioning accuracy requirement is  $\pm 0.02\text{mm}$ ;
- ◆ In emergency situations, the motor output torque must be immediately cut off to achieve rapid shutdown;
- ◆ During unexpected shutdowns, a smooth stop must be maintained to enhance the service life of mechanical components;
- ◆ Limited installation space requires a compact and small-volume design.

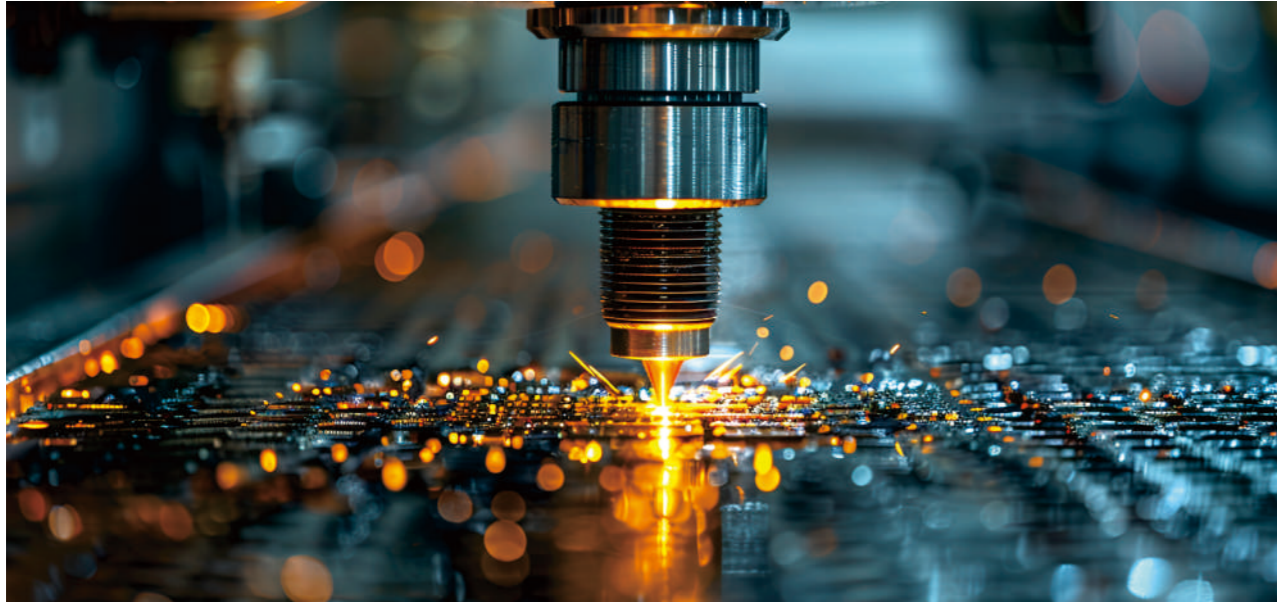

### 02 Precision Printing and Packaging

- ◆ Constant-speed printing accuracy reaches  $\pm 0.05\text{mm}$ ;
- ◆ Acceleration and deceleration accuracy reaches  $\pm 0.1\text{mm}$ , with a printing speed of  $150\text{m}/\text{min}$ ;
- ◆ The printing equipment operates in environments with significant oil stains and moisture, requiring servo drives to be waterproof and oil-resistant;
- ◆ Power outage must not cause paper breakage;
- ◆ Compact size to save installation space.



## Extreme Speed Operation, Unerring Precision Exceptional Stability, Enhanced Durability Boost Production Efficiency, Elevate Product Quality, Building the Foundation for Efficient and Intelligent Manufacturing!

### 03 Wire Cutting

- ◆ Wire speed reaches  $2000\text{m}/\text{min}$ , with pendulum fluctuation within 1 degree;
- ◆ The drive can operate reliably for extended periods in dusty environments;
- ◆ Maintains uninterrupted wire operation at 60% load and  $1800\text{m}/\text{min}$  wire speed during power outages.

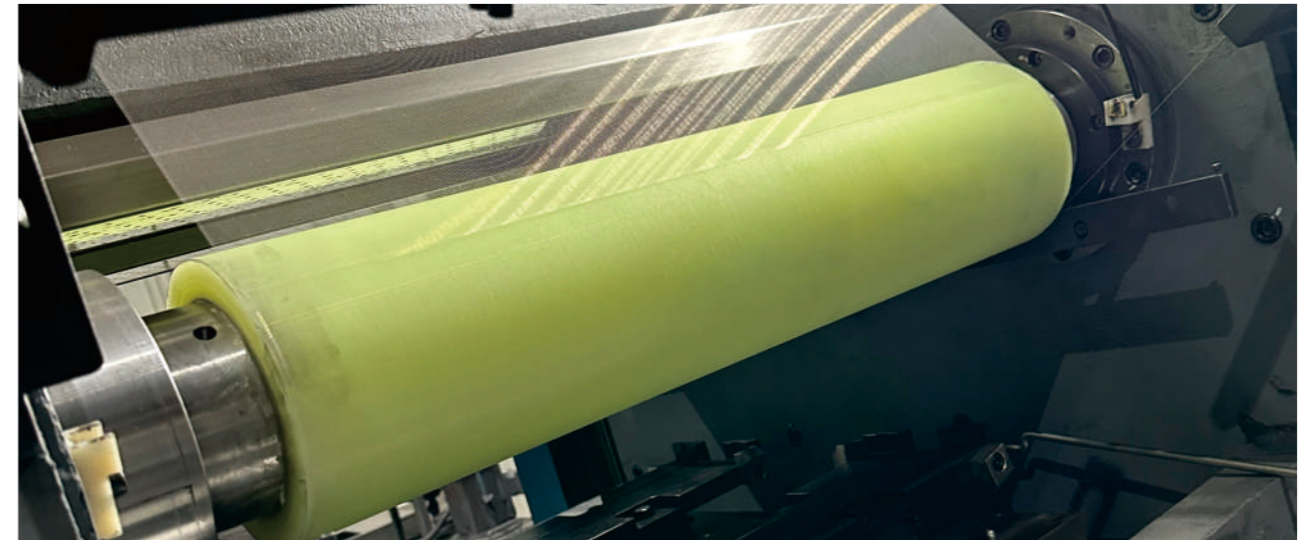

### 04 Forging Machine

- ◆ Speed ranges from 3200 to 4500 rpm;
- ◆ Positioning accuracy:  $\pm 0.05\text{mm}$  to  $0.1\text{mm}$ , repeat positioning accuracy:  $\pm 0.1\text{mm}$ ;
- ◆ Resistant to oil, corrosion, and capable of safe operation in metallic dust environments;
- ◆ Ensures immediate shutdown during power outages;
- ◆ Reduces energy consumption and emissions to achieve green production;
- ◆ Requires space-saving installation for cutting and bending equipment.



# Model Naming

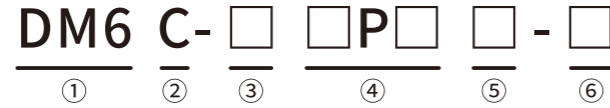

Number	Item	Content
①	Product Series	DM6: DM6 Series
②	Product Category	C: ETHERCAT Bus Type Default: Rectifier Unit, Braking Unit(default here)
③	Voltage Specification	4: AC380V
④	Drive Power	0P4: 400W 0P7: 750W 1P5: 1.5kW 3P0: 3kW 5P5: 5.5KW 7P5: 7.5kW 11P0: 11KW 15P0: 15kW 22P0: 22KW 32P0: 32kW 45P0: 45KW 55P0: 55kW 75P0: 75kW 110P0: 110kW 160P0: 160KW
⑤	Number of Inverter Axes	S: Single Axis Default: Dual Axis
⑥	Unit Category	R: Rectifier Unit M: Inverter Unit

# Model List

Power (kW)	Rated Output Current (A)	Rectifier Module
22.0	56	DM6-422P0-R (Under Development)
45.0	107	DM6-445P0-R (Under Development)
75.0	152	DM6-475P0-R (Under Development)
110.0	240	DM6-4110P0-R
160.0	358	DM6-4160P0-R (Under Development)

Power (kW)	Inverter Module	Axes num	Axis Pwr (Pwr*Num of Axes)	Rated Current(A)	Max Current(A)	Compatible Motor (Recommended)
0.4	DM6C-40P4-M	2	0.4*2	2.8	8.4	MS6S-60CN30B3-20P4
						MS6S-60CN30BZ3-20P4
						MS6S-60TH30B3-20P4
						MS6S-60TH30BZ3-20P4
						MS6H-60CN30B3-20P4
						MS6H-60CN30BZ3-20P4
						MS6H-60TH30B3-20P4
0.7	DM6C-40P7-M	2	0.75*2	4.8	14.4	MS6H-60TH30BZ3-20P4
						MS6S-80CN30B3-20P7
						MS6S-80CN30BZ3-20P7
						MS6S-80TH30B3-20P7
						MS6S-80TH30BZ3-20P7
						MS6H-80CN30B3-20P7
						MS6H-80TH30B3-20P7
1.5	DM6C-41P5-M	2	1.5*2	6	18	MS6G-110CN30B2-41P5
						MS6G-110CN30BZ2-41P5
						MS6G-110TH30B2-41P5
						MS6G-110TH30BZ2-41P5
						MS6G-130CN20B2-41P5
						MS6G-130CN20BZ2-41P5
						MS6G-130CN15B2-41P5
						MS6G-130CN15BZ2-41P5
						MS6G-130TH20B2-41P5
						MS6G-130TH20BZ2-41P5
						MS6G-130TH15B2-41P5
						MS6G-130TH15BZ2-41P5
						MS6G-130TH15B2-41P5
						MS6G-130TH15BZ2-41P5
						MS6G-130TH15B2-41P5
MS6G-130TH15BZ2-41P5						

Power (kW)	Inverter Module	Axes num	Axis Pwr (Pwr*Num of Axes)	Rated Current(A)	Max Current(A)	Compatible Motor (Recommended)
3.0	DM6C-43P0-M	2	3.0*2	11	29.7	MS6H-180CN15B2-43P0
						MS6H-180TH15BZ2-43P0
						MS6G-180CN15B2-43P0
						MS6G-180CN15BZ2-43P0
						MS6G-180TH15B2-43P0
						MS6G-180TH15BZ2-43P0
						MS6S-130CN30B2-43P0
						MS6S-130TH30B2-43P0
						MS6S-130CN30BZ2-43P0
						MS6S-130TH30BZ2-43P0
5.5	DM6C-45P5-M	2	5.5*2	20	50	MS6H-180CN15B2-44P4
						MS6H-180CN15BZ2-44P4
						MS6G-180CN15B2-44P4
						MS6G-180CN15BZ2-44P4
						MS6G-180TH15B2-44P4
						MS6G-180TH15BZ2-44P4
						MS6S-130CN30B2-45P0
						MS6S-130TH30B2-45P0
						MS6S-130CN30BZ2-45P0
						MS6S-130TH30BZ2-45P0
						MS6H-180CN15B2-45P5
						MS6H-180CN15BZ2-45P5
						MS6H-180CN15E2-45P5
						MS6H-180CN15EZ2-45P5
MS6G-180CN15B2-45P5						
MS6G-180CN15BZ2-45P5						
MS6G-180TH15B2-45P5						
MS6G-180TH15BZ2-45P5						
7.5	DM6C-47P5-M	2	7.5*2	25	62.5	MS6H-180CN15B2-47P5
						MS6H-180CN15BZ2-47P5
						MS6H-180CN15E2-47P5
						MS6H-180CN15EZ2-47P5
						MS6G-180CN15B2-47P5
						MS6G-180CN15BZ2-47P5
						MS6G-180TH15B2-47P5
						MS6G-180TH15BZ2-47P5
						MS6G-200TH17B2-417P0-F
						MS6G-200TH17B2-413P0-F
15.0	DM6C-415P0-M	2	15.0*2	37	77.7	MS6G-200TH17BZ2-417P0-F
						MS6G-200TH17BZ2-413P0-F
						MS6G-200TH17B2-417P0-Y
						MS6G-200TH17B2-413P0-Y
						MS6G-200TH30B2-422P0-YL01
						MS6G-200TH30B2-415P0-YL01
						MS6G-200TH17B2-421P0-F (UD)
						MS6G-200TH17BZ2-421P0-F (UD)
						MS6G-200TH17B2-421P0-Y (UD)
						MS6G-200TH17BZ2-421P0-Y (UD)
32.0	DM6C-432P0S-M (Under Development)	1	32.0*1	65	130	MS6G-200TH17B2-427P0-F (UD)
						MS6G-200TH17BZ2-427P0-F (UD)
						MS6G-200TH17B2-427P0-Y (UD)
45.0	DM6C-445P0S-M (UD)	1	45.0*1	100	250	MS6G-265TH17B2-430P0-F (UD)
						MS6G-265TH17B2-430P0-Y (UD)
55.0	DM6C-455P0S-M (UD)	1	55.0*1	126	315	MS6G-265TH17B2-448P0-F (UD)
						MS6G-265TH17B2-448P0-Y (UD)
75.0	DM6C-475P0S-M (UD)	1	75.0*1	152	380	MS6G-265TH20B2-456P0-Y01 (UD)
						MS6G-265TH17B2-460P0-F (UD)
						MS6G-265TH17B2-460P0-Y (UD)
						MS6G-265TH17B2-475P0-F (UD)
						MS6G-265TH17B2-475P0-Y (UD)

# Specification Parameters

Specifications		Model	Inverter Unit	
			<b>DM6C-M Series</b>	
Basic Specifications	Power Range(KW)		0.4KW-75KW	
	Input Power Supply		DC537V-679V	
	Control Circuit Power Supply		DC24V	
	Encoder Feedback		19BIT/23BIT Communication Encoder	
	Control Method		PWM Control, Sinusoidal Current Drive Method	
	Operating Environment	Ambient Temperature		Operation: -10°C to 40°C (non-condensing) / Storage: -20°C to 60°C (non-condensing)
		Ambient Humidity		Operation/Storage: Below 90% RH (non-condensing)
		Vibration/Shock Resistance		4.9m/s <sup>2</sup> /19.6m/s <sup>2</sup>
	Functions	Protection Functions		Overvoltage, Undervoltage, Overheating, Overcurrent, Overload, Overspeed, Excessive Position Deviation, Output Short Circuit, Encoder Error, Overtravel Protection, Oscillation Protection, etc
		STO		Standard Configuration
Communication Interface			USB Type-C, RS-485, EtherCAT	
Position output	Dividing function		Has	
	Open-collector 2-phase output		Has	
Analog Input			None	
Input/ Output Signals	Digital Input(SI)		6 channels Servo Enable, Alarm Reset, Forward Prohibit, Reverse Prohibit, Torque Limit Selection, Internal Speed Selection, Mode Switching, Pulse Input Prohibit, Zero Speed Lock, Position Error Clear, Internal Position Step Signal, Internal Control Mode Direction Switching	
	Digital Output(SO)		4 channels Positioning Complete, Servo Ready, Alarm Output, Torque Limit Output, Co-speed Detection, Rotation Detection, Speed Reached, Brake Release Output, Warning Output	
Position Control Model	Pulse Command Model		Not Supported	
	Control Method		Internal Position/ EtherCAT Motion Bus	
	Feedforward Compensation		0~100% (Setting Resolution: 1%)	
	Positioning Completion Width Setting		1~65535 command units (Setting Resolution: 1 command unit)	
Speed Control Model	Electronic Gear Ratio		1/65530 ≤ B/A < 65535	
	Control Method		Internal three-speed selection, External speed mode	
		Command Smoothing Method		Low-pass filter, Smoothing filter
	Analog Input	Voltage Range		None
		Input Impedance		None
	Torque Limiting		Internal Parameters External load variation (0~100% load): ±0.01% or less (at rated speed)	
Torque Control Model	Speed Fluctuation Rate		Rated voltage ±10%: 0.01% (at rated speed)	
			Ambient temperature 20±25°C: ±0.01% or less (at rated speed)	
	Control Method		Internal Torque	
Bus Control Model	Communication Protocol		EtherCAT Protocol	

Specifications		Model	Inverter Unit	
			<b>DM6-R Series</b>	
Basic Specifications	Power Range(KW)		22KW, 45KW, 75KW, 110KW, 160KW	
	Input Power		THREE-PHASE AC380V-440V, 50HZ/60HZ	
	Control Circuit Power		DC24V	
	Control Method		Three-phase full-wave rectification IPM, PWM control, sinusoidal current drive method	
	Operating Environment	Ambient Temperature		Operation: -10°C to 40°C (no condensation) / Storage: -20°C to 60°C (no condensation)
		Ambient Humidity		Operation/Storage: Below 90% RH (no condensation)
		Vibration/Shock Resistance		4.9M/S <sup>2</sup> /19.6M/S <sup>2</sup>
	Protection Functions		Overvoltage, undervoltage, overheating, oscillation protection, phase loss protection, etc.	

# Port Distribution

## 01 DM6-4110P0-R Rectifier Unit Terminal Layout

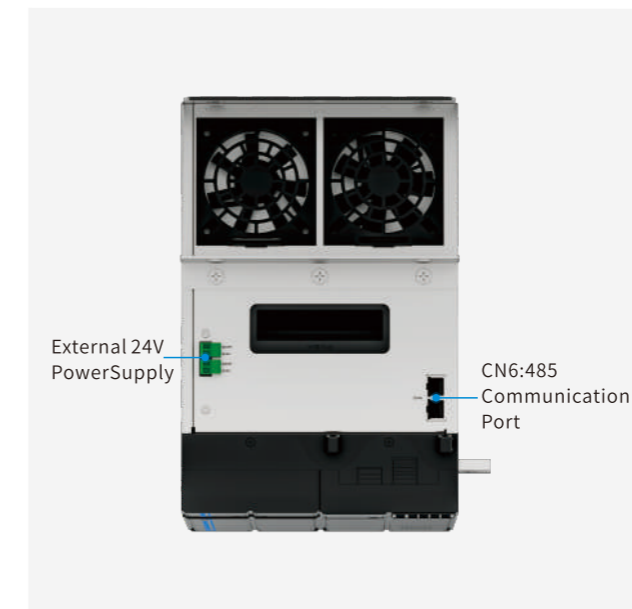

## 02 DM6C 15kW/7.5kW/5.5KW/3kW/1.5kW/750W/400W Inverter Module Front Terminal Layout

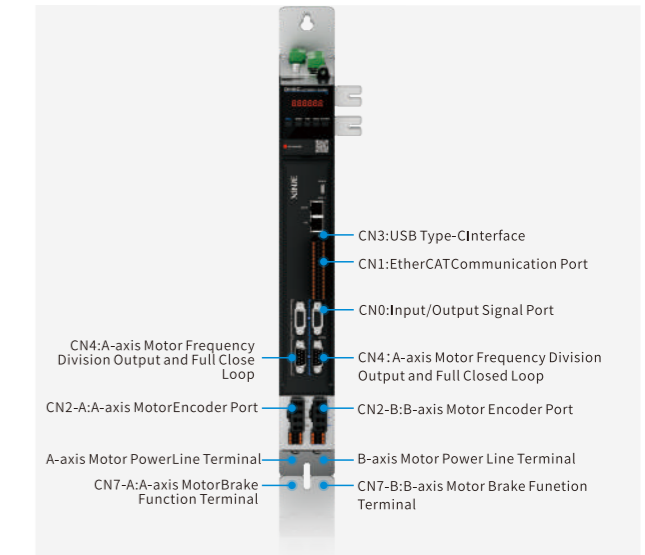

## 03 DM6C 15kW/7.5kW/5.5KW/3kW/1.5kW/750W/400W Inverter Module Top View Terminal Layout

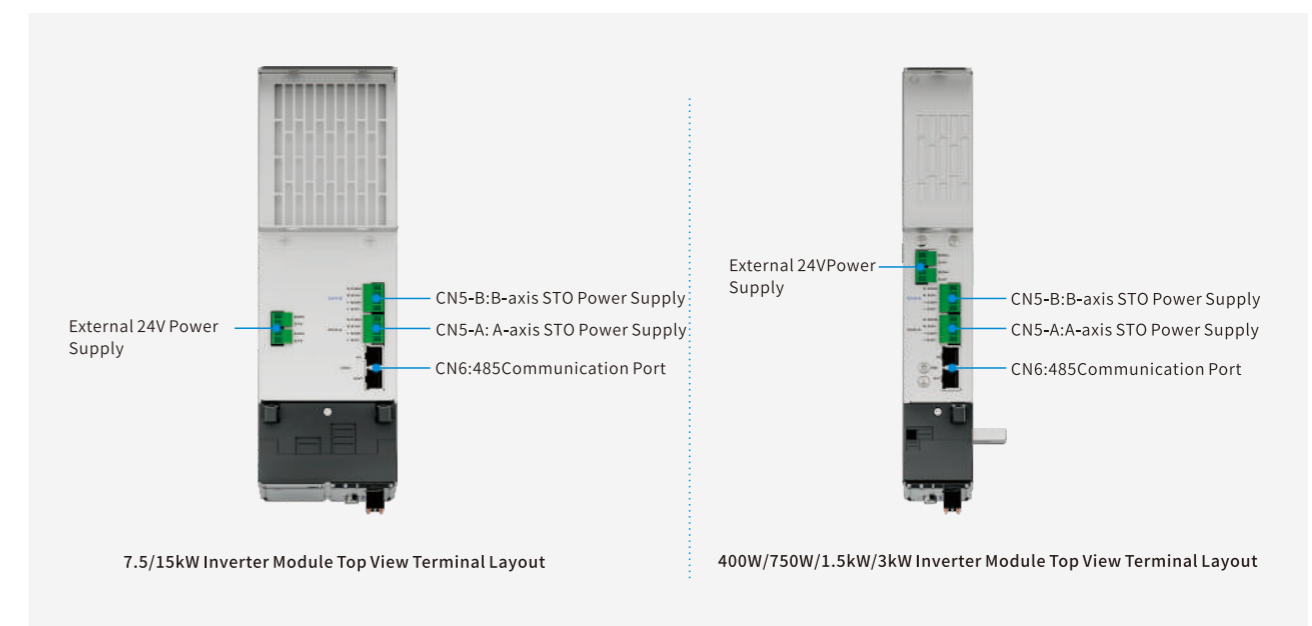

# Installation Dimensions

(unit:mm)

## 01 Rectifier Unit

DM6-4110P0-R

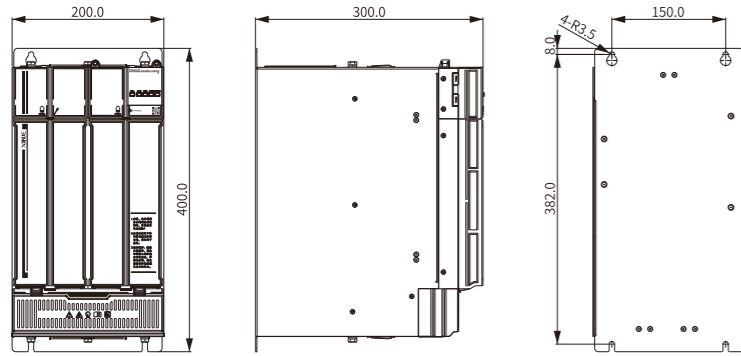

## 02 Inverter Unit

DM6C-40P4/40P7/41P5/43P0-M

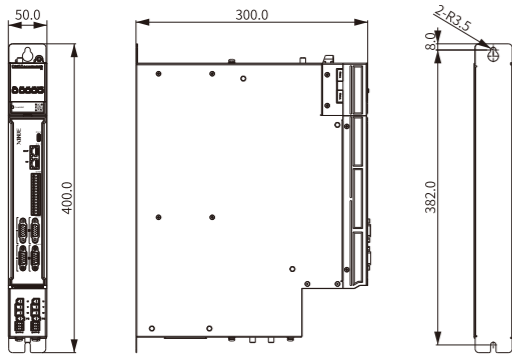

DM6C-45P5/47P5/415P0-M

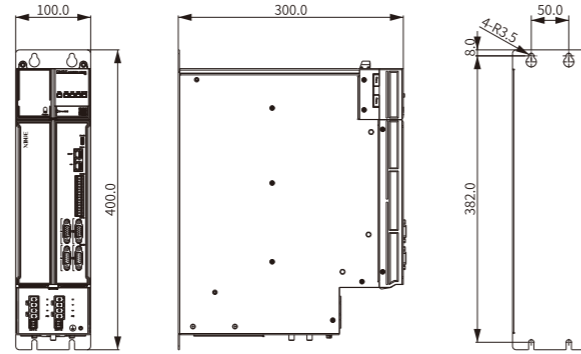

DM6C-455P0S/475P0S-M

