

# Compact 8-Port Giga Smart Ethernet Din-rail Switch

## IDS408GS

### 8 Port Giga Smart Ethernet Din-rail Switch

The IDS408GS is engineered with a rugged mechanical design and compact form factor, making it ideal for installation in space-constrained industrial cabinets. Its IP40 ingress protection ensures durability in harsh environments, while a wide operating temperature range of -25°C to 75°C enables reliable performance in extreme conditions. Smart network features including VLAN, QoS, IGMP, DHCP client, RSTP, and web/SNMP management. The switch also features enhanced protection mechanisms, including  $\pm 15\text{KV}$  air and  $\pm 8\text{KV}$  contact ESD protection. With a DC 12V–58V power input and built-in reverse polarity protection, the IDS408GS delivers stable and secure operation for demanding industrial applications.



### Features & Benefits

#### Full Gigabit Switching

- 8-port Full-Giga Ethernet with Auto Negotiation
- 16K MAC address table
- Stores and forwards with non-blocking switch fabric
- Switching capacity: **16Gbps** for layer 2 application
- Packet Buffer: 1.5M
- Forwarding Latency: <5us
- Jumbo Frame: 10Kbytes
- Overall packet forwarding rate: **11.9Mpps**

#### Rugged Mechanical Design

- Robust design protects from mechanical deformation
- IP40 ingress protection to withstand harsh environment
- Wide operating temperature range -25 ~ 75°C
- Anti-static (ESD) air  $\pm 15\text{KV}$  contact  $\pm 8\text{KV}$
- Power input DC 12V-58V provides reverse connection protection

#### Smart Ethernet Management

- DHCP Client, Flow Control, Port Statistics, IGMP snooping, VLAN, QoS
- Port Mirror 1:1 / N:1
- SNMP, Web Management
- STP/RSTP network redundancy
- Firmware upgrade / Configuration upload / download



## Interfaces

### IDS408GS

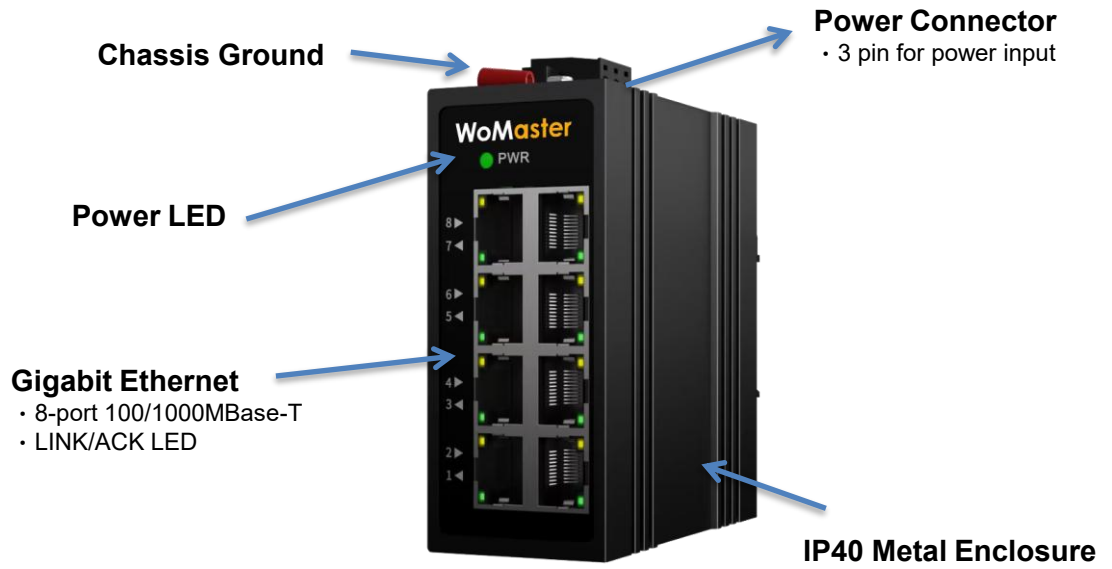

## Dimensions

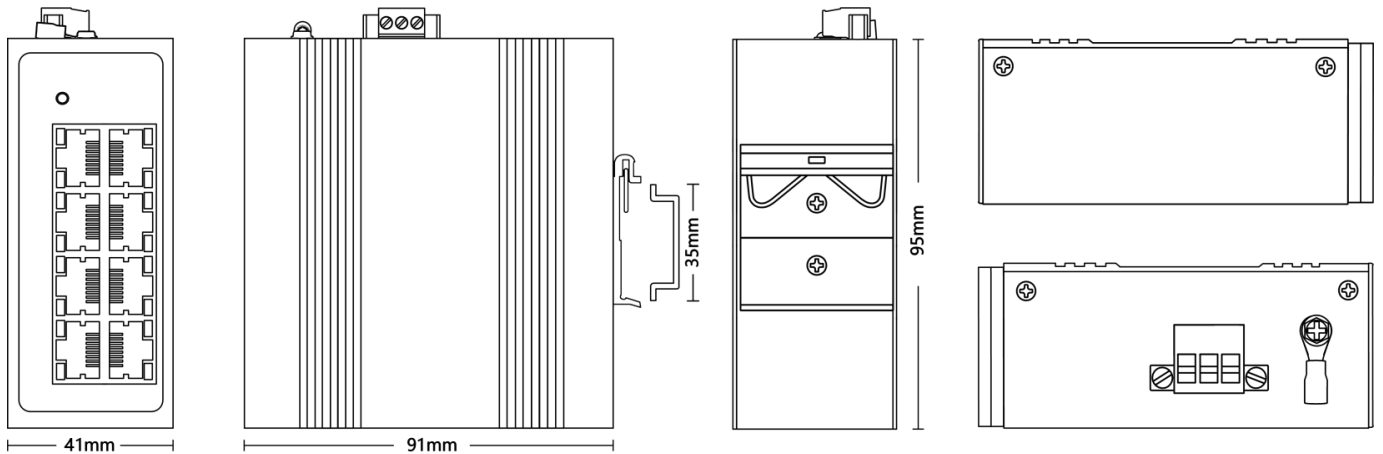

Technology	
Standard	IEEE 802.3 10Base-T Ethernet
	IEEE 802.3u 100Base-TX Fast Ethernet
	IEEE 802.3 Flow control
	IEEE 802.3z 1000Base-X
	IEEE 802.3ab 1000Base-T Gigabit Ethernet Copper
Performance	
Switch Technology	Store and Forward Technology with Non-Blocking Switch Fabric
Number of MAC Address	16K
Packet Buffer Memory	1.5M bits
Switching capacity	16Gbps application level: layer 2
Overall packet forwarding rate	11.9Mpps
Interface	
Ethernet Port	8 x 10/100/1000Base-TX RJ45, Auto Negotiation
System LED	1 x Power: Red On
Ethernet Port LED	Link (Yellow On), Activity (Yellow Blinking)
Power input	3-Pin Removable Terminal Connector
Power Requirement	
Input Voltage	DC12V-58V
Reverse Polarity Protect	Yes
Power Consumption	store forward power consumption: < 10W
Software	
L2 Network	DHCP Client, Flow Control, Port Statistics, IGMP snooping, VLAN, QoS Port Mirror 1:1 / N:1
Management	SNMP, Web, Firmware upgrade, Configuration upload/download
Redundancy	STP, RSTP
Mechanical	
Installation	DIN Rail
Enclosure Material	Aluminum alloy metal
Dimension	91 (D) x 95(H) x 41mm (W)
Ingress Protection	IP40
Weight	~370g without package
Environmental	
Operating Temperature & Humidity	-25°C~75°C , 5%~95% Non-Condensing
Storage Temperature	-40°C~85°C
MTBF	100,000 hours
Warranty	5 Years
Surge Protection	IEC 61000-4-5 Level X (4KV/2KV) (8/20us) Power IEC 61000-4-5 Level 4(4KV/2KV) (10/700us)
ESD	IEC 61000-4-2 Level 4 (8K/15K)

 Ordering Information

Model Name	Description
IDS408GS	Din-rail 8-Port Smart Giga Ethernet Switch
	Package List
	1 x Product Unit with Din Clip
	1 x 3-pin Removable Terminal Connector
	1 x Quick Installation Guide