

# GC-4642

2-channel analog output module(0mA~20mA)

User manual

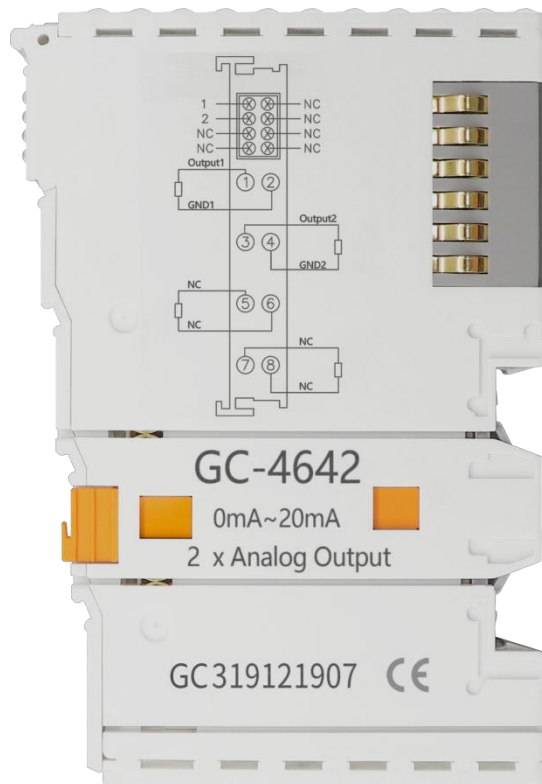

Document version: V3.01 (2020/12/21)

## Contents

1. Function Introduction .....	4
1.1 Functional Overview .....	4
1.2 Performance characteristics .....	4
1.2 Typical applications .....	4
2. Equipment installation and use .....	5
2.1 Module fixing .....	5
2.2 Wiringmethod .....	5
2.3 System status indicator .....	7
2.4 Use in combination with PLC400/510 series .....	7
2.5 Combination with GCAN-IO-8000 series equipment .....	8
3. Technical specifications .....	9
4. Disclaimer .....	10
5. Module selection table .....	11
Sales and service .....	13

# 1. Function Introduction

## 1.1 Functional Overview

GC-4642 (2-channel analog output module, 0-20mA) can be used to output signals in the range of 0-20mA. This terminal module can provide electrical isolation signals with a resolution of 16 bits for the processing layer. The GC-4642 module has 2 two-wire output terminals, which are especially suitable for installation in a control cabinet to save space. The GC-4642 module has a common ground potential terminal, and the power contacts are connected together. The reference ground of the output terminal is the 0V power contact.

## 1.2 Performance characteristics

- The number of output points is 2;
- The signal voltage is 0mA~20mA;
- Powered by external 24V;
- The load is greater than 5k $\Omega$  (short circuit protection);
- Measurement error is less than  $\pm 0.1\%$  (full scale) ;
- The measurement resolution is 16 bits;
- Conversion time is about 4ms;
- The electrical isolation is 1500 Vrms;
- The current consumption is about 150mA;
- The bit width output in the process image is 2x 2 bytes;
- Configuration without address setting, through bus coupler or controller configuration;
- Applicable to all GSCAN-PLC-400 series and GSCAN-8000 series bus terminal modules;
- Working temperature range: -40 $^{\circ}\text{C}$ ~+85 $^{\circ}\text{C}$ ;
- Dimensions: length 100mm \* width 69mm \* height 12mm.

## 1.2 Typical applications

- Standard analog signals can be output externally according to instructions;
- It can be used to adjust the opening of control equipment such as valves and gates;
- Connect to the bus coupler or controller to realize the transmission of analog signals.

## 2. Equipment installation and use

This chapter will explain in detail the installation method, wiring method, the meaning of the indicator light and the meaning of the interface of GC-4642 module.

### 2.1 Module fixing

The installation method of the GC-4642 module is shown in Figure 2.1. You need to use a flat-blade screwdriver for auxiliary installation.

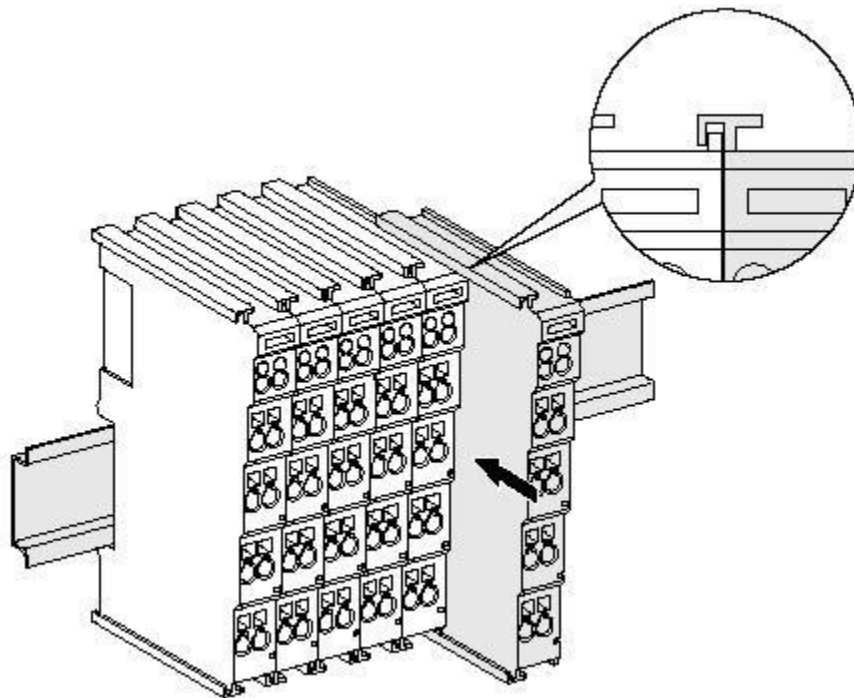

Figure 2.1 GC-4642 module installation

First, you need to install the fieldbus coupler on the rail, and then attach the GC-4642 module to the right of the fieldbus coupler or other modules to add this component. As shown in Figure 2.1, insert the GC-4642 module inwards along the slot until the latch snaps.

The GC-4642 module is powered by GC-bus, no additional power supply is required. You only need to connect the power supply to the bus coupler and connect the GC-4642 to the module composed of the bus coupler to realize the power supply of the GC-4642.

### 2.2 Wiringmethod

As shown in Figure 2.2, use a flat-blade screwdriver to insert it into the square hole and hold the screw in the square hole. Then insert the cable into the circular hole. After plugging in, pull out the screwdriver, and the cable can be

firmly locked in the circular hole.

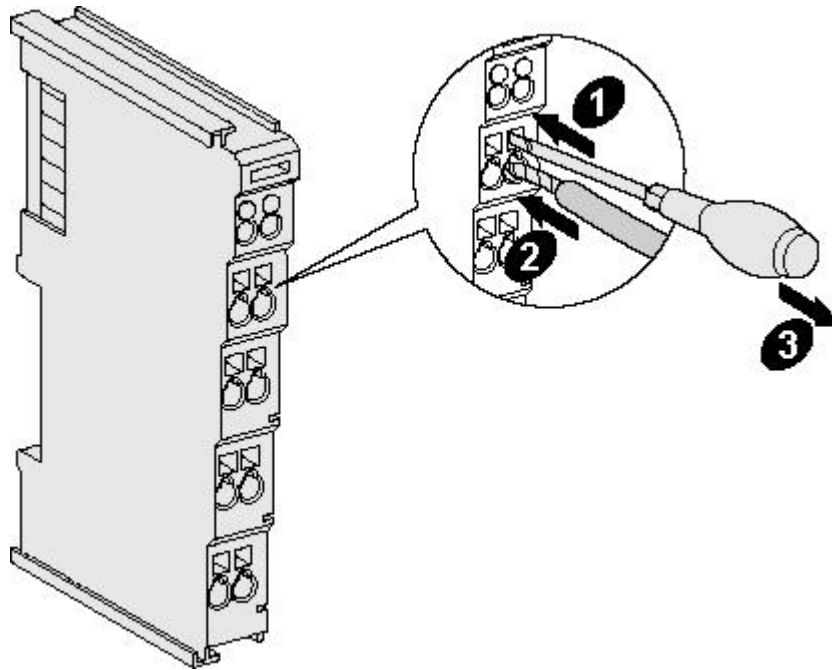

Figure 2.2 GC-4642 module installation

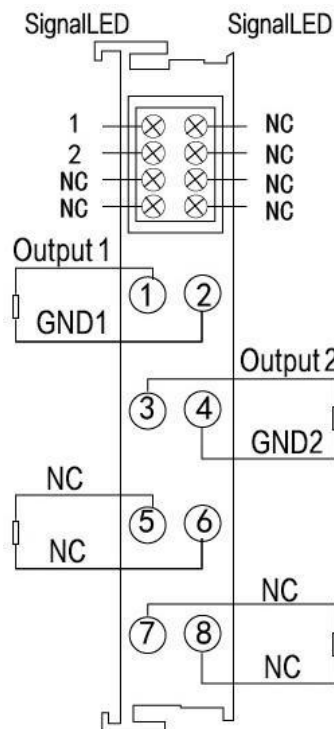

Figure 2.3 GC-4642 module terminal block

The terminal block of GC-4642 module is shown in Figure 2.3. GC-4642 contains 2 sets of output points, and can connect up to 2 sets of analog signals. The serial numbers corresponding to the terminals and their meanings are shown in Table 2.1.

Terminal	Serial number	meaning
Output1	1	Group 1 signal voltage output
GND1	2	Group 1 signal reference ground
Output2	3	Group 2 signal voltage output
GND2	4	Group 2 signal reference ground

Table 2.1 GC-4642 module indicator

## 2.3 System status indicator

The GC-4642 module has 4 operating indicators to indicate the operating status of the device. The specific indication function of the indicator light is shown in Table 2.2. When the indicator is on, the GC-4642 module status is shown in Table 2.3.

Indicator light	Colour	Indication status
RUN	green	Operating instructions

Table 2.2 GC-4642 module indicator

When the output signal of the GC-4642 module is activated, the operation indicator will light up.

Indicator light	Status	Indication status
RUN	Always on	Output signal activation
	not bright	Output signal is not activated

Table 2.3 GC-4642 module indicator status

## 2.4 Use in combination with PLC400/510 series

GSCAN-PLC-400/510 supports programming in five languages. The following takes ST language as an example to introduce how to use GSCAN-PLC-400 to program and write the status of the analog output of the GC-4642 module.

When the GC-4642 module performs ST programming definition, it is necessary to define the variable type, output signal position, start character, separator, etc. For example: "AO AT%Q0.0:INT;", where "0.0" represents the start address of the first channel, each channel occupies 2 bytes, 0~20mA corresponds to 0~65535, so the start address of the second channel The starting address is Q2.0. When the user uses more than one GC-4642 module, the second GC-4642 needs to be defined from "Q4.0", because each 4642 has 2 channels; "%" (percent sign) is the direct variable start symbol : ";" (semicolon) is a variable or type separator. Use symbolic variable AO to write unsigned

integer from %Q0.0 address. AT stands for the address of variable access and the additional attributes of the variable (see page 46 of the e-book for details). (Note: Input only affects input, output only affects output, output and input do not affect each other. That is, if there is and only an input module in front of the output module, then no matter how many input modules are in front, the address of the first output module is still Q0 .0.)

## **2.5 Combination with GSCAN-IO-8000 series equipment**

The status of the analog output is represented by two bytes. For example: GSCAN-IO-8000 module node number is 1, if you want channel 1 of the first GC-4642 module to output 10mA, and other channels output 0mA, you need to write CAN data to GSCAN-IO-8000 module The frame ID is 0x201, the data length (DLC) is 8, and the frame data is 0xFF, 0x7F, 0x00, 0x00, 0x00, 0x00, 0x00, 0x00 data.

### 3. Technical specifications

<b>Interface characteristics</b>	
Output points	2
Signal voltage	0mA~20mA
load	> 5k $\Omega$ (Short circuit protection)
power supply	Powered by external 24V
Resolution	16 bits
Conversion time	4ms
Measurement error	< $\pm 0.1\%$ (full scale)
ESD rating	7 kV
Electrical isolation	2500 Vrms
Current consumption	150mA
Bit width in process image	Output: 2 x2 bytes
configuration	No address setting, configuration via bus coupler or controller
Pluggable wiring	Suitable for all GCFAN-PLC-400 series, GCFAN-8000 series bus terminal modules
<b>Environmental test</b>	
Operating temperature	-40 $^{\circ}$ C~+85 $^{\circ}$ C
Working humidity	95%RH, no condensation
EMC test	EN 55024:2011-09 EN 55022:2011-12
Anti-vibration/impact resistance	EN 60068-2-6/EN 60068-2-27/29
Anti-electromagnetic interference/anti-electromagnetic radiation performance	EN 61000-6-2 /EN 61000-6-4
Protection class	IP 20
<b>Basic Information</b>	
Dimensions	100mm *69mm *12mm
weight	50g



## 4. Disclaimer

Thank you for purchasing GCAN's GCAN series of hardware and software products. GCAN is a registered trademark of Shenyang Vhandy Technology Co., Ltd. This product and manual are copyrighted by Vhandy Technology. Without permission, it is not allowed to reproduce in any form. Before using, please read this statement carefully. Once used, it is deemed to be an endorsement and acceptance of the entire content of this statement. Please strictly abide by the manual, product description and related laws, regulations, policies and guidelines to install and use the product. In the process of using the product, the user promises to be responsible for his actions and all consequences arising therefrom. Vhandy Technology will not be liable for any losses caused by improper use, installation, or modification by users.

The final interpretation right of the disclaimer belongs to Vhandy Technology

## 5. Module selection table

GSCAN-PLC-400 series products consist of a programmable main control module, several GC series IO modules and a terminal resistance module.

GC series IO modules currently include five categories: digital input, digital output, analog input, analog output, and communication extension. The specific selection table is shown in Table 5.1.

I/O	Type	Characteristic	Signal	Channel
PLC Control module	GSCAN-PLC-400	CPU:168M	-	-
	GSCAN-PLC-510	CPU:400M	-	-
	GSCAN-PLC-511	CPU:400M (2CAN)	-	-
Digital input	GC-1008	Digital input (PNP)	24V DC	8-channel
	GC-1018	Digital input (NPN)	24V DC	8-channel
	GC-1502	Counter (200kHz max)	-	2-channel
Digital output	GC-2008	Digital output (PNP)	24V DC	8-channel
	GC-2018	Digital output (NPN)	24V DC	8-channel
	GC-2204	relay output	-	4-channel
	GC-2302	PWM (20Hz~200kHz)	-	2-channel
Analog input	GC-3604	Voltage input, 16 bits	-5~+5V	4-channel
	GC-3624	Voltage input, 16 bits	10V~+10V	4-channel
	GC-3644	Current input, 16 bits	0-20mA	4-channel
	GC-3654	Current input, 16 bits	4-20mA	4-channel
	GC-3664	Voltage input, 16 bits	0~+5V	4-channel
	GC-3674	Voltage input, 16 bits	0~+10V	4-channel
	GC-3804	2-wire PT100, 16 bits	Thermal resistance	4-channel
	GC-3822	3-wire PT100, 16 bits	Thermal resistance	2-channel

	GC-3844/3854/3 864	K type / S type / T type thermocouple	Thermocouple	4-channel
Analog output	GC-4602	Voltage output, 16 bits	-5V~+5V	2-channel
	GC-4622	Voltage output, 16 bits	-10V~+10V	2-channel
	GC-4642	Current output, 16 bits	0-20mA	2-channel
	GC-4652	Current output, 16 bits	4-20mA	2-channel
	GC-4662	Voltage output, 16 bits	0~5V	2-channel
	GC-4672	Voltage output, 16 bits	0~10V	2-channel
	GC-4674	Voltage output, 12 bits	0~10V	4-channel
Special module	GC-6101	RS232/RS485 extension	-	-
	GC-6201	GPRS extension	-	-
	GC-6221	4G extension	-	-
	GC-6501	WiFi extension	-	-

Table 5.1 Selection table

## Sales and service



Shenyang Vhandy Technology Co., Ltd.

**Address:** No.135-21, Changqing Street, Hunnan, Shenyang, Liaoning, China.

**E-mail:** [sygckj@gmail.com](mailto:sygckj@gmail.com)

**Tel/ Whatsapp:** +86 13644001762

**Skype:** live:sygckj

**WeChat:** gckj777

**Website:** [gcanbus.com](http://gcanbus.com)