

GC-3822

2-channel PT100 input module (RTD)

User manual

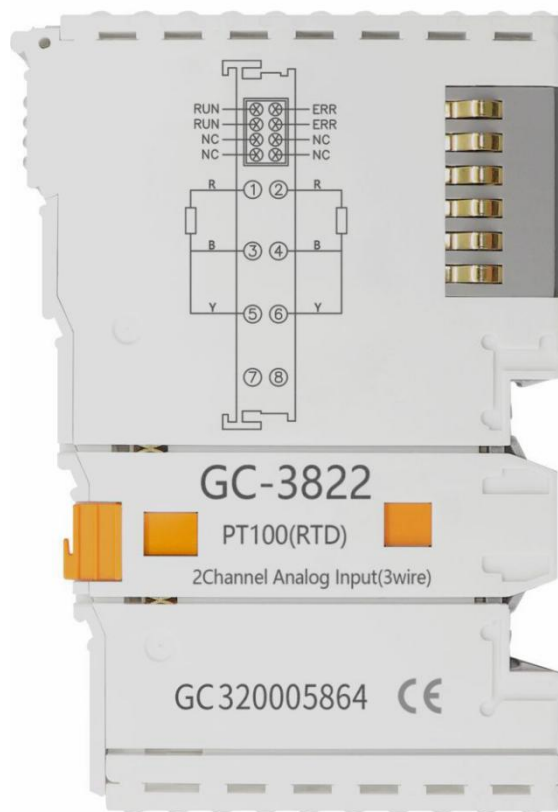

Document version: V3.01 (2017/10/22)

Contents

1. Function introduction	4
1.1 Functional Overview	4
1.2 Performance characteristics	4
1.3 Typical application	4
2. Equipment installation and use	5
2.1 Module fixing	5
2.2 Wiring method	5
2.3 System status indicator	7
2.4 Use in combination with GCAN-PLC-400/510 series	7
2.5 Combination with GCAN-IO-8000 series equipment	8
3. Technical specifications	9
4. Disclaimer	10
5. Module selection table	11
Sales and service	13

1. Function introduction

1.1 Functional Overview

The GC-3822 module is an I/O module with integrated 2 temperature sensor (PT100) input channels. The module can be used to collect temperature information in real time and send the collected values to the GSCAN-PLC-400/510 series controller or GSCAN-8000/8100 series coupler via the internal bus. This module can be used with any other GC series IO module to realize the collection and processing of temperature analog data in industrial automation or distributed control systems.

1.2 Performance characteristics

- The number of input points is 2;
- The wiring form adopts 3-wire system;
- The sensor type is PT100;
- The measuring temperature range is -200~+500°C;
- The measurement resolution is 0.1°C/digit;
- Conversion time is about 250ms;
- Measuring current flow is less than 0.5 mA (depending on load);
- The electrical isolation is 500Vrms;
- Power supply via GSCAN-PLC-400 or GSCAN-8000/8100;
- Current consumption is 200mA;
- The bit width input in the process image is 2 x 2bytes;
- Configuration without address setting, through bus coupler or controller configuration;
- Working temperature range: -40°C~+85°C;
- Dimensions: length 100mm * width 69mm * height 12mm.

1.3 Typical application

- Directly connect the resistance sensor;
- Connect the PT100 to the bus coupler or controller.

2. Equipment installation and use

This chapter will explain in detail the installation method, wiring method, the meaning of indicator light and the meaning of interface of GC-3822 module.

2.1 Module fixing

The installation method of the GC-3822 module is shown in Figure 2.1. You need to use a flat-blade screwdriver for auxiliary installation.

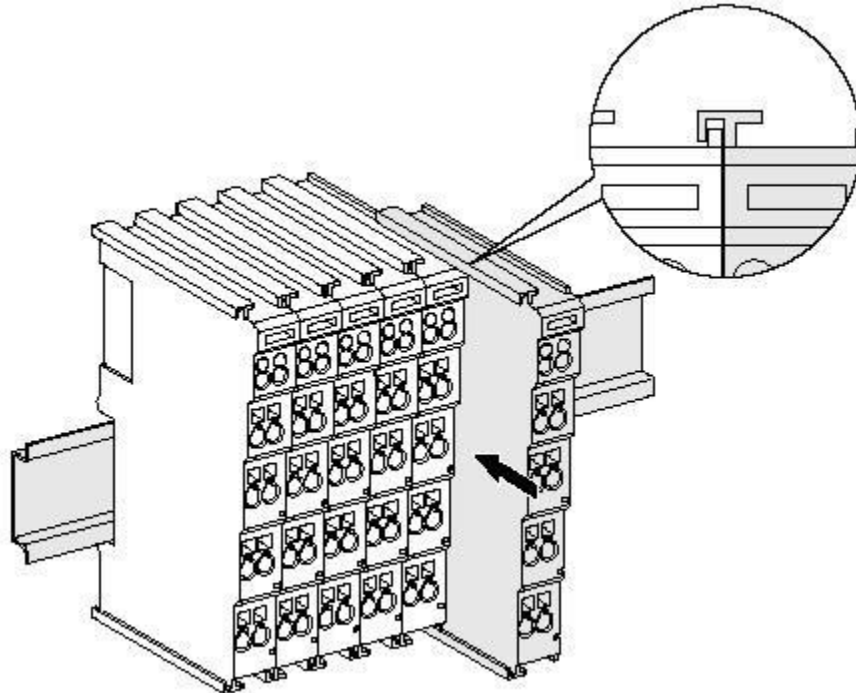

Figure 2.1 GC-3822 module installation

First, you need to install the fieldbus coupler on the rail, and then attach the GC-3822 module to the right of the fieldbus coupler or other modules to add this component. As shown in Figure 2.1, insert the GC-3822 module inwards along the slot until the latch snaps and makes a “click” sound.

The GC-3822 module needs to be used with the GCFAN-PLC-400/510 series controller or the GCFAN-8000/8100 series coupler, and can be directly powered by the coupler, so there is no need to separately provide additional power to it.

2.2 Wiring method

As shown in Figure 2.2, first use a flat-blade screwdriver to insert into the square hole and press the screw in the square hole. Then insert the cable into the circular hole. After plugging in, pull out the screwdriver, and the cable can be firmly locked in the circular hole.

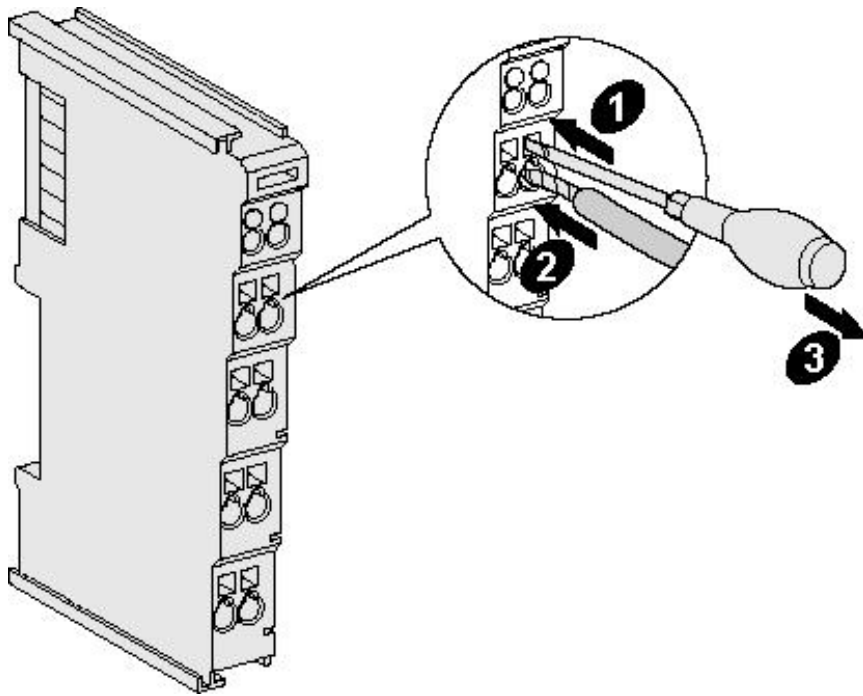

Figure 2.2 GC-3822 module installation

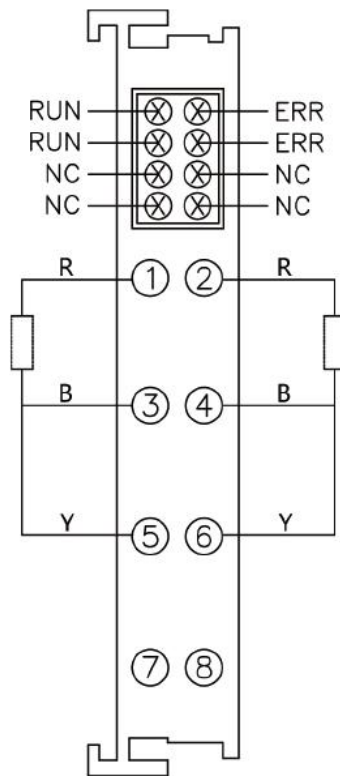

Figure 2.3 GC-3822 module terminal block

The terminal block of GC-3822 module is shown in Figure 2.3. The GC-3822 contains 2 sets of inputs and can connect up to 2 PT100 sensors. The serial numbers corresponding to the terminals and their meanings are shown in Table2.1.

Serial number	Meaning
1	The first R (red signal line) input
2	The second R (red signal line) input
3	The first B (blue signal line) input
4	The second B (blue signal line) input
5	The first Y (yellow signal line) input
6	The second Y (yellow signal line) input
7	No input
8	No input

Table 2.1 GC-3822 module wiring

2.3 System status indicator

The GC-3822 module has 2 red error indicators 2 and 4 and 2 green operation indicators 1 and 3 to indicate the operating status of the device. The specific indication function of the indicator light is shown in Table 2.2. When the indicator is on, the GC-3822 module status is shown in Table 2.3.

Indicator light	colour	Indication status
ERROR	red	Error indication
RUN	green	Operating instructions

Table 2.2 GC-3822 module indicator

After the GC-3822 module is connected to the PT100 normally, the operation indicator will light up.

Indicator light	Status	Indication status
ERROR	Red light always on	No temperature sensor access
	not bright	No error
RUN	Always on	Connect correctly
	not bright	No temperature sensor access

Table 2.3 GC-3822 module indicator status

2.4 Use in combination with GCAN-PLC-400/510 series

GCAN-PLC-400/510 supports programming in five languages. The following uses ST language as an example to introduce how to use GCAN-PLC-400 to program to read the status of the analog input of the GC-3822 module.

When the GC-3822 module performs ST programming definition, it is necessary to define the variable type, input signal position, start character, separator, etc. For example: "AI0 AT%I0.0:INT;", where "0.0" represents the

start address of the first channel, each channel occupies 2 bytes, the collected temperature corresponds to -32768~+32767 so the second The starting address of the channel is I2.0. When the user uses more than one GC-3822 module, the second GC-3822 needs to be defined from "I4.0", because each 3822 has 2 channels; "%" (percent sign) is the direct variable start symbol : ":" (semicolon) is a variable or type separator. Use the symbol variable AI0 to read the signed integer from the %I0.0 address.AT stands for the address of variable access and the additional attributes of the variable (see page 46 of the e-book for details).

(Note: Input only affects input, output only affects output, output and input do not affect each other. That is, if there is and only output module in front of the input module, then no matter how many output modules there are in front, the address of the first input module is still I0 .0.)

2.5 Combination with GSCAN-IO-8000 series equipment

The state of the analog input is represented by two bytes.

For example: GSCAN-IO-8000 module node number is 1, the input status of channel 1 of the first GC-3822 module is 26 °C , and the input status of other channels is not connected to the sensor, then the GSCAN-IO-8000 module sends CAN data frame ID is 0x181, data length (DLC is 8, frame data is 0x04, 0x01, 0xFF, 0x7F, 0xFF, 0x7F, 0xFF, 0x7F

The following table lists a common AI state and its corresponding state data.

AI status								
Number of channels	1		2		3		4	
state	26°C		No sensor connected		No sensor connected		No sensor connected	
CAN bus data	04	01	FF	7F	FF	7F	FF	7F

3. Technical specifications

Connection method	
Wiring form	3-wire system
Interface characteristics	
Input points	2个
sensor type	PT100
temperature range	-200~+500℃
Resolution	0.1℃/digital
Conversion time	<250 ms
Conversion time	0.5 mA
Measurement error	<±2℃
Electrical isolation	500 Vrms (GC-bus/ Signal voltage)
Power supply	Powered by GCAN-PLC-400/510 or GCAN-8000/8100 coupler, consumes about 200mA
Bit width in process image	Input: 2x2 bytes
Configuration method	Automatic configuration in order
Environmental test	
Operating temperature	-40℃~+85℃
Working humidity	95%RH, No condensation
EMC test	EN 55024:2011-09 EN 55022:2011-12
Anti-vibration/impact resistance	EN 60068-2-6/EN 60068-2-27/29
Anti-electromagnetic interference/anti-electromagnetic radiation performance	EN 61000-6-2 /EN 61000-6-4
Protection level	IP 20
Basic Information	
Dimensions	100mm *69mm *12mm
weight	50g

4. Disclaimer

Thank you for purchasing GCAN's GCAN series of hardware and software products. GCAN is a registered trademark of Shenyang Vhandy Technology Co., Ltd. This product and manual are copyrighted by Vhandy Technology. Without permission, it is not allowed to reproduce in any form. Before using, please read this statement carefully. Once used, it is deemed to be an endorsement and acceptance of the entire content of this statement. Please strictly abide by the manual, product description and related laws, regulations, policies and guidelines to install and use the product. In the process of using the product, the user promises to be responsible for his actions and all consequences arising therefrom. Vhandy Technology will not be liable for any losses caused by improper use, installation, or modification by users.

The final interpretation right of the disclaimer belongs to Vhandy Technology

5. Module selection table

GCAN-PLC-400 series products consist of a programmable main control module, several GC series IO modules and a terminal resistance module.

GC series IO modules currently include five categories: digital input, digital output, analog input, analog output, and communication extension. The specific selection table is shown in Table 6.1.

I/O	Type	Characteristic	Signal	Channel
PLC Control module	GCAN-PLC-400	CPU:168M	-	-
	GCAN-PLC-510	CPU:400M	-	-
	GCAN-PLC-511	CPU:400M (2CAN)	-	-
Digital input	GC-1008	Digital input (PNP)	24V DC	8-channel
	GC-1018	Digital input (NPN)	24V DC	8-channel
	GC-1502	Counter (200kHz max)	-	2-channel
Digital output	GC-2008	Digital output (PNP)	24V DC	8-channel
	GC-2018	Digital output (NPN)	24V DC	8-channel
	GC-2204	relay output	-	4-channel
	GC-2302	PWM (20Hz~200kHz)	-	2-channel
Analog input	GC-3604	Voltage input, 16 bits	-5~+5V	4-channel
	GC-3624	Voltage input, 16 bits	10V~+10V	4-channel
	GC-3644	Current input, 16 bits	0-20mA	4-channel
	GC-3654	Current input, 16 bits	4-20mA	4-channel
	GC-3664	Voltage input, 16 bits	0~+5V	4-channel
	GC-3674	Voltage input, 16 bits	0~+10V	4-channel
	GC-3804	2-wire PT100, 16 bits	Thermal resistance	4-channel
	GC-3822	3-wire PT100, 16 bits	Thermal resistance	2-channel

	GC-3844/3854/3864	K type / S type / T type thermocouple	Thermocouple	4-channel
Analog output	GC-4602	Voltage output, 16 bits	-5V~+5V	2-channel
	GC-4622	Voltage output, 16 bits	-10V~+10V	2-channel
	GC-4642	Current output, 16 bits	0-20mA	2-channel
	GC-4652	Current output, 16 bits	4-20mA	2-channel
	GC-4662	Voltage output, 16 bits	0~5V	2-channel
	GC-4672	Voltage output, 16 bits	0~10V	2-channel
	GC-4674	Voltage output, 12 bits	0~10V	4-channel
Special module	GC-6101	RS232/RS485 extension	-	-
	GC-6201	GPRS extension	-	-
	GC-6221	4G extension	-	-
	GC-6501	WiFi extension	-	-

Table 5.1 Selection table

Sales and service



Shenyang Vhandy Technology Co., Ltd.

Address: No.135-21, Changqing Street, Hunnan, Shenyang, Liaoning, China.

E-mail: sygckj@gmail.com

Tel/ Whatsapp: +86 13644001762

Skype: live:sygckj

WeChat: gckj777

Website: gcanbus.com